

1 2 3 4 5 6 7 8

A

B

C

D

E

F

A

B

C

D

E

F

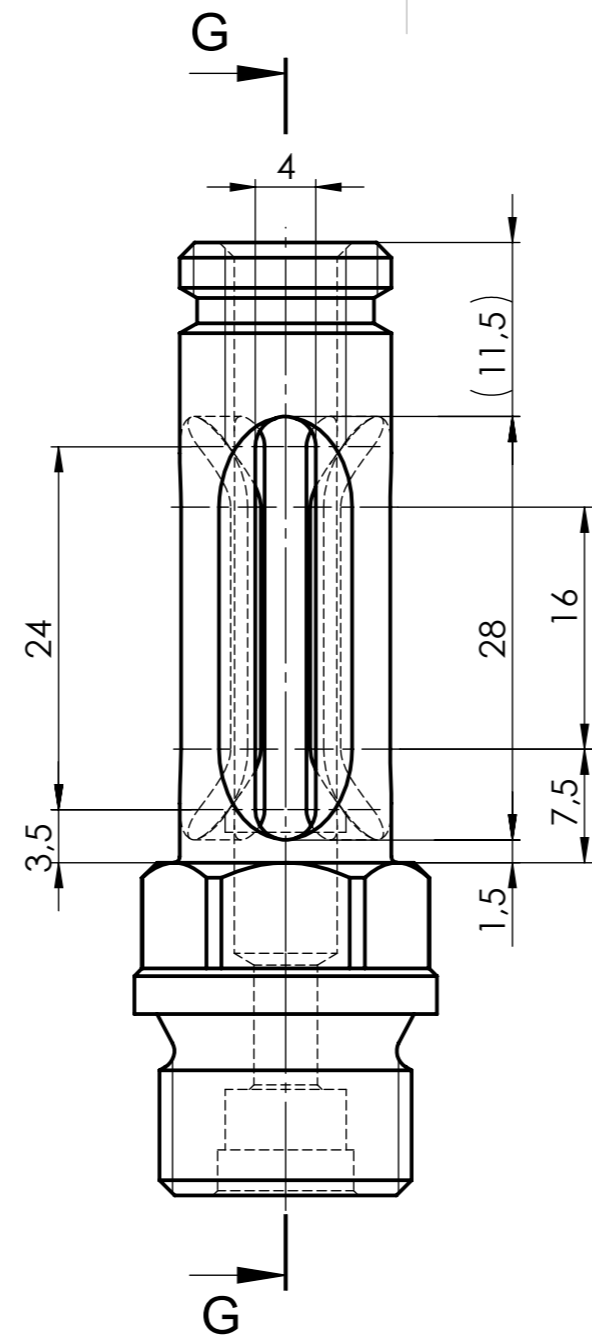
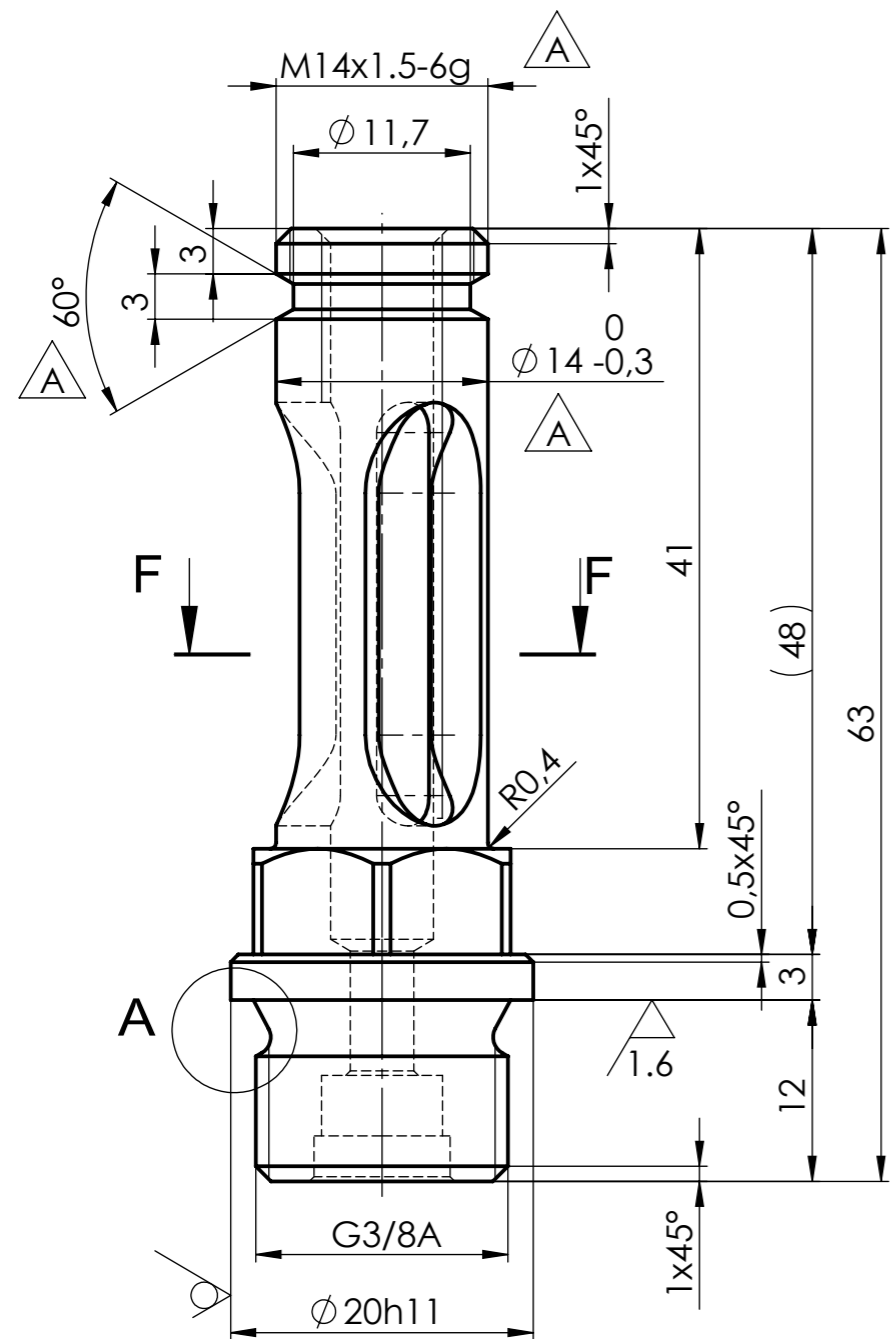

ŘEZ G-G

6 MIN PRO $\phi 8$
2,5 MIN PRO $\phi 9H8$

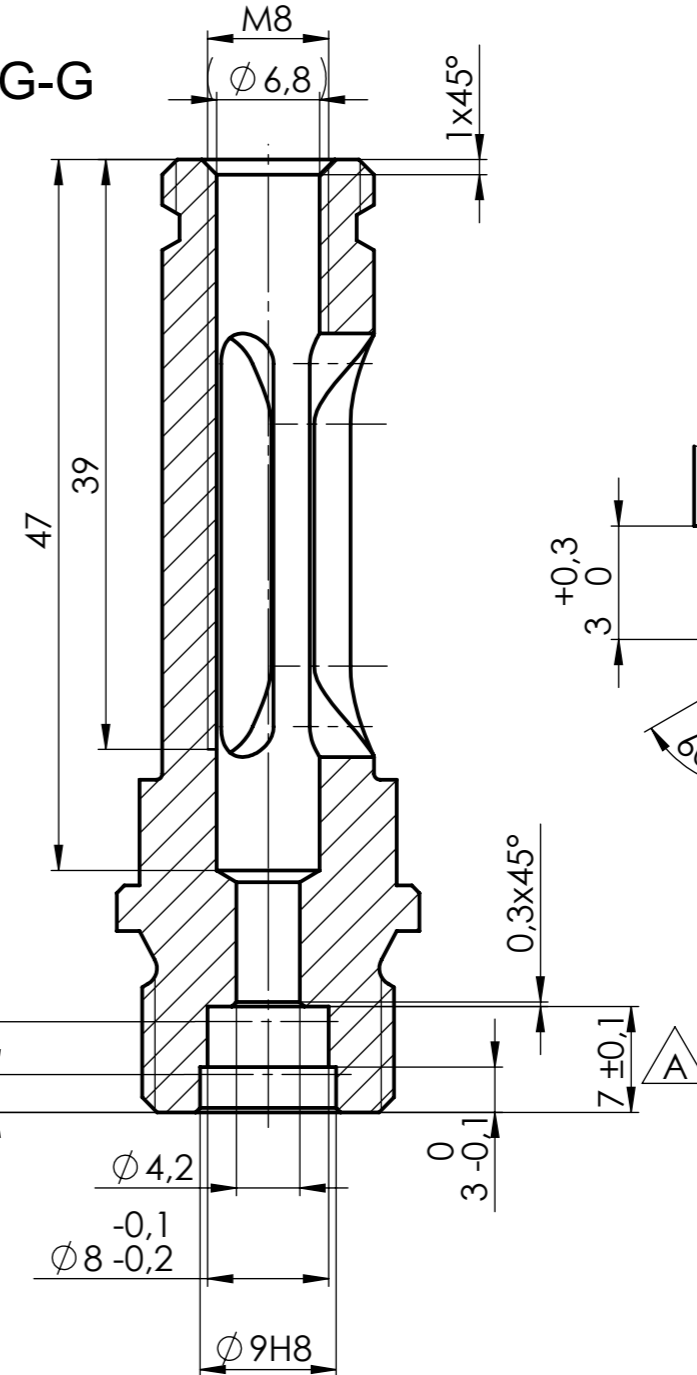

A
M 5:1

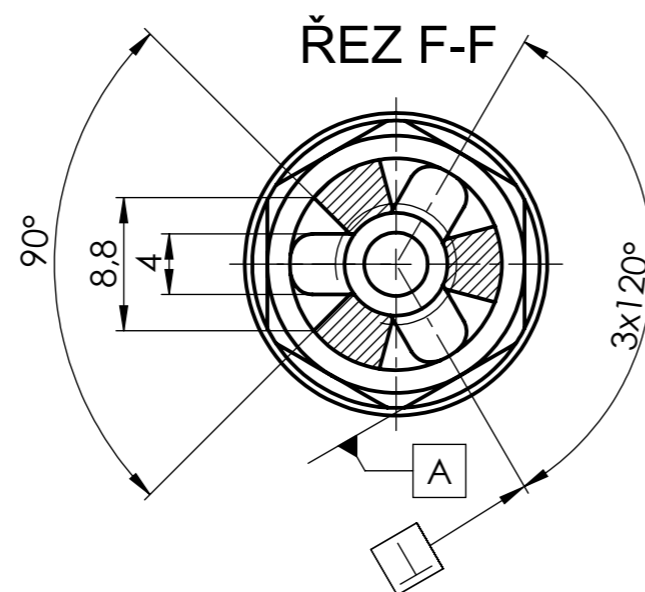
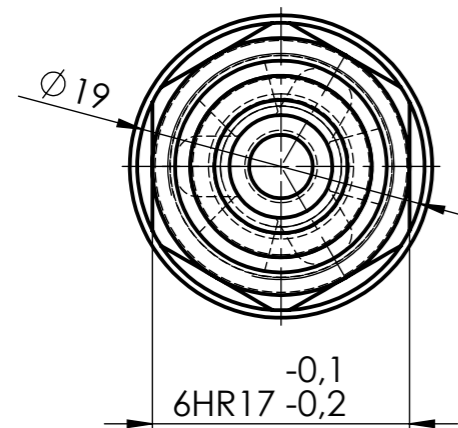
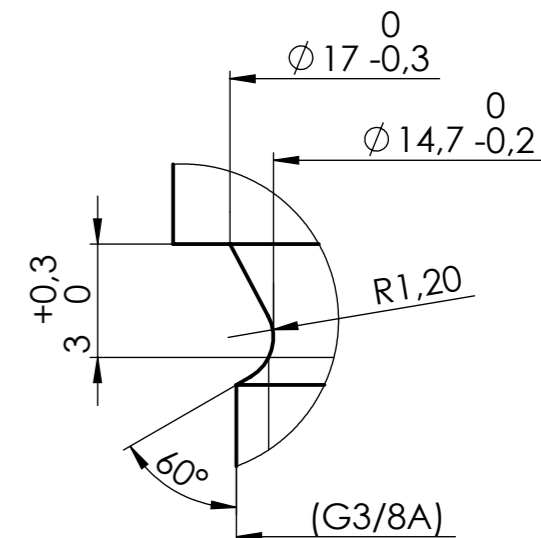

A	ZMĚNA TVARU		13.3.2015
ZMĚNA	POPIS ZMĚNY	ZMĚNU PROVEDL	DATUM ZMĚNY
ZMĚNOVÁ TABULKA			
Unmarked edges: 0,3x45°		Tolerance	ČSN ISO 8015
Carburizing depth:		Drawing precision	ČSN ISO 2768-mK
Hardened on:		Projection	2:1
Surface treatment: ISO 2081- Fe/Zn12/A			
Material	11SMn30+C (11 109)		
Dimension	KR 20-67		
Raw product	ČSN EN 10278		
TPD	ČSN EN 10277-3		
Mass netto	0.06 kg	Mass brutto	kg
PCM	155 121 109 077	Title	
List No.		Name	Date
File No.	Kreslil	Type	
Assembly No.	Technologist	Drawing No.	
Old drawing	Normalization	52 1072	
	Approved	Pos.	

1 2 3 4 5 6 7 8