

DETAIL A
SCALE 1 : 2

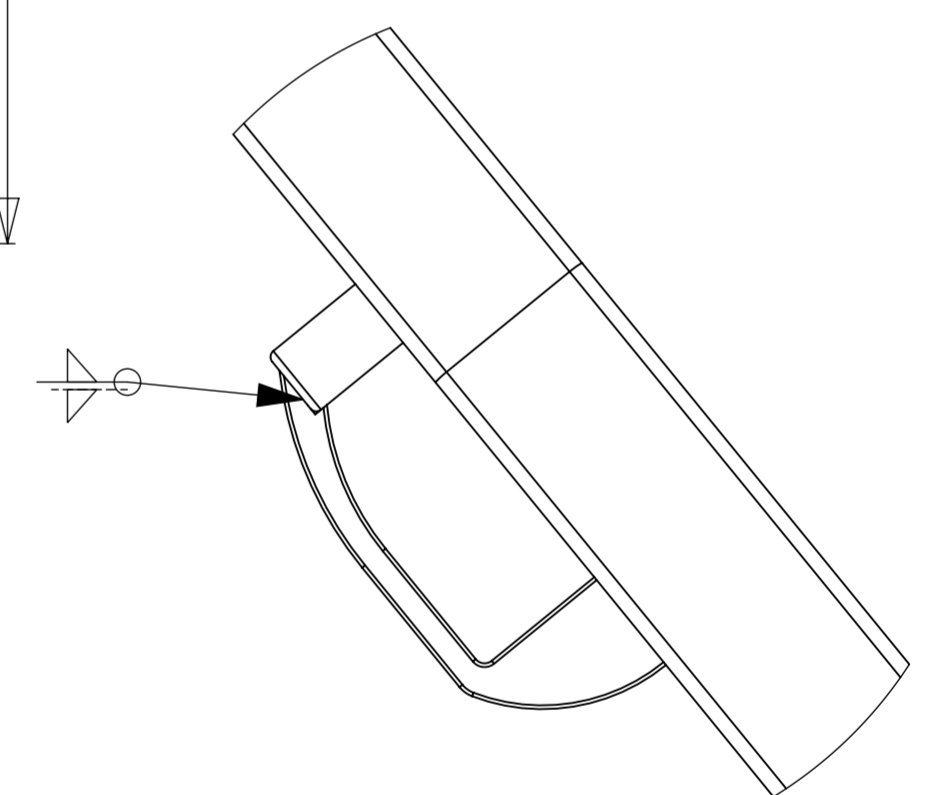

VIEW E
SCALE 1 : 2

FRAME

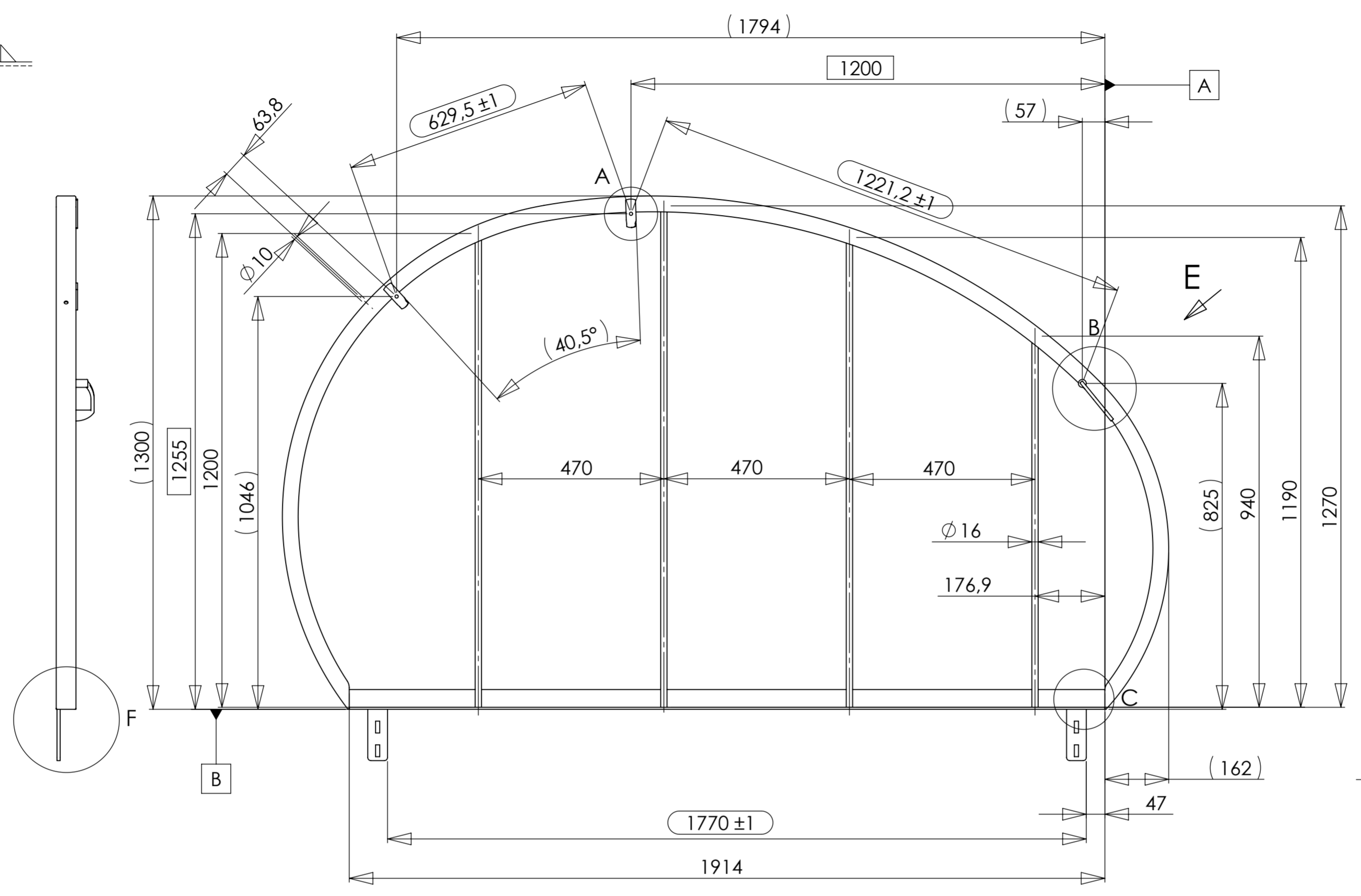
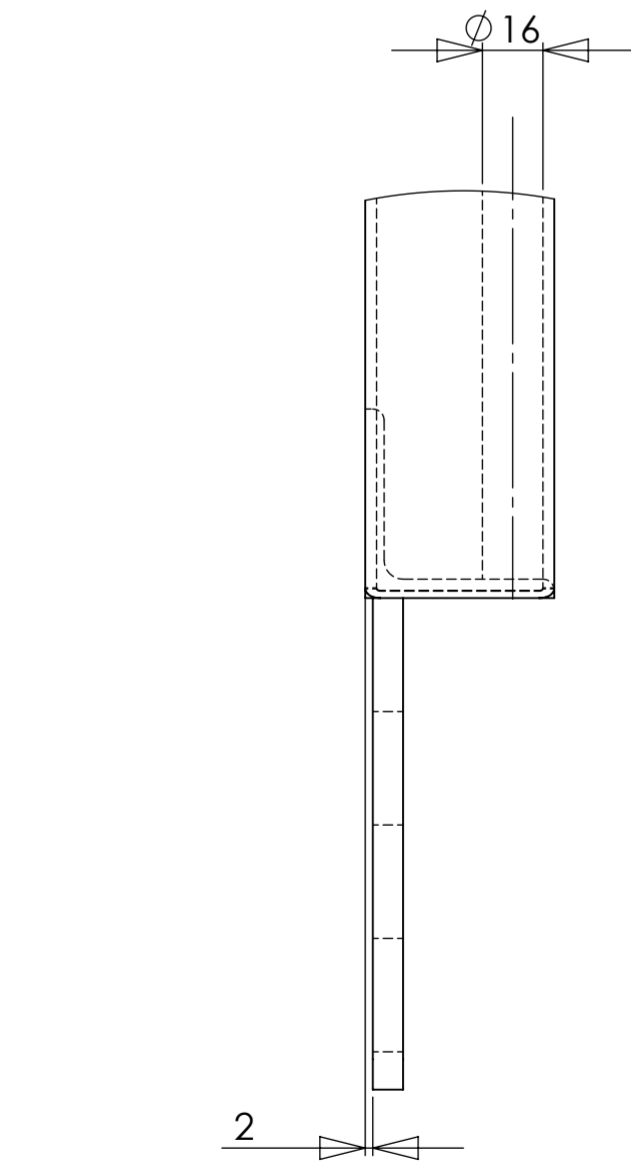

DETAIL F
SCALE 1 : 2

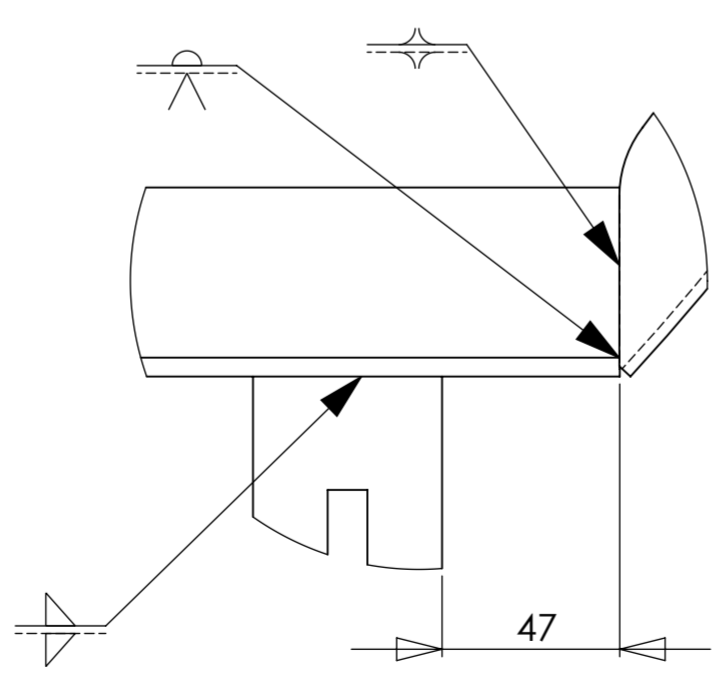

DETAIL C
SCALE 1 : 2

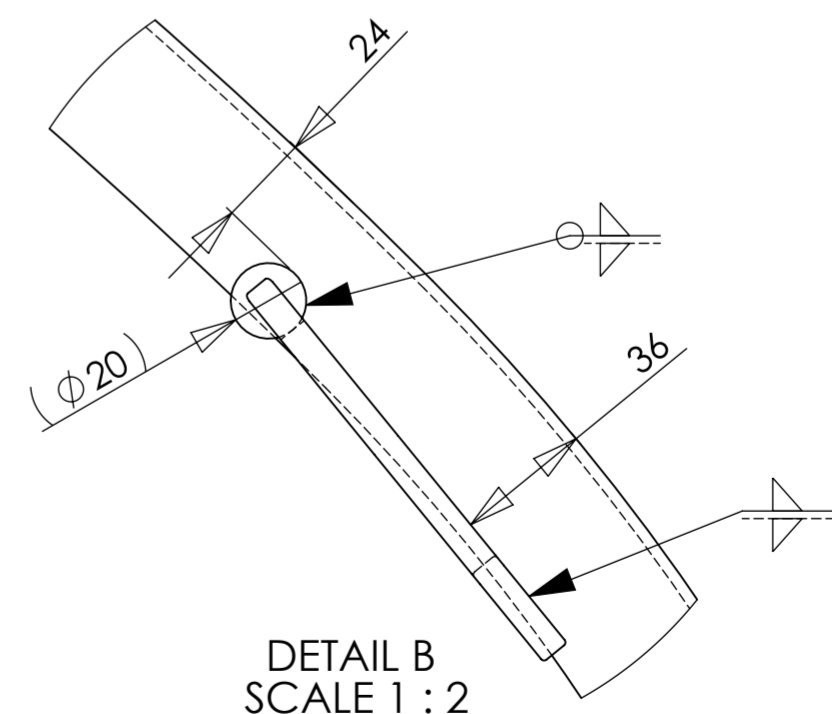

DETAIL B
SCALE 1 : 2

Revisie:	H	Benaming:	Fietshangar zijwand
PDF aanmaak datum:	20-4-2016	Materiaal:	staal
		Nabehandeling:	geen
		Kleur:	
		Tek. nummer:	FHG_A08
		Project code:	
		Getekend door:	Eduard Duijnstee
		Projectie:	⊕ ⊞
		Schaal:	1:10
		Eenheden:	mm
		Formaat:	A2
		Tenzij anders aangegeven: Algemene tolerantie vlg NEN-ISO-2768, klasse m en K	

Alle rechten uitsluitend voorbehouden. Vermenging van mededelingen aan derden, in welke vorm dan ook, is zonder schriftelijke toestemming niet geoorloofd.