

1

2

3

4

A

B

C

D

E

F

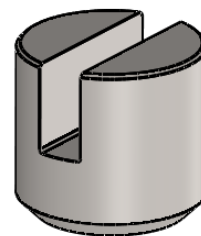
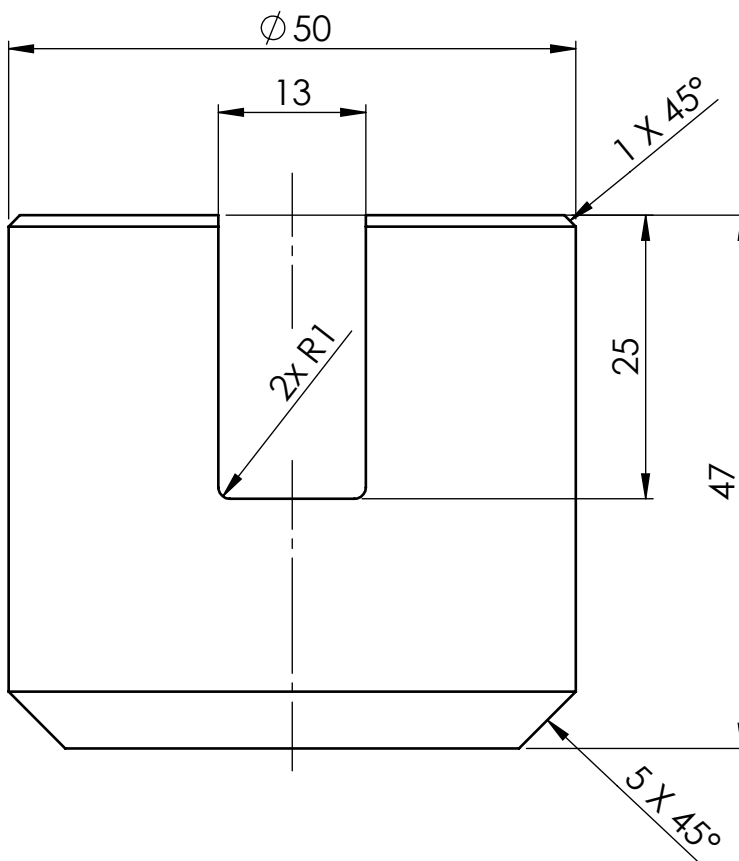

Materiál
1.0045 (S355JR)

Upravil

Tolerance

ISO 8015

Přesnost

ISO 2768 mK

Revize



List1/1