

| | | | |
|-----------------------------|----------|-----------------|----------|
| Formal | B1 2/2 | 319-10-03-05-00 | G200033 |
| Bearbeitungszusatzzeichnung | | Bodenständer | |
| Werkstoff | Material | Menge | Gewicht |
| Alu | 15 | 15 | 22807 kg |

alle Passungsbohrungen $\pm 0,05$
 alle Gewinde- und Durchgangsbohrungen $\pm 0,1$

Farbgebung:
 RAL 7035 seidemat (2 Komponenten)
 gekennzeichnete Flächen ohne Farbgebung
 Gewinde und Passungen abdcken

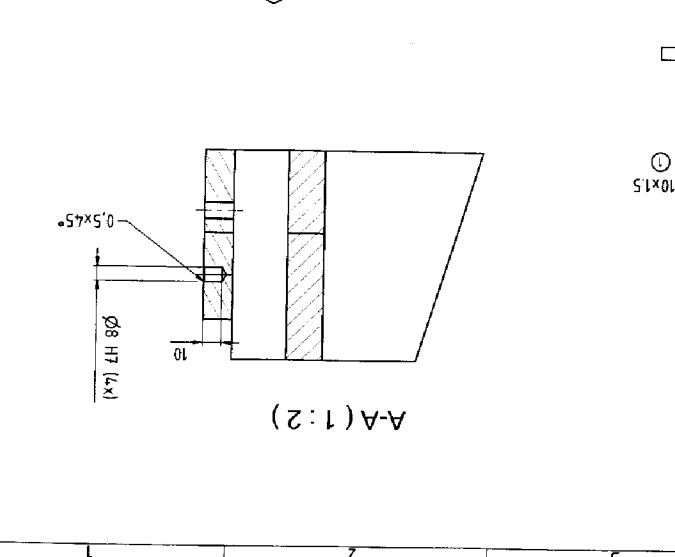
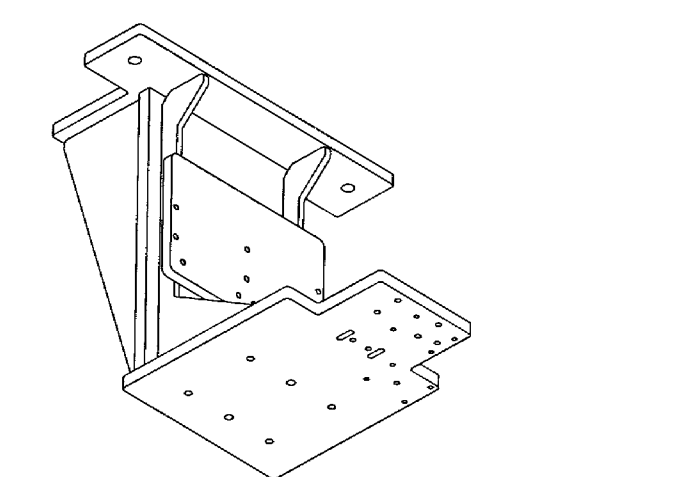

| BOHRUNG | XDIM | YDIM | BEZEICHNUNG |
|---------|-------|------|-------------|
| A1 | 126 | 135 | |
| A2 | 126 | 165 | |
| A3 | 47 | 220 | |
| A4 | 155 | 250 | |
| B1 | 260 | 70 | |
| B2 | 380 | 70 | |
| B3 | 260 | 230 | |
| B4 | 380 | 230 | |
| C1 | 75 | 110 | |
| C2 | 55 | 110 | |
| C3 | 75 | 190 | |
| C4 | 55 | 190 | |
| D1 | 23,5 | 155 | |
| D2 | 68,5 | 155 | |
| D3 | 128,5 | 215 | |
| D4 | 178,5 | 215 | |
| D5 | 23,5 | 230 | |
| D6 | 68,5 | 230 | |
| D7 | 128,5 | 290 | |
| D8 | 178,5 | 290 | |
| E1 | 260 | 150 | |
| E2 | 380 | 150 | |

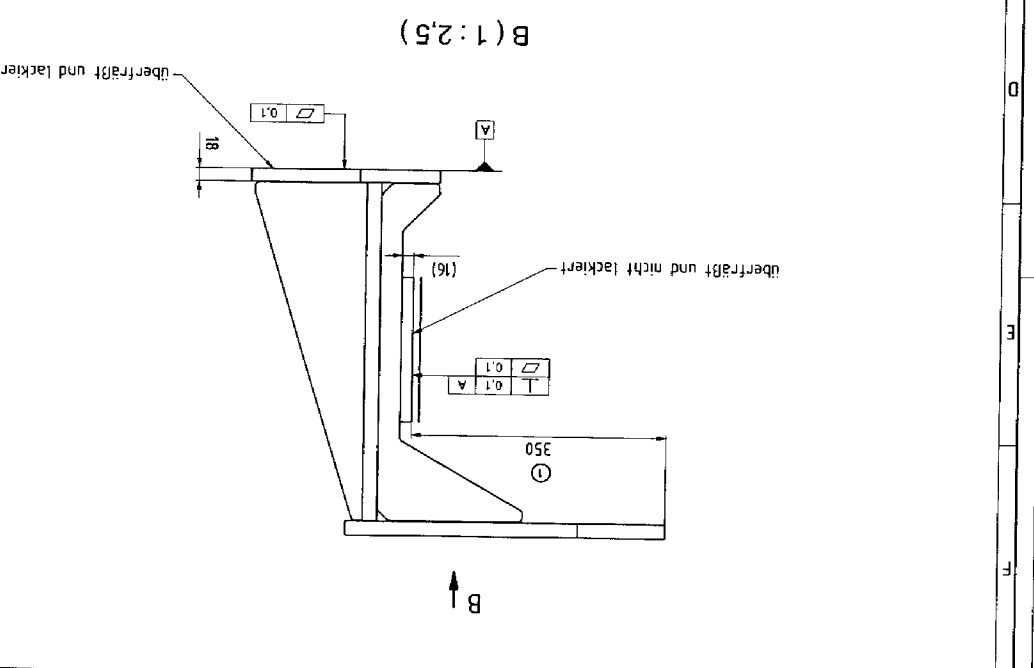
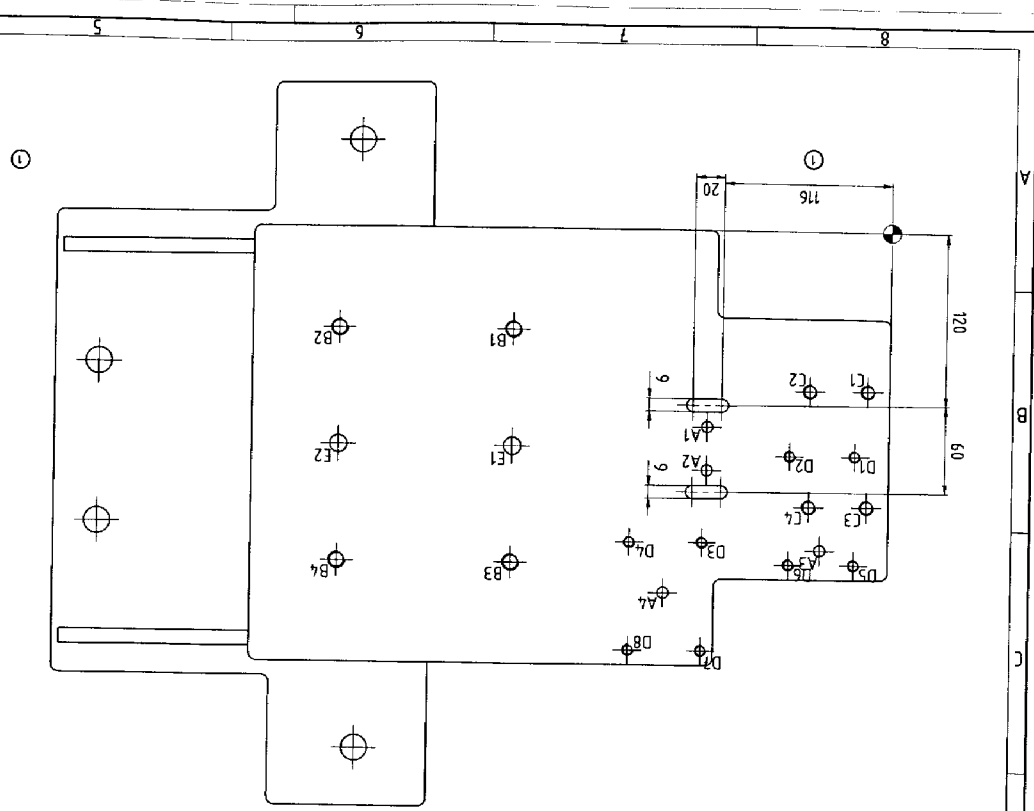

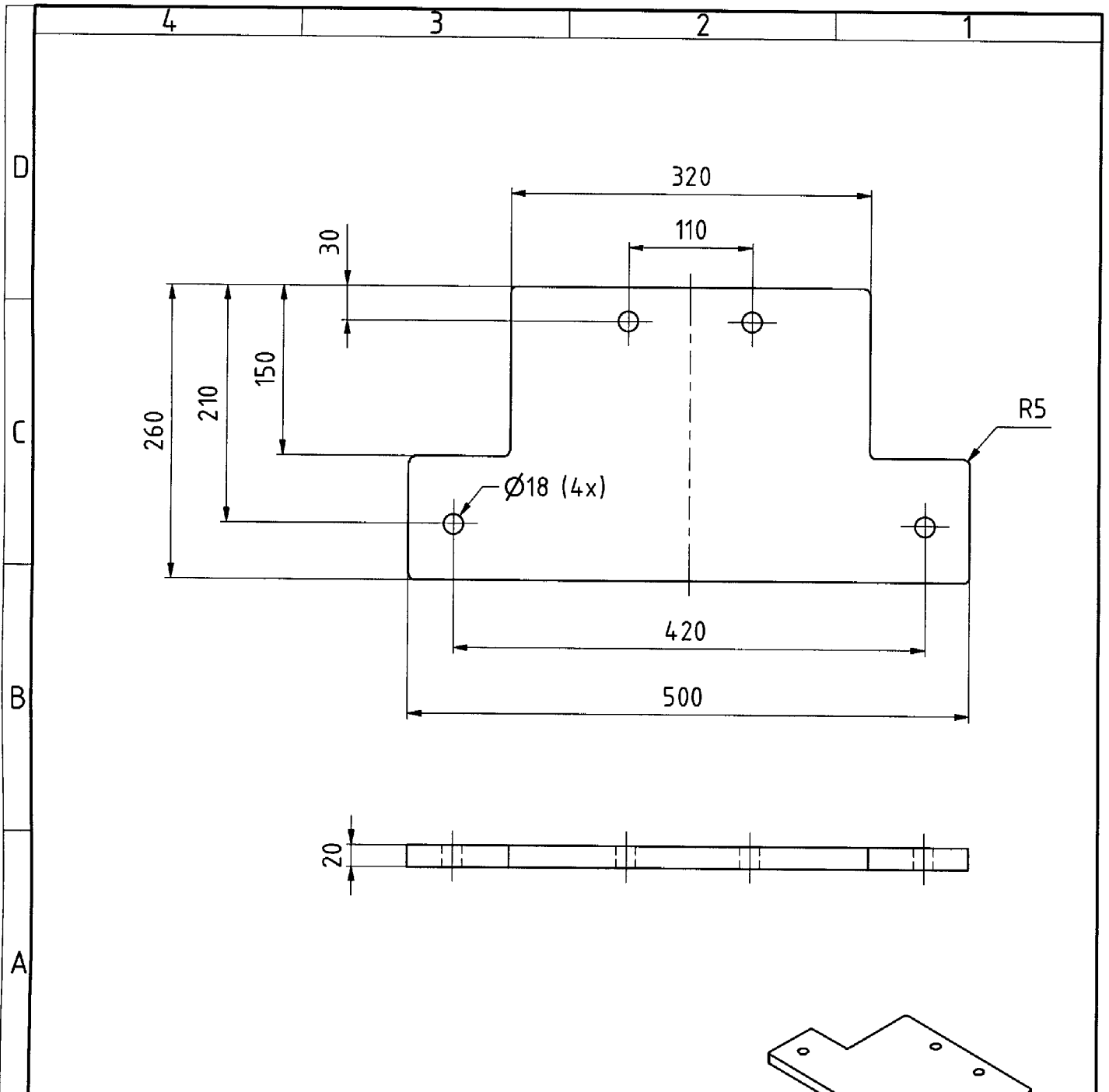

Eckenradien R5
Kanten gebrochen

✓ Rz25

| | | | | | | | | | | | |
|------|----------|-------|------|--|------|------------------------------|--|-------------|-------------------|-----------------|--|
| | | | | Allgemeintoleranzen nach DIN ISO 2768 - m | | Oberfläche nach DIN ISO 1302 | | Maßstab 1:5 | Gewicht 16,008 kg | Menge | |
| | | | | Werkstückkanten DIN 6781 $\sqrt{0.3}$ $\sqrt{0.3}$ | | | | | | S235JR | |
| | | | | Datum | Name | Fußplatte | | | | | |
| | | | | Bearb. 05.11.2020 | TS | | | | | | |
| | | | | Gepr. | | | | | | | |
| | | | | Norm | | | | | | | |
| | | | | Gez. 11.11.2020 | STR | G200033 | | | | 319-10-03-05-01 | |
| | | | | | | | | | | Format A4 | |
| Nr.: | Änderung | Datum | Name | EDV Nr. | | | | | | Bl. 1 | |

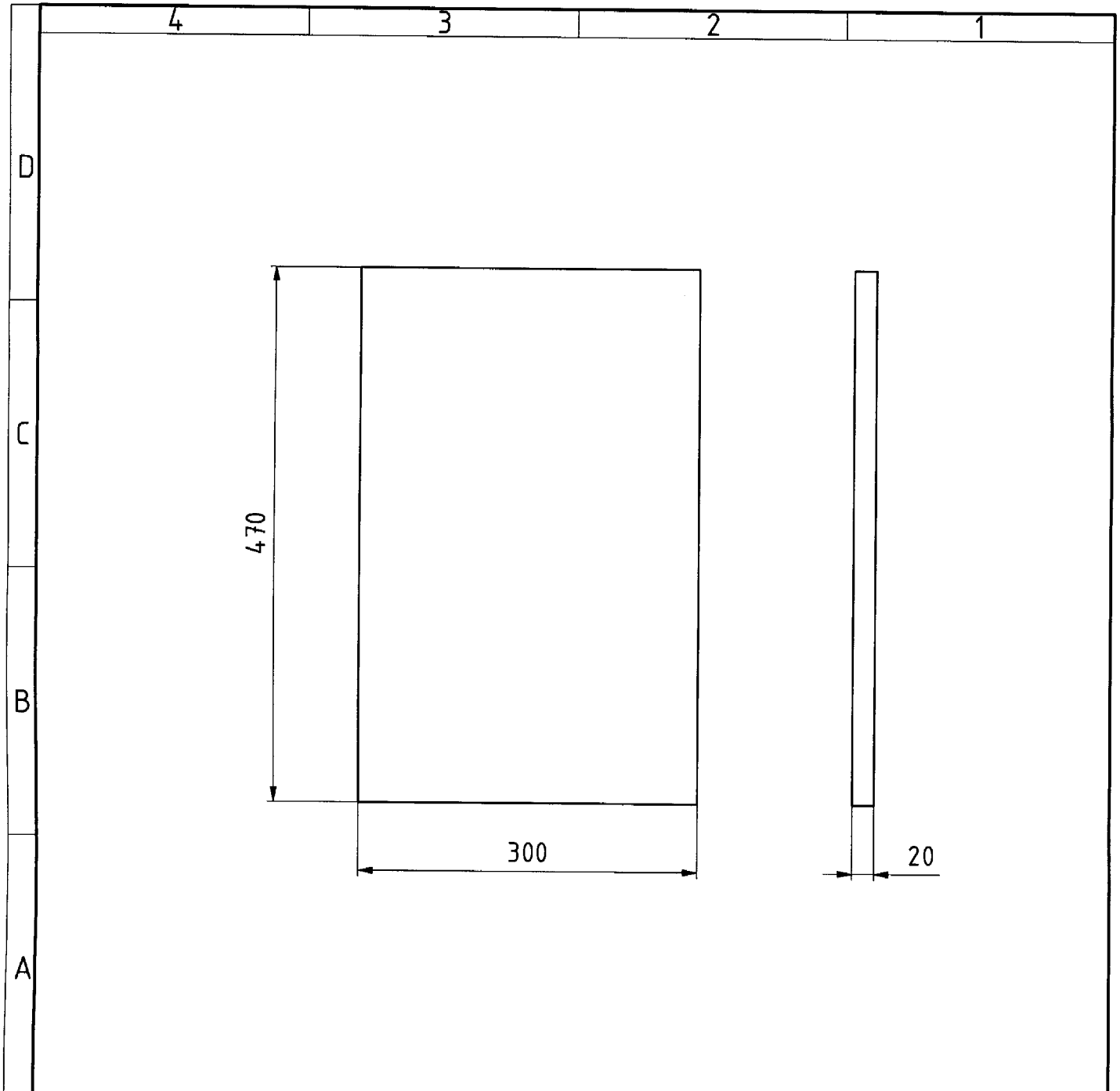

Kanten gebrochen

√ Rz25

| | | | | | | | | | | | |
|------|----------|-------|------|--|--|------------------------------------|--|-----------------|--|-------------------------|--|
| | | | | Allgemeintoleranzen nach DIN ISO 2768 - m | | Oberfläche nach DIN ISO 1302 | | Maßstab 1:5 | | Gewicht 22,137 kg Menge | |
| | | | | Werkstückkanten DIN 6784 | | | | S235JR | | | |
| | | | | Datum | | Name | | Seitenplatte | | | |
| | | | | Bearb. 05.11.2020 | | TS | | | | | |
| | | | | Gepr. | | | | | | | |
| | | | | Norm | | | | | | | |
| | | | | Gez. 11.11.2020 | | STR | | | | | |
| | | | | G200033 | | | | 319-10-03-05-02 | | | |
| | | | | | | | | Format A4 | | | |
| | | | | | | | | Bl 1 | | | |
| Nr.: | Änderung | Datum | Name | EDV Nr. | | | | | | | |

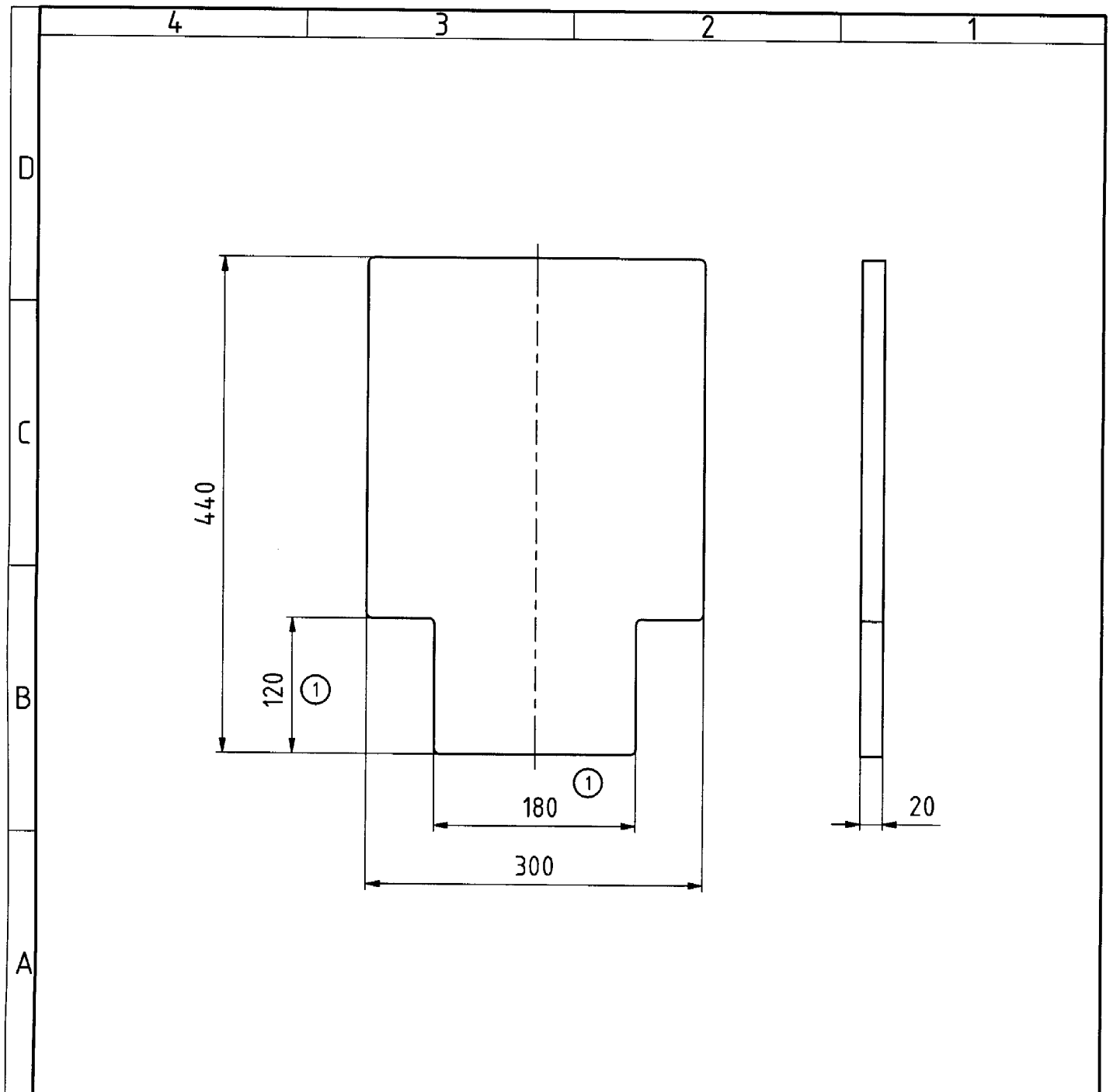

Eckenradien R5
Kanten gebrochen

√ Rz25

| | | | | | | | | | | | |
|---------------|--|----------|--|--|--|------------------------------------|--|-----------------|--|-------------------------|--|
| | | | | Allgemeintoleranzen nach DIN ISO 2768 - m | | Oberfläche nach DIN ISO 1302 | | Maßstab 1:5 | | Gewicht 18,460 kg Menge | |
| | | | | Werkstückkanten DIN 6784 | | | | S235JR | | | |
| | | | | Datum | | Name | | Kopfplatte | | | |
| | | | | Bearb. 05.11.2020 | | TS | | | | | |
| | | | | Gepr. | | | | | | | |
| | | | | Norm | | | | | | | |
| | | | | Gez. 11.11.2020 | | STR | | | | | |
| | | | | G200033 | | | | 319-10-03-05-03 | | | |
| 1 Maße | | 25.11.20 | | TS | | | | | | Format A4 | |
| Nr.: Änderung | | Datum | | Name | | EDV Nr. | | | | Bl 1 | |

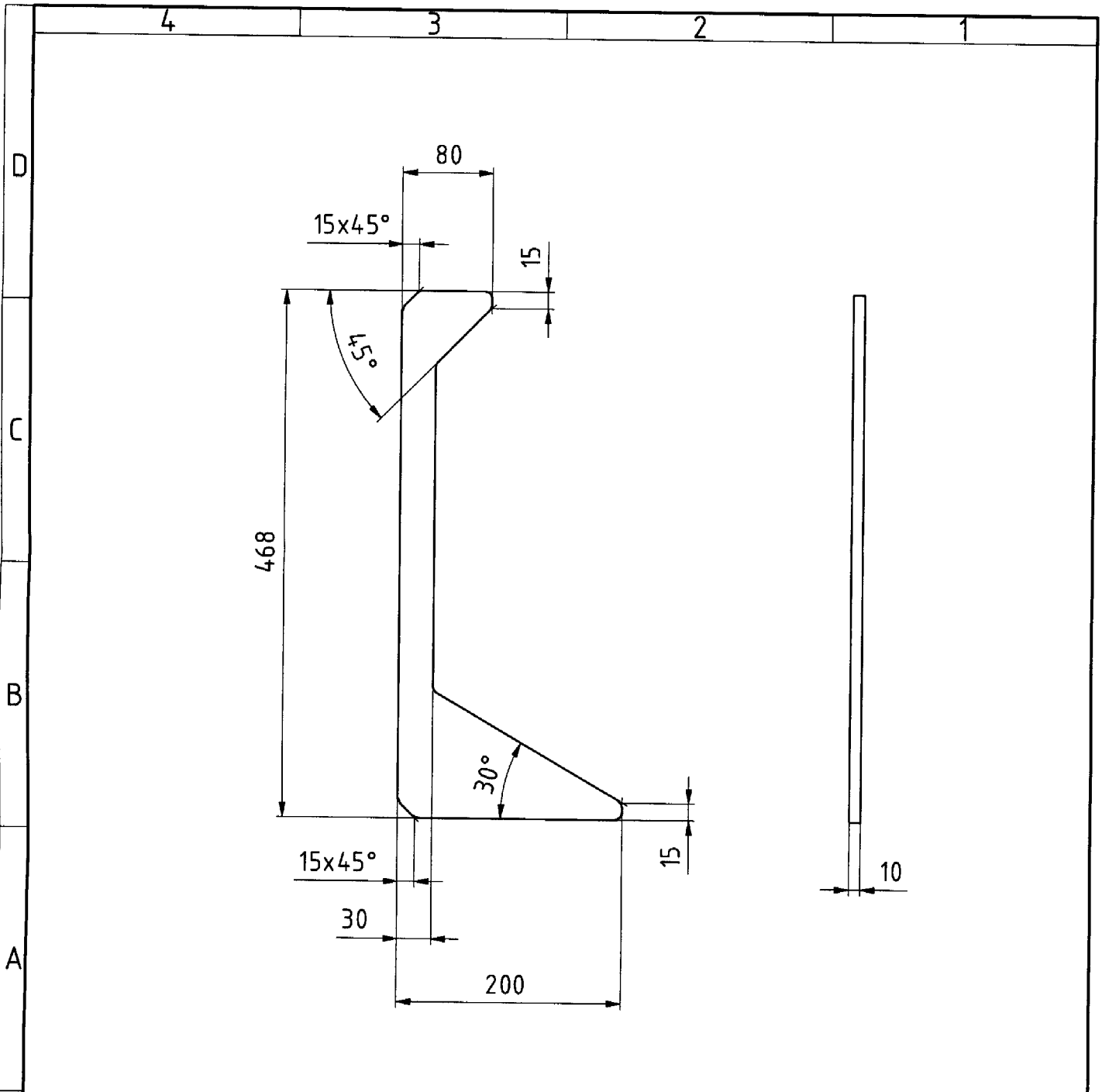

Eckenradien R5
Kanten gebrochen

√ Rz25

| | | | | | | | | | | | |
|------|----------|-------|------|---|--|------------------------------|--|-----------------|--|------------------------|--|
| | | | | Allgemeintoleranzen nach DIN ISO 2768 - m | | Oberfläche nach DIN ISO 1302 | | Maßstab 1:5 | | Gewicht 2,096 kg Menge | |
| | | | | Werkstückkanten DIN 6784 | | $\sqrt{0.3}$ $\sqrt{0.3}$ | | S235JR | | | |
| | | | | Datum | | Name | | Rippe | | | |
| | | | | Bearb. 05.11.2020 | | TS | | | | | |
| | | | | Gepr. | | | | | | | |
| | | | | Norm | | | | | | | |
| | | | | Gez. 11.11.2020 | | STR | | | | | |
| | | | | G200033 | | | | 319-10-03-05-04 | | | |
| | | | | | | | | Format A4 | | | |
| | | | | | | | | Bl 1 | | | |
| Nr.: | Änderung | Datum | Name | EDV Nr. | | | | | | | |

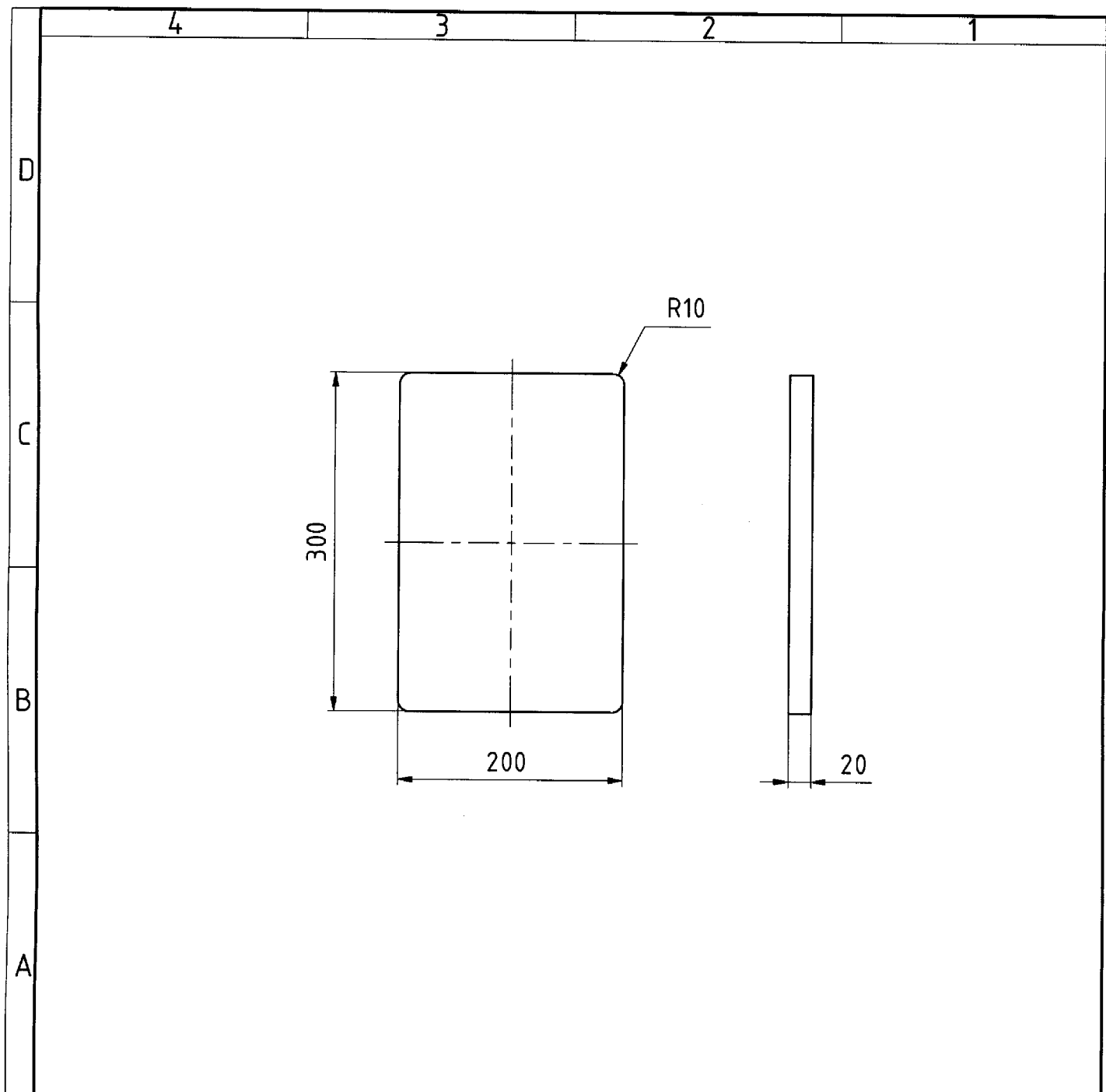

Kanten gebrochen

✓ Rz25

| | | | | | | | | | | | |
|------|--|----------|--|--|--|------------------------------------|--|-----------------|--|------------------------|--|
| | | | | Allgemeintoleranzen nach DIN ISO 2768 - m | | Oberfläche nach DIN ISO 1302 | | Maßstab 1:5 | | Gewicht 9,407 kg Menge | |
| | | | | Werkstückkanten DIN 6782 | | | | S235 JR | | | |
| | | | | Datum | | Name | | Frontplatte | | | |
| | | | | Bearb. 05.11.2020 | | TS | | | | | |
| | | | | Gepr. | | | | | | | |
| | | | | Norm | | | | | | | |
| | | | | Gez. 11.11.2020 | | STR | | | | | |
| | | | | G200033 | | | | 319-10-03-05-07 | | | |
| | | | | | | | | Format A4 | | | |
| | | | | | | | | Bl 1 | | | |
| Nr.: | | Änderung | | Datum | | Name | | EDV Nr. | | | |