

FOLDED VIEW

Front stakes must fit in rear bottom rods

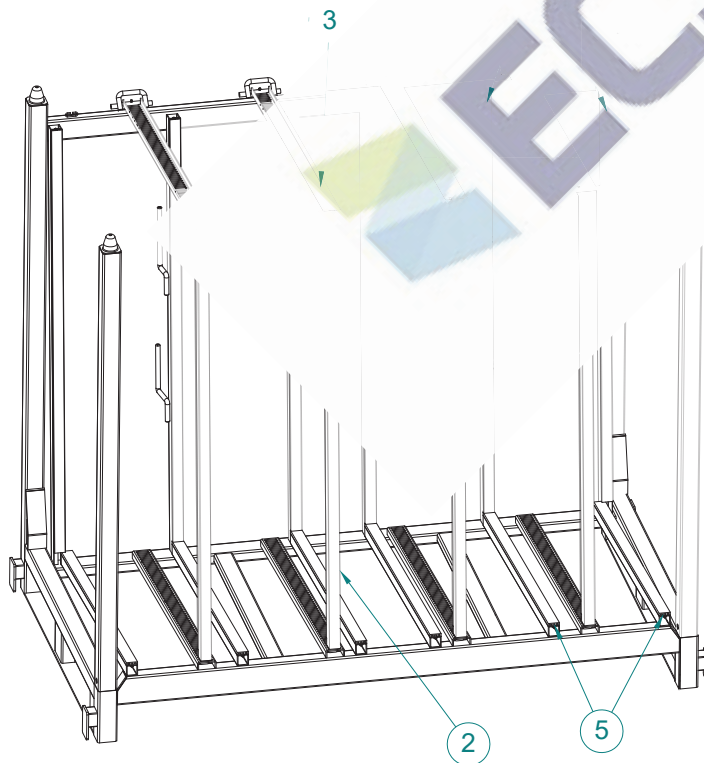

GENERAL

Rack fabricated from mild steel sections.
All bolts, nuts and washers to be plated.
Remove all burrs and sharp edges.

STEEL

Quality should be Q235 or better.
Maximum allowed thickness variation = 10%.

DIMENSIONAL TOLERANCES

General dimensional tolerances unless otherwise stated according to:

Linear Diagonal	
0-500mm ±1.0mm	0-1000mm <2mm
501-1000mm ±1.5mm	1001-2000mm <3mm
1001-2000mm ±2.0mm	2001-3000mm <4mm
2001-4000mm ±2.5mm	3001-4000mm <5mm
4001-6000mm ±3.0mm	4001- <7mm

Uprightness

-100mm <1.0mm
100-200mm <1.5mm
200-300mm <2.0mm
300- <2.5mm

General tolerance for machined parts according to ISO 2768-1 medium.

WELDING

All welds shall be full strength and shall not be less than 0.8x the thickness of the thinnest material being welded. All welds shall be free from porosity, slag and splatter.

Unless otherwise stated, all welds shall be continuous.
Welders shall be qualified in accordance with ISO 9606-1
All welds shall be made according to ISO 15607.

SURFACE TREATMENT

Degreasing or sand-blasting
Painted : Refer to the purchase Order
Minimum local coating thickness : 55µm
Minimum mean coating thickness : 70µm

Note : Weight values are rough, for information purposes only.

6	6	Alveolar omega rubber band	30x8 L=1200	
5	6	Solid omega rubber band	30x8 L=780	
4	2	Front Stake		
3	4	Locking arm		
2	4	Locking bar		
1	1	Body		
Item	Qty	Title	Product No./ Draw No. / Size	Note

Sheet
1/2

Drawn	Scale	Weight	Volume		Rev.
	1:14	99kg			



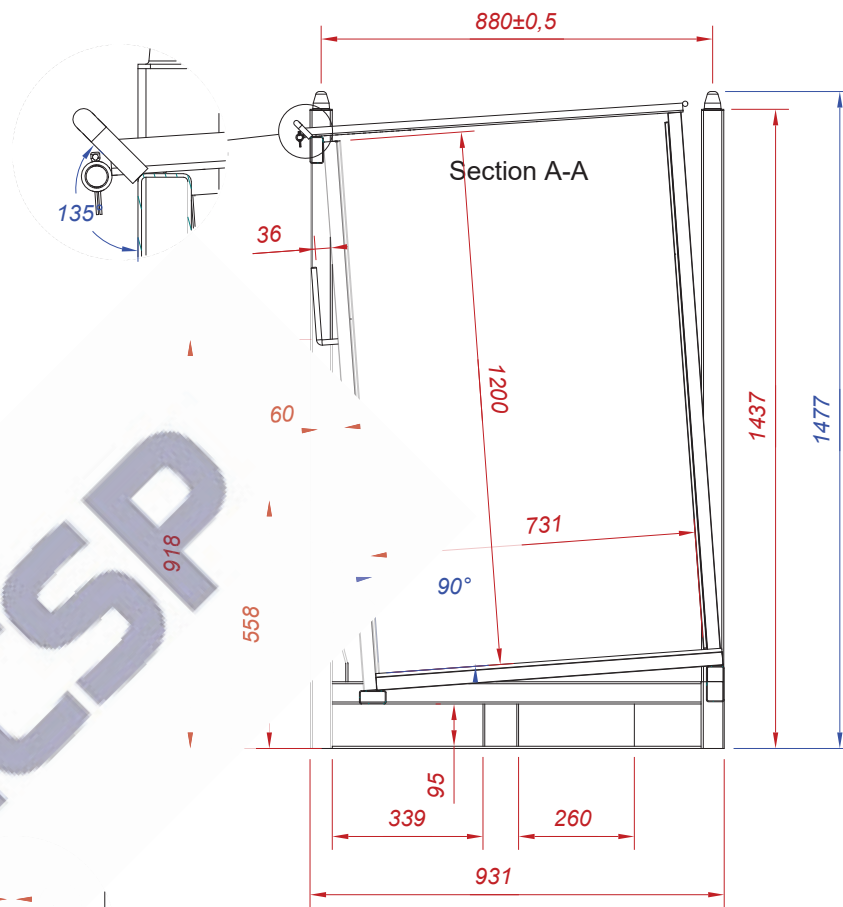
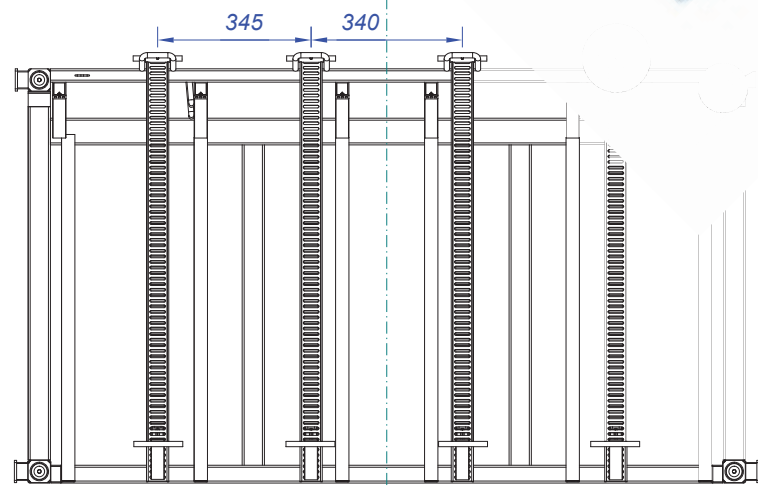
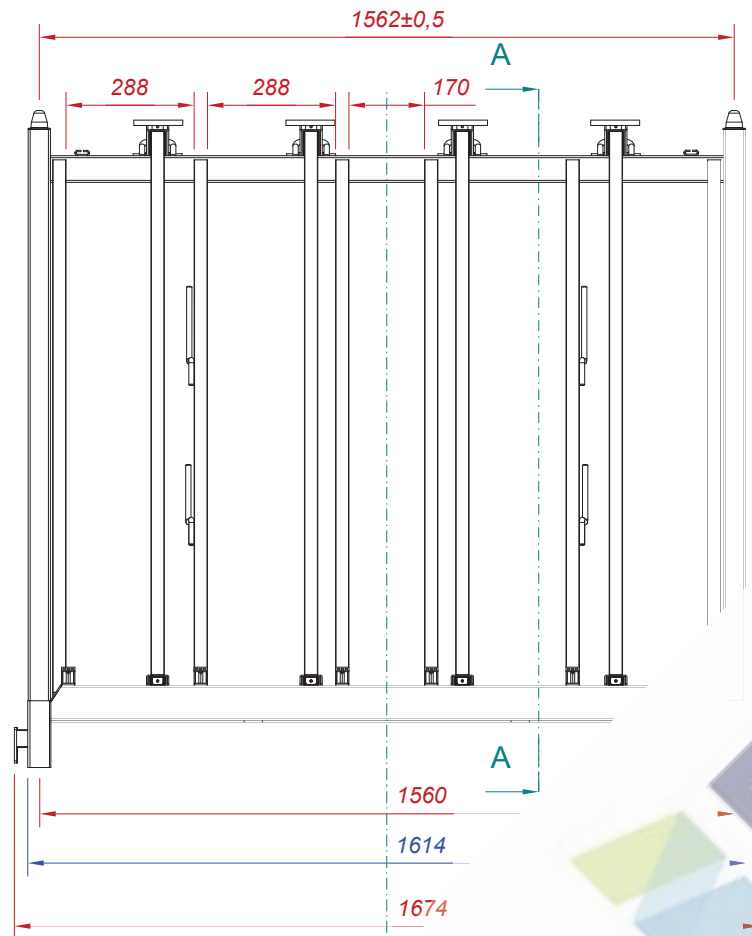

ECSP

Functionnal dimensions

				Sheet	
				2/2	
Drawn	Scale	Weight	Volume		Rev.
		99kg			



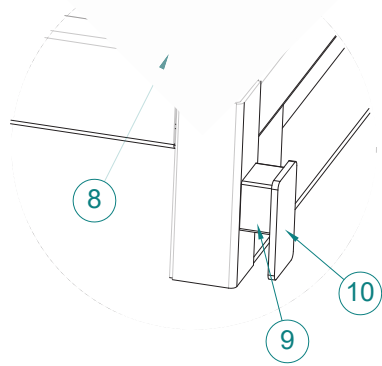
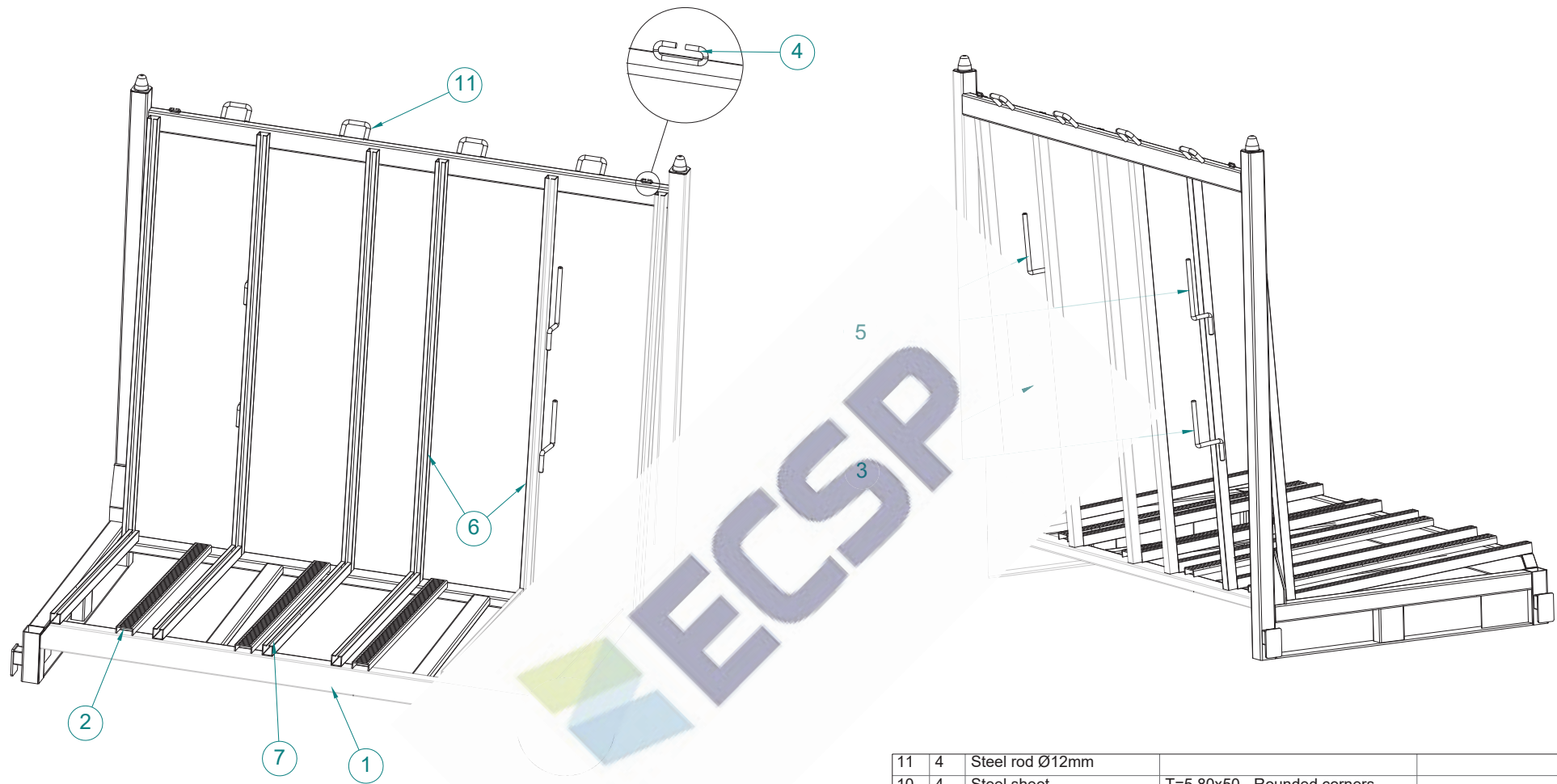

11	4	Steel rod Ø12mm		
10	4	Steel sheet	T=5 80x50 - Rounded corners	
9	4	Steel tube	40x40x2 L=25	
8	2	Steel sheet	T=3 40x35	
7	6	Steel open tube	30x30x2x7 L=780	
6	6	Steel open tube	30x30x7x2 L=1236	
5	2	Steel rod D=12		
4	2	Steel ring D=3		
3	2	Steel rod D=12		
2	4	Steel sheet T=3		
1	1	Base		
Item	Qty	Title	Product No./ Draw No. / Size	Note

Body

Sheet
1/2

Drawn	Scale	Weight 65 Kg	Volume		Rev.
-------	-------	-----------------	--------	--	------



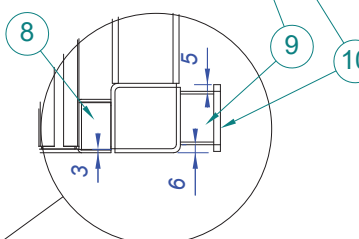
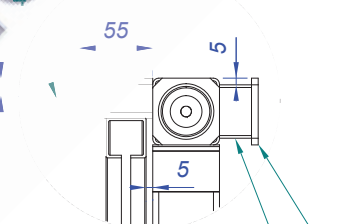
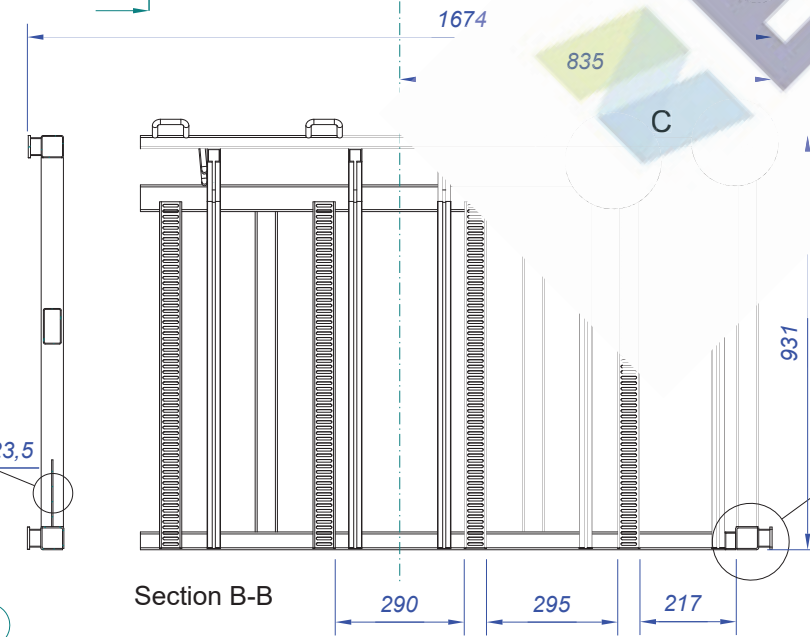
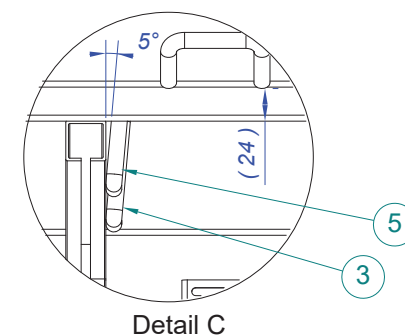
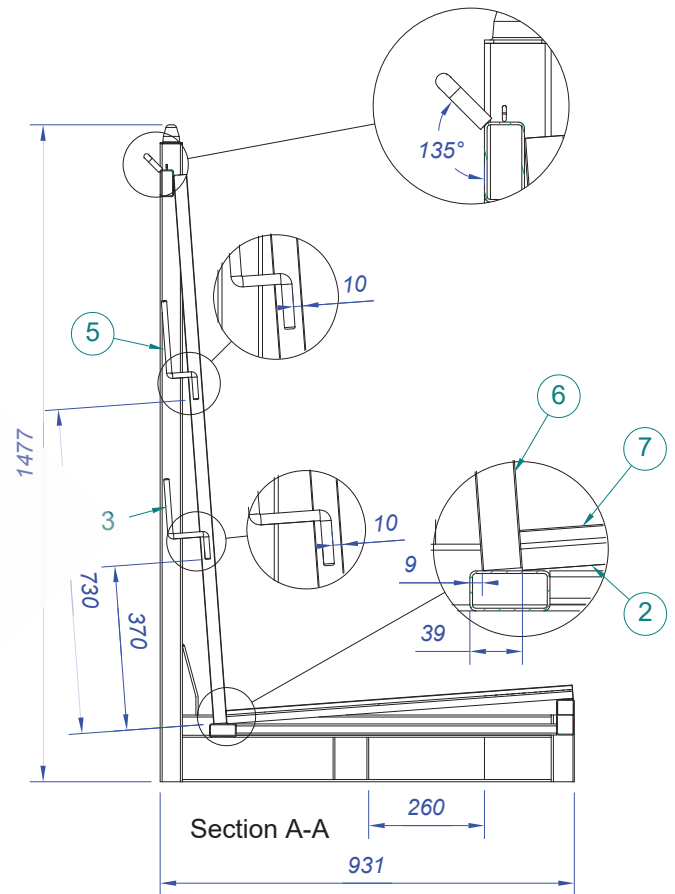
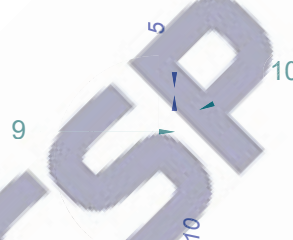
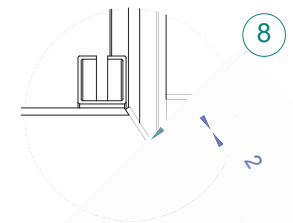
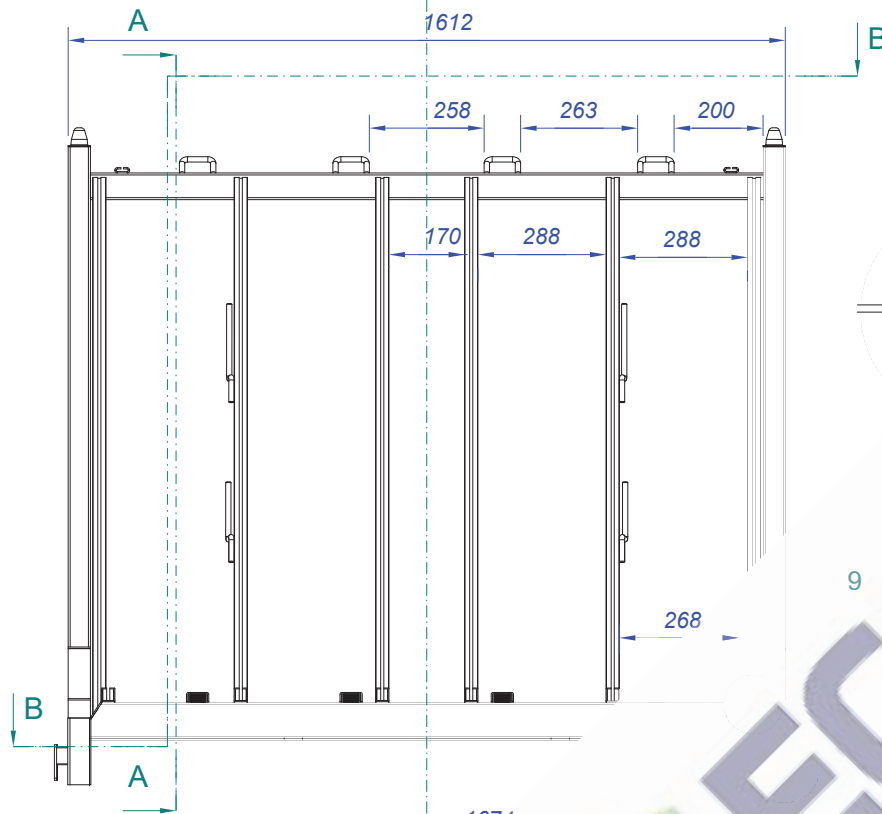

Body					Sheet	
					2/2	
Drawn	Scale	Weight	Volume			Rev.
	1:12	65 Kg				

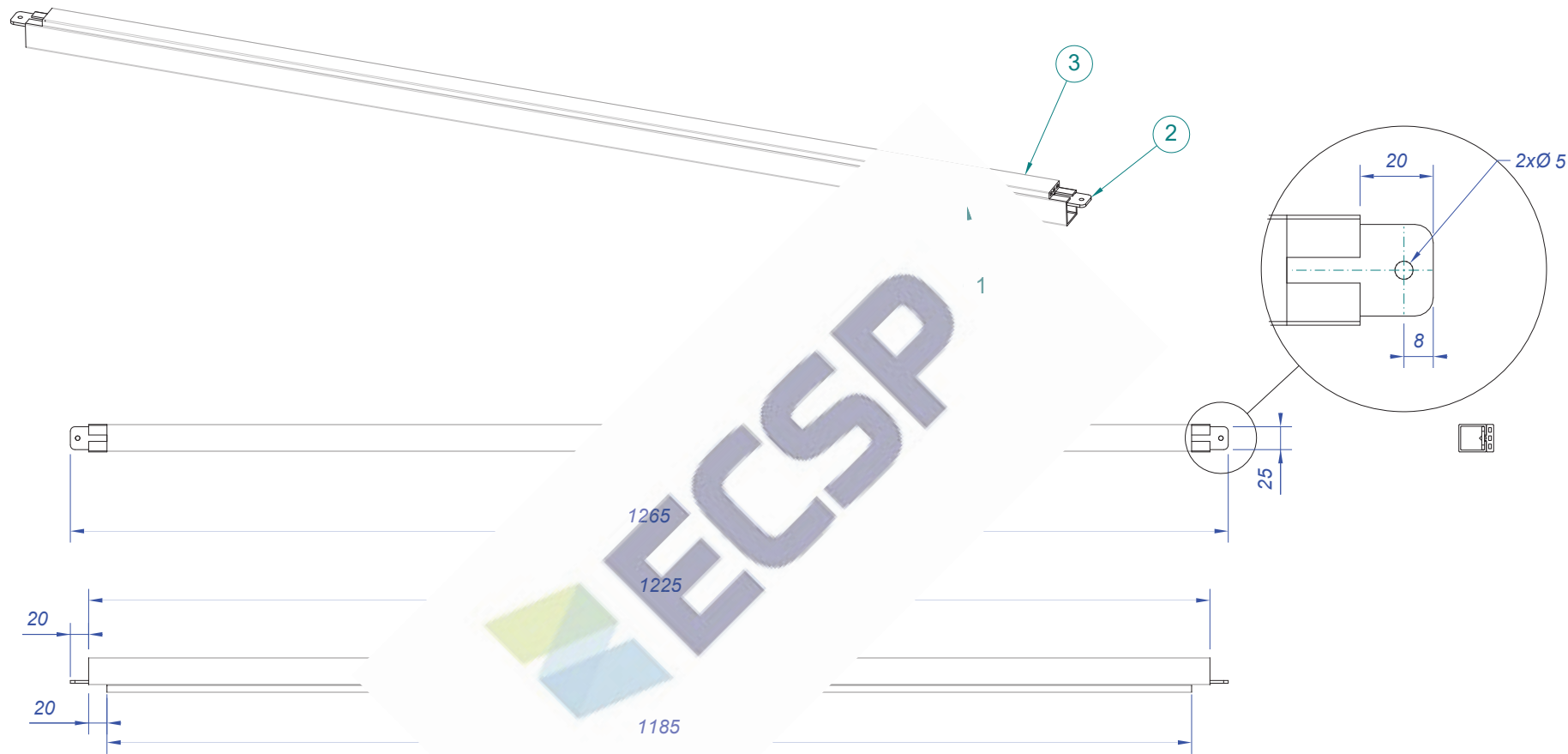

3	1	Alveolar omega rubber band	30x8 L=1185	
2	2	Steel sheet	T=3 40x24	
1	1	Steel open tube	30x30x2x7 L=1225	
Item	Qty	Title	Product No. / Draw No. / Size	Note

Locking bar

Sheet

Drawn	Scale	Weight	Volume		Rev.
	1:5				



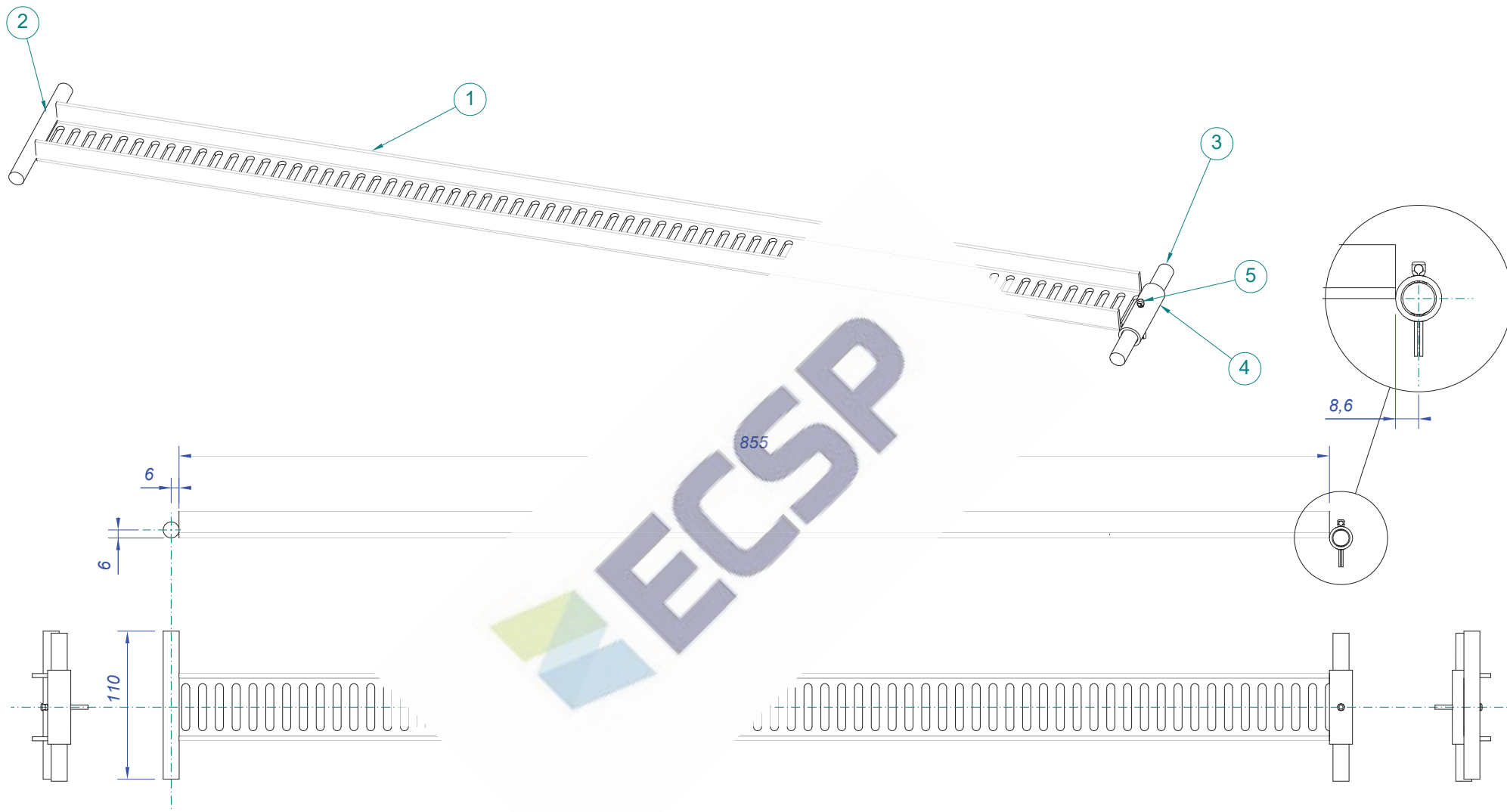

5	1	Cotter pin	3.2x30	
4	1	Steel tube 17.2x2		
3	1	Steel rod Ø12		
2	1	Steel rod	Ø12 L=110	
1	1	Steel sheet T=3		
Item	Qty	Title	Product No./ Draw No. / Size	Note

Locking arm

Sheet

Drawn	Scale	Weight	Volume		Drawing number	Rev.
	1:3					



Hole to weld the tubes together

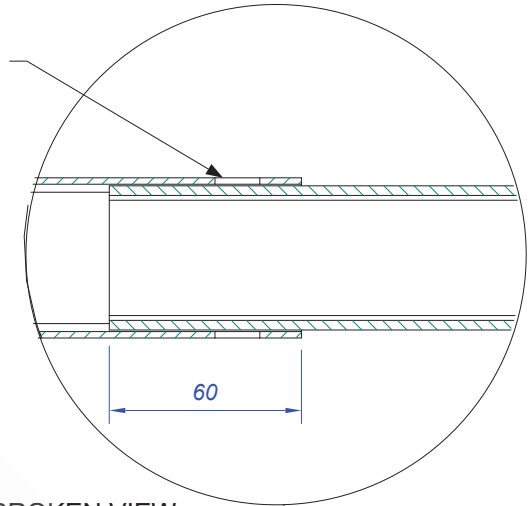

BROKEN VIEW

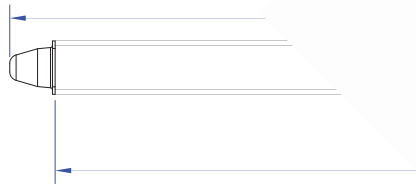
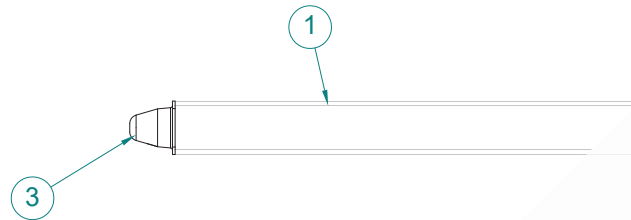
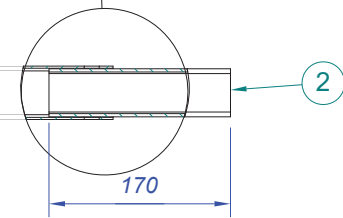

1437

1284

110



3	1	Stacking cone		
2	1	Steel tube	45x45x3 L=170	
1	1	Steel tube	50x50x2 L=1284	
Item	Qty	Title	Product No./ Draw No. / Size	Note

Front stake

Sheet

Drawn	Scale	Weight	Volume		Rev.
	1:5				



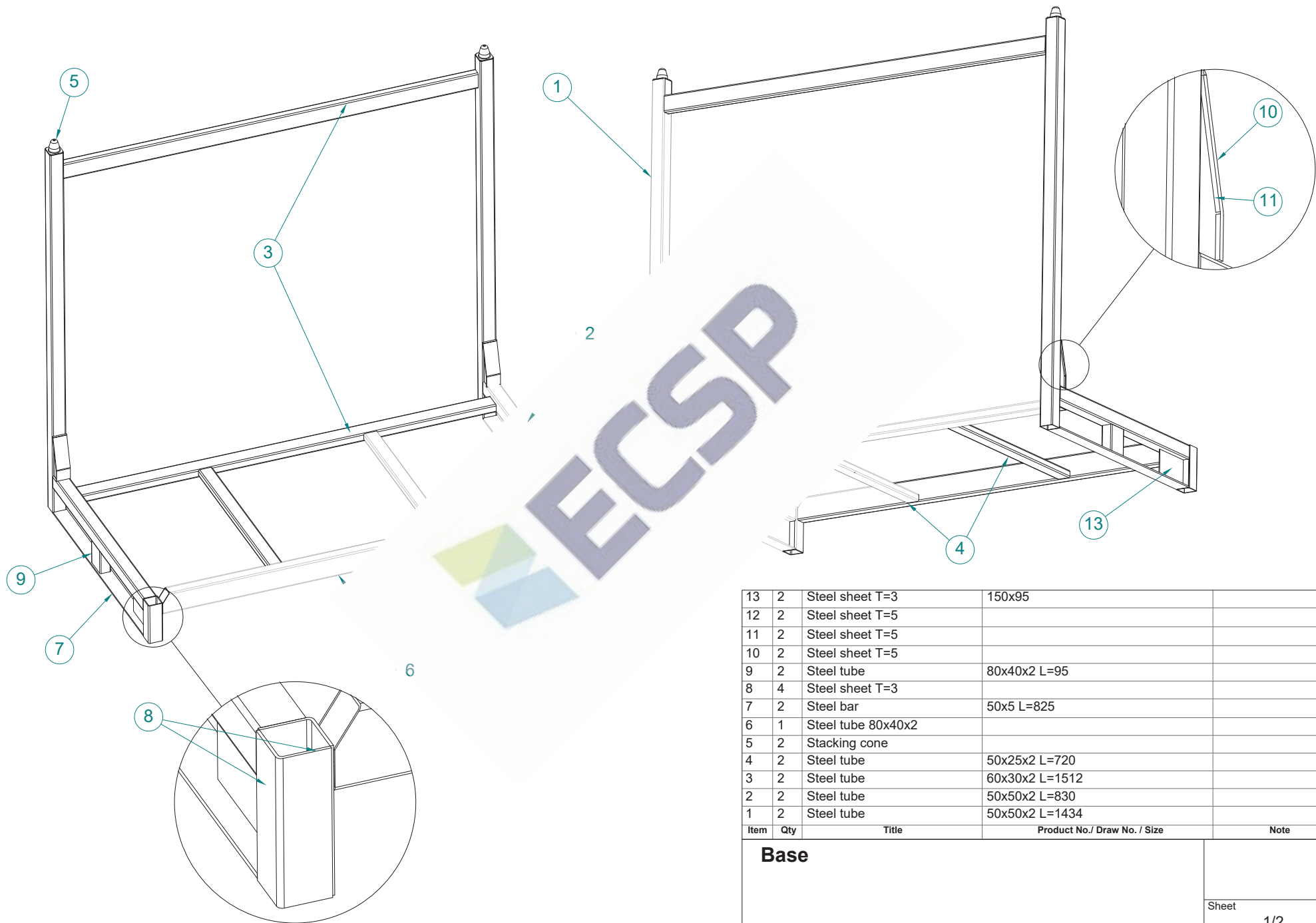

13	2	Steel sheet T=3	150x95	
12	2	Steel sheet T=5		
11	2	Steel sheet T=5		
10	2	Steel sheet T=5		
9	2	Steel tube	80x40x2 L=95	
8	4	Steel sheet T=3		
7	2	Steel bar	50x5 L=825	
6	1	Steel tube 80x40x2		
5	2	Stacking cone		
4	2	Steel tube	50x25x2 L=720	
3	2	Steel tube	60x30x2 L=1512	
2	2	Steel tube	50x50x2 L=830	
1	2	Steel tube	50x50x2 L=1434	
Item	Qty	Title	Product No./ Draw No. / Size	Note

Base

Sheet
1/2

Drawn	Scale	Weight	Volume		Rev.
	1:12	37 Kg			



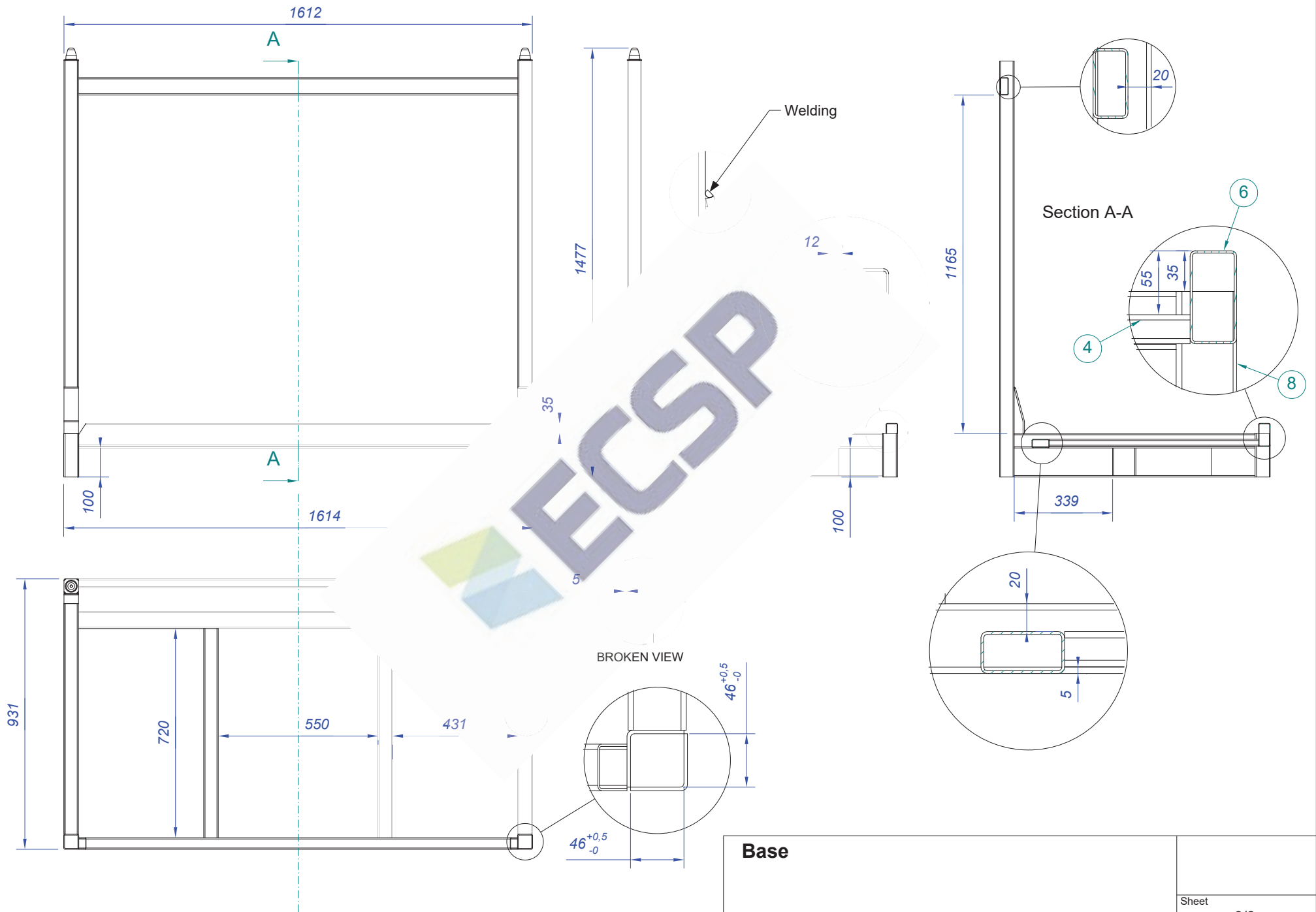

Base				Sheet	
Drawn	Scale	Weight	Volume	2/2	
	1:12	37 Kg			Rev.



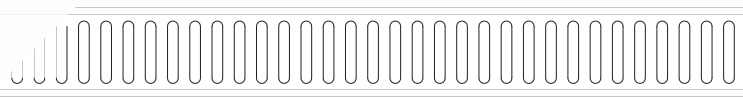
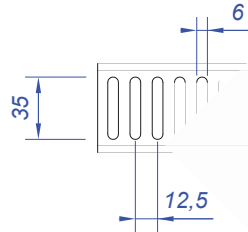
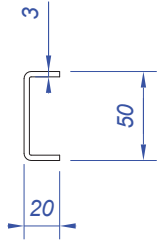
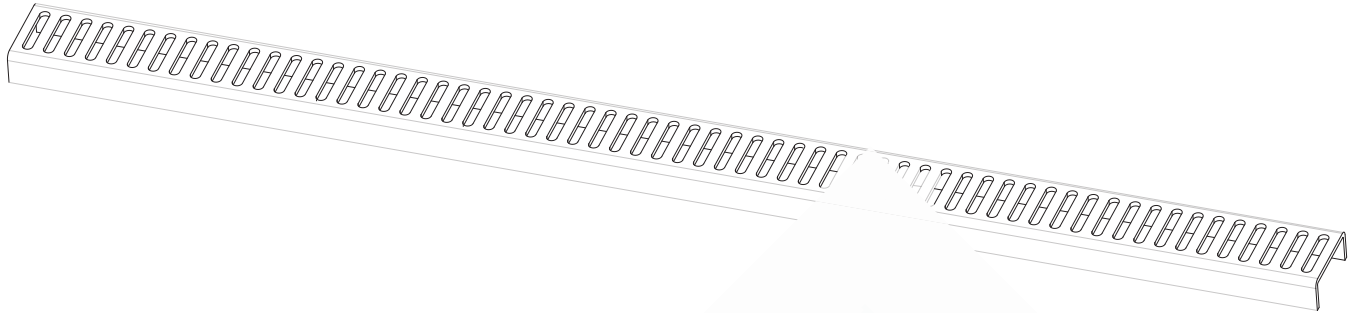

WECSPA

Steel sheet T=3

Steel sheet T=3					Sheet	
Drawn	Scale	Weight	Volume	Drawing number	Rev.	
	1:3					



Edges must be rounded

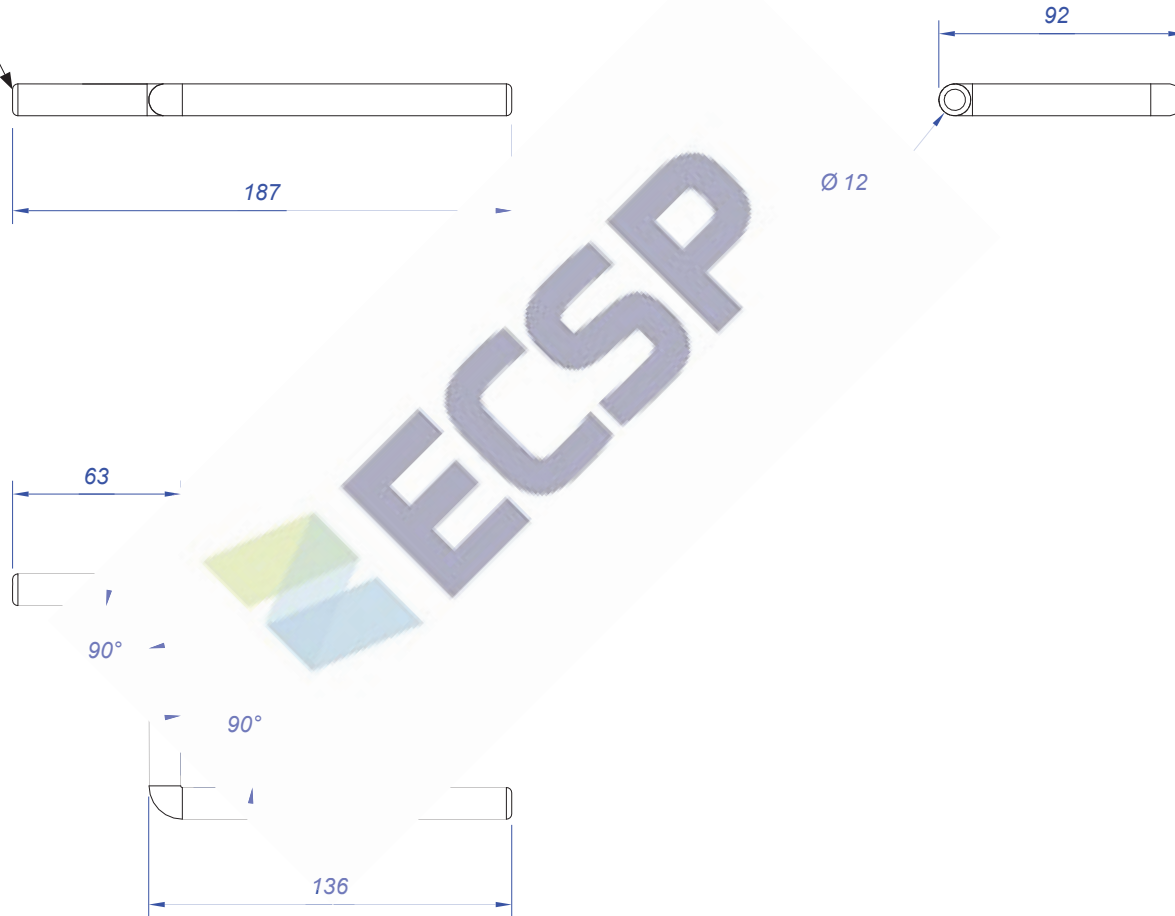

Steel rod D=12					Sheet	
Drawn	Scale	Weight	Volume		Rev.	
	1:1					





Ø 12

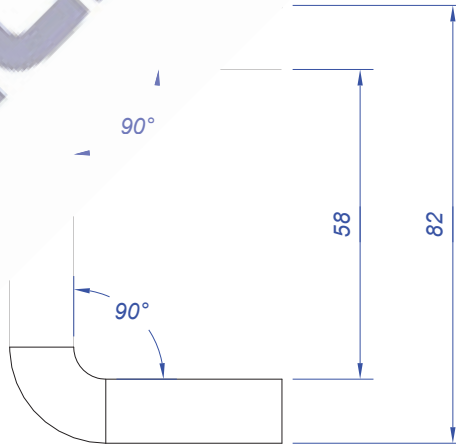
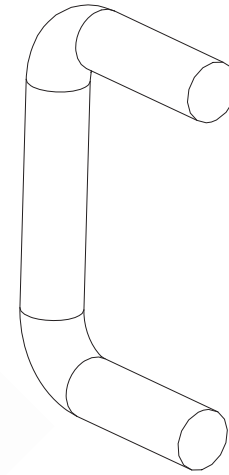

Steel rod D=12					Sheet	
Drawn	Scale	Weight	Volume	Drawing number	Rev.	
	1:1					



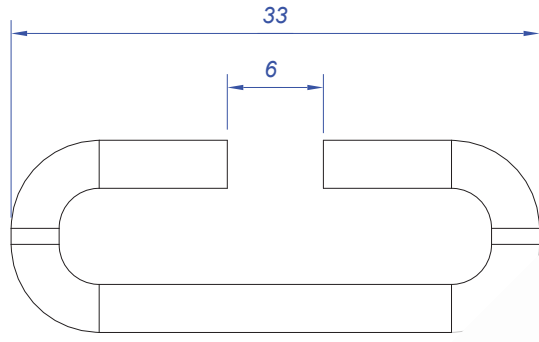

12

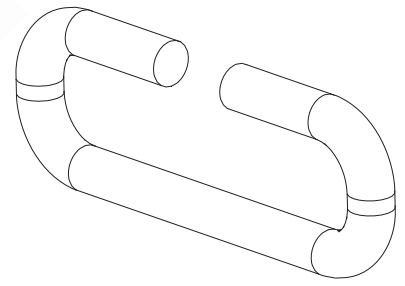
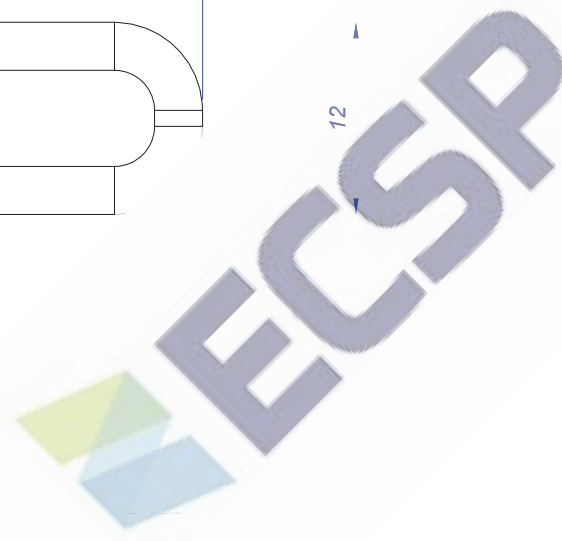

Steel rod D=3					
					Sheet
Drawn	Scale	Weight	Volume		
	3:1				



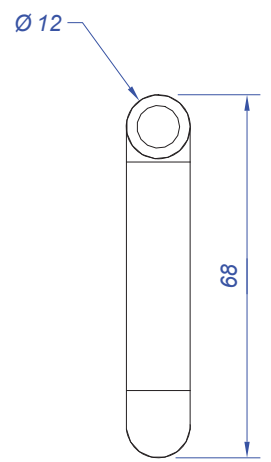
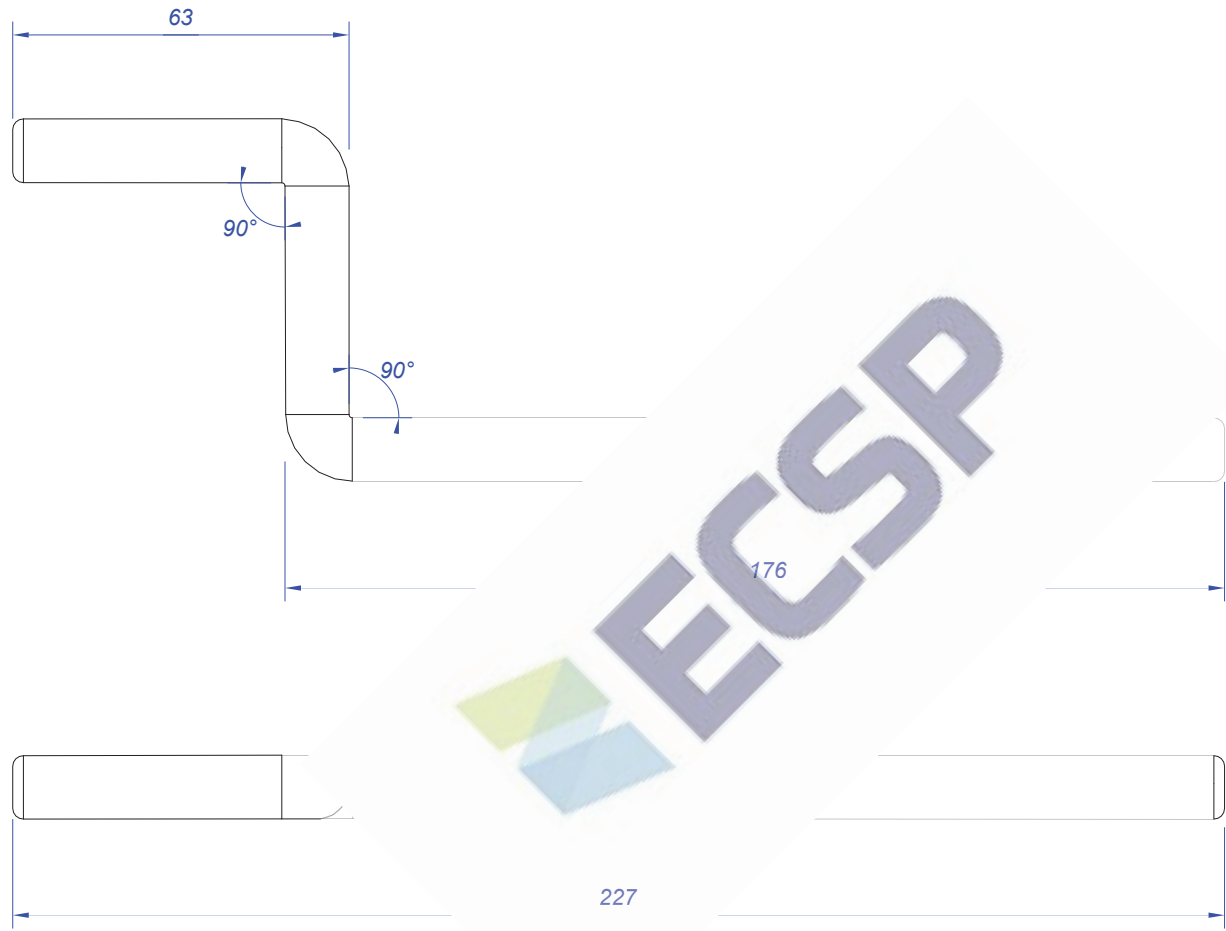

Steel rod D=12						
					Sheet	
Drawn	Scale	Weight	Volume			Rev.
	1:1					



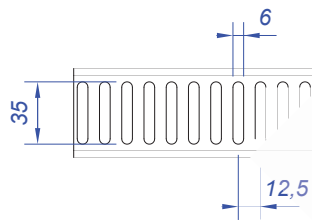
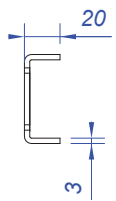

855

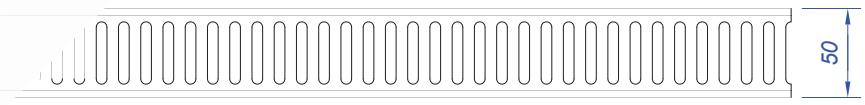

50



Steel sheet T=3					Sheet	
Drawn	Scale	Weight	Volume	Drawing number	Rev.	
	1:3					



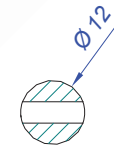
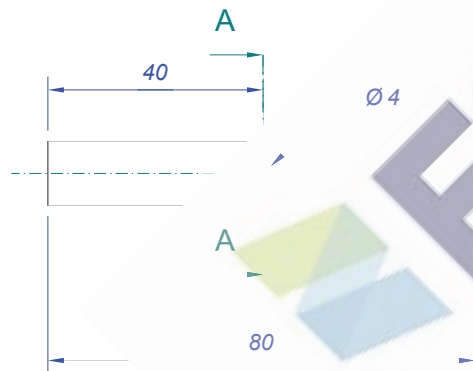
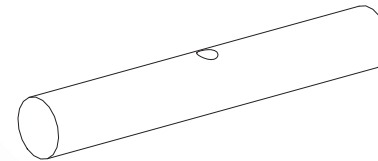

Section A-A

Steel rod D=12

Sheet

Drawn	Scale	Weight	Volume	Drawing number	Rev.
	1:1				



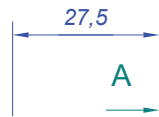
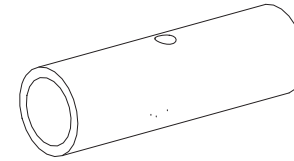
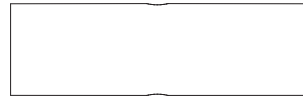

Ø 4

A

55

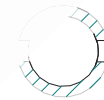

Section A-A

Steel round tube 17.2x2						
					Sheet	
Drawn	Scale	Weight	Volume			
	1:1					



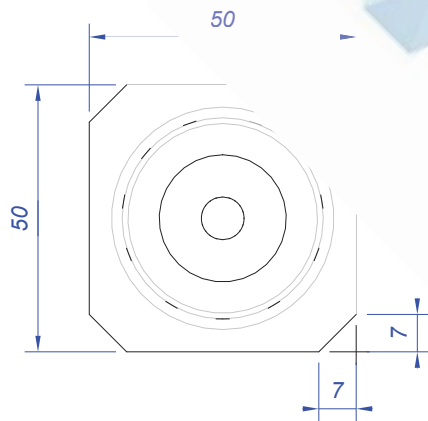
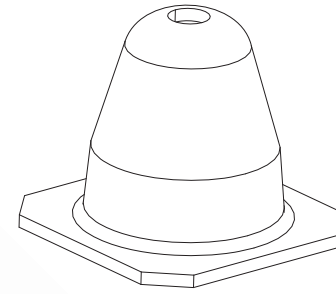
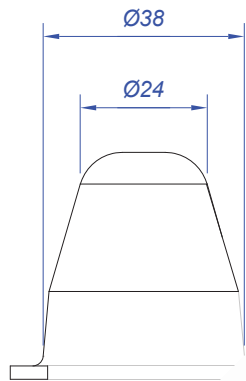

43

40

50

50

7

7

ECSP

Can be replaced after our validation with another standard stacking cone which permits a safe stacking with the stacking feet

Stacking cone

Stacking cone					Sheet	
Drawn	Scale	Weight	Volume			
	1:1					



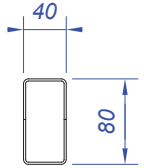
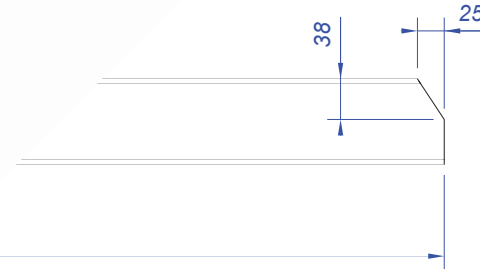
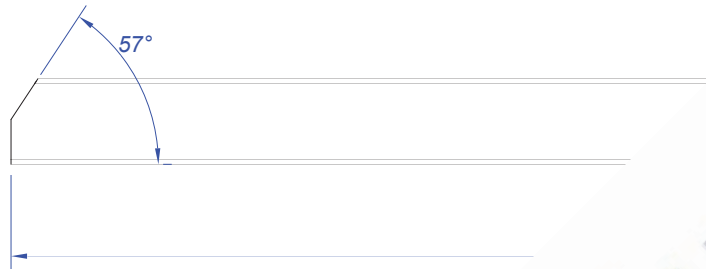

Steel tube 80x40x2					Sheet	
Drawn	Scale	Weight	Volume		Drawing number	Rev.
	1:5					





Steel sheet T=3					
					Sheet
Drawn	Scale	Weight	Volume		Rev.
	1:1				



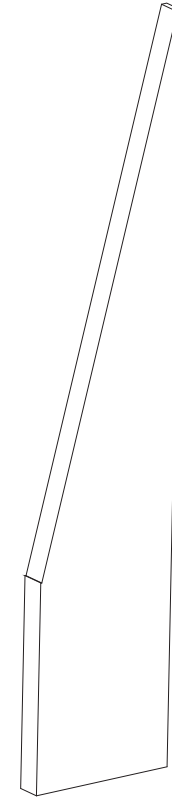
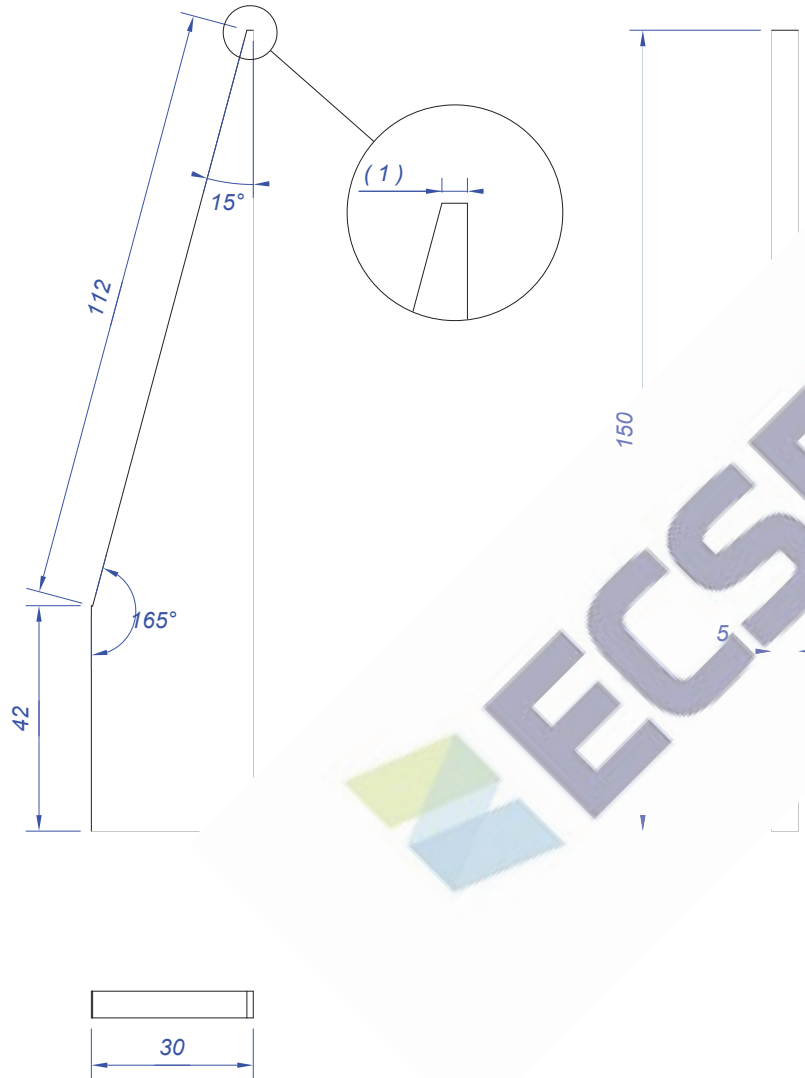

WECSP

Steel sheet T=5					
				Sheet	
Drawn	Weight	Scale			Rev.
	0,116	1:1			



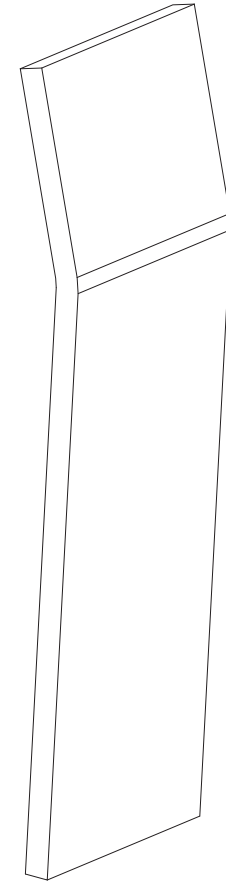
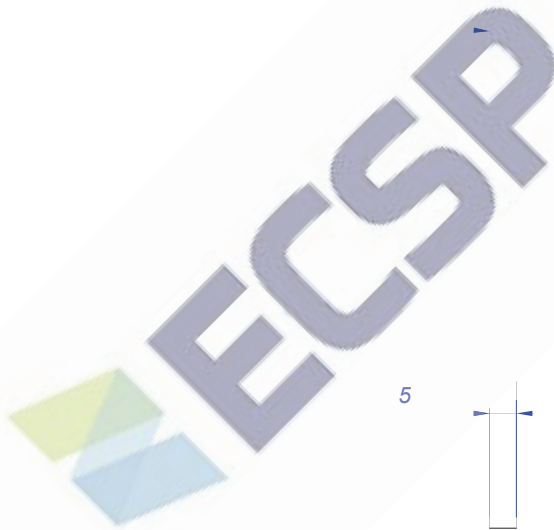
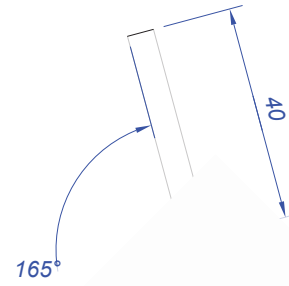
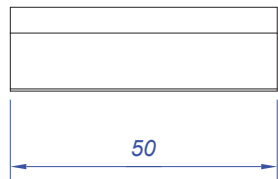
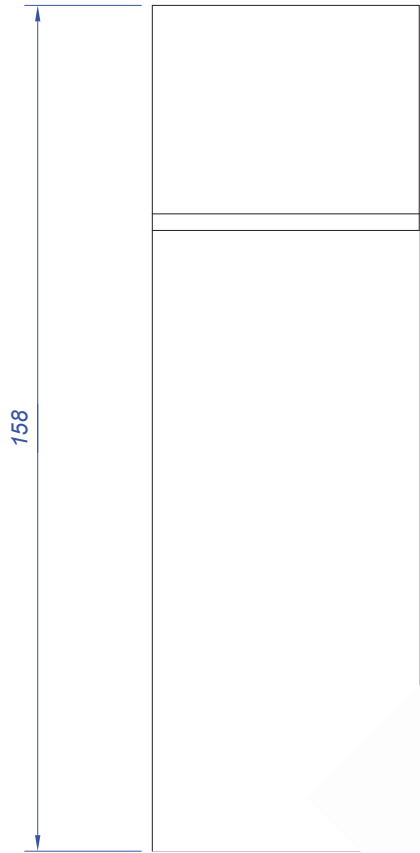

Steel sheet T=5					
				Sheet	
Drawn	Weight	Scale			Rev.
	0,312	1:1			

