

NOTICE D'INSTALLATION **F**

INSTALLATION INSTRUCTION **GB**

MANUALE D'INSTALLAZIONE **I**

MANUAL DE INSTALACIÓN **E**

AUFSTELLUNGSHANDBUCH **D**

(Etiquette plaque signalétique)

PHRT 7 / 16

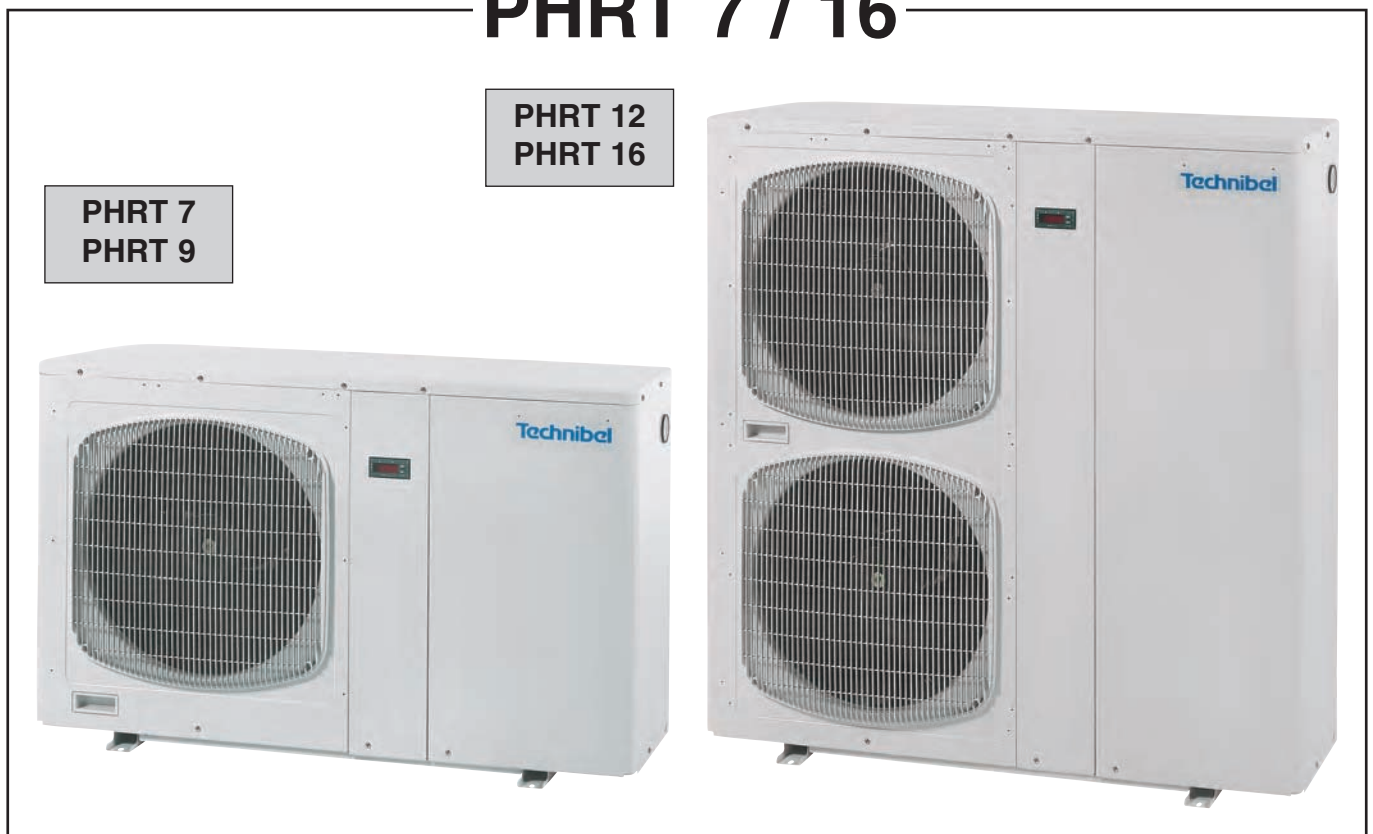

Pompe à chaleur avec équipement hydraulique - Fluide réfrigérant R 410 A

Heat pump with hydraulic equipment - R 410 A refrigerant

**Refrigeratore d'acqua in versione pompa di calore con sezione idronica incorporata
Fluido refrigerante R 410 A**

Bomba de calor con equipamiento hidráulico - Fluido refrigerante R 410 A

Wärmepumpe mit Hydraulikmodul Kältemittel R 410 A

MARKING

This product marked  conforms to the essential requirements of the Directives:

- Low voltage no. 2006/95/CE
- Electromagnetic Compatibility no. 89/336 EEC, modified 92/31 and 93/68 EEC.



GB

SUMMARY

1 - Generalities	2
2 - Presentation	3
3 - Installation	5
4 - Connections	5
5 - Operation of "ECH" electronic control	7
6 - Accessories	13
7 - Starting	15
8 - Maintenance instruction	16
9 - Troubleshooting	16
10 - Circulator curves	17
11 - Pressure curves	18
12 - Wiring diagrams	20

APPLIANCES FILLED WITH R 410 A

R 410 A

- R 410 A is a high-pressure refrigerant (+ 50% in relation to R 22 and R 407 C).
- The compressors approved for operation with this fluid are filled beforehand with polyalcohol oil.
Contrary to mineral oil, it is very hygroscopic: it absorbs the humidity of the ambient air very quickly. This can modify its lubricant properties and lead in time to the destruction of the compressor.

MAINTENANCE INSTRUCTIONS

- 1 - Never add oil to the appliance; the compressor is filled with polyalcohol oil, a special oil which cannot tolerate the presence of other oils.
- 2 - The instruments used for:
 - filling,
 - pressure measurements,
 - emptying under vacuum,
 - recovering the fluid,must be compatible and only used for the R 410 A fluid.
Note: the pressure taps of the refrigerating circuit are 5/16 SAE (1/2 - 20 - UNF)

- 3 - In the case of a new charge:
 - the charge **must** be undertaken in liquid phase,
 - use a balance and a dip pipe type R 410 A cylinder,
 - charge the weight of R 410 A as per the value indicated on the unit's identification plate (for "split systems", refer to the installation instructions as the charge must consider the length of the connecting lines).
- 4 - In case of leakage, do not complete the charge: recover the remaining refrigerant for recycling and perform a total charge.
Recovery, recycling or the destruction of the fluid must be done in compliance with the laws in force in the country concerned.
- 5 - If the refrigerant circuit is opened, you must:
 - avoid the entry of air into the circuit as much as possible,
 - replace or install a drier,
 - perform the "vacuum operation" at a minimum level of **0.3 mbar (static)**.

1 - GENERALITIES

1.1 - GENERAL SUPPLY CONDITIONS

- Generally speaking, the material is transported at the consignee's risk.
- The consignee must immediately provide the carrier with written reserves if he finds any damage caused during transport.

1.2 - RECOMMENDATIONS

- Prior to all servicing or other actions on the equipment, installation, commissioning, operation, or maintenance, the personnel in charge of these operations shall become familiar with the instructions and recommendations provided in the installation manual of the unit as well as the elements of the project's technical file.
- The personnel responsible for receiving the unit must conduct a visual inspection in order to identify all damage to which the unit may have been subjected during transport: refrigerating circuit, electrical cabinet, cassis and cabinet.
- The unit must be installed, started, maintained and repaired by qualified servicing personnel in compliance with the requirements of all directives, laws and regulations and in accordance with standard trade practices.
- During installation, troubleshooting and maintenance operations, the use of pipes as a step: under the stress, the pipe may rupture and the refrigerant may cause serious burns.

1.3 - VOLTAGE

- Before carrying out any operation, check that the voltage indicated on the unit corresponds to the mains voltage.

1.4 - USE OF EQUIPMENT

- This heat pump is intended for the air-conditioning of premises.

1.5 - OPERATING CONDITIONS

- Refer to the nominal conditions and operating limitations in the technical manual.

2 - PRESENTATION

2.1 - DESCRIPTION

- 1 - Sound-proofed hermetic compressor.
- 2 - Plate water heat exchanger.
- 3 - "Plate-Fin" air heat exchanger.
- 4 - Fan motor.
- 5 - Fan protection grille.
- 6 - Electrical box.
- 7 - Microprocessor control unit display keyboard.
- 8 - Circulating pump.

- 9 - Expansion tank.
- 10 - Safety valve.
- 11 - Pressure gauge.
- 12 - Water inlet connector.
- 13 - Water outlet connector.
- 14 - Filling / drainage of the water circuit.
- 15 - Air vent.
- 16 - Hole for connecting cables.

Materials:

- Copper piping.
- Painted sheet metal cabinet.
- Copper/aluminium air heat exchanger.
- Stainless steel water heat exchanger.
- Plastic grille.

PHRT 7
PHRT 9

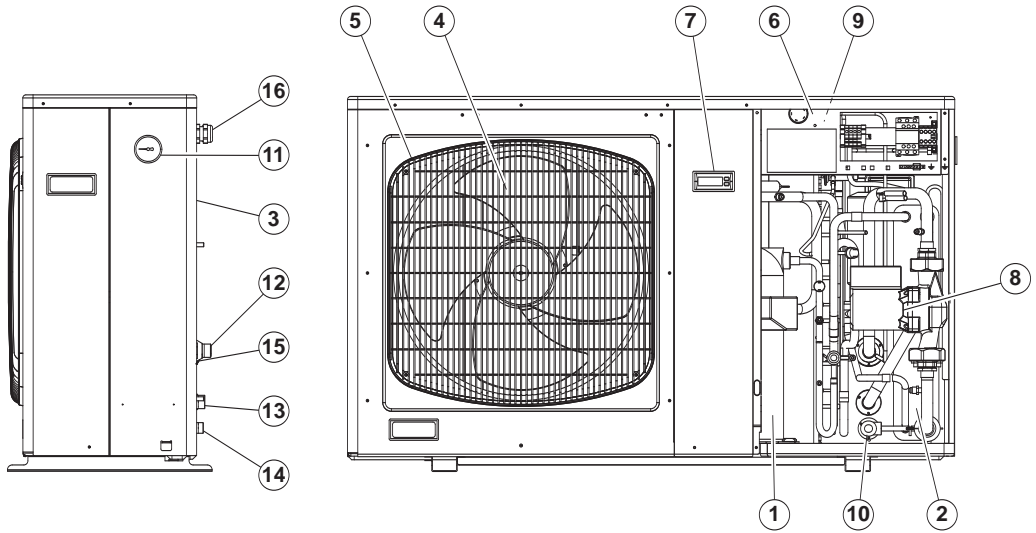

PHRT 12
PHRT 16

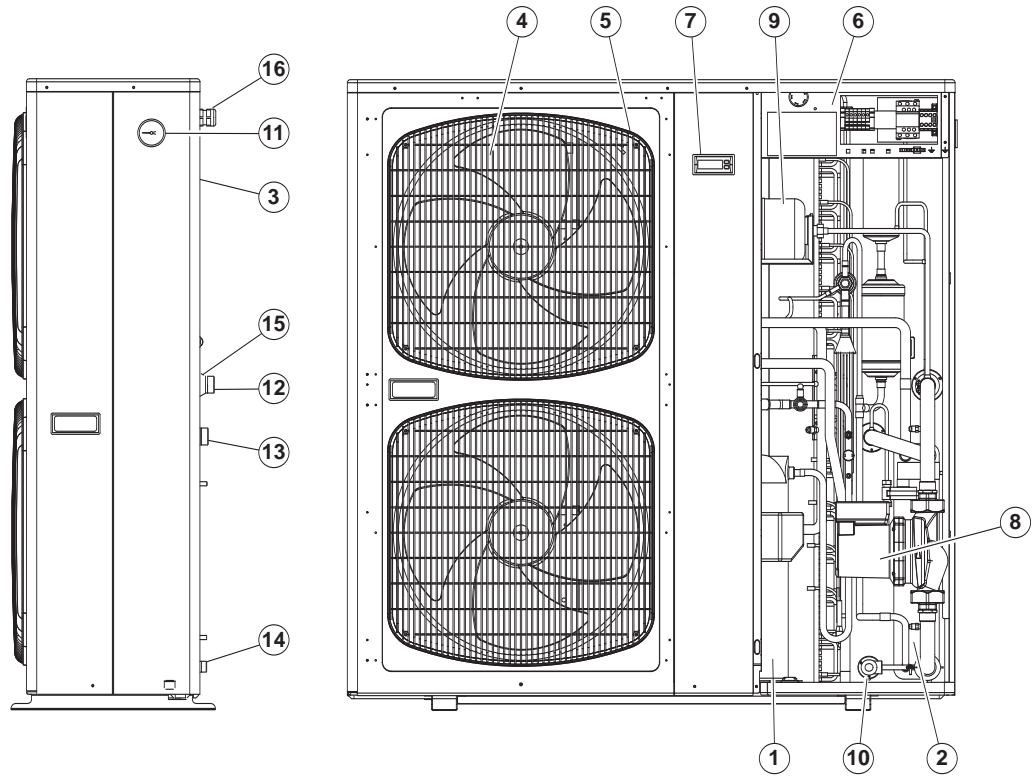

2.2 - DIMENSIONS AND WEIGHT

GB

	Weight (kg)
PHRT 7	98
PHRT 9	98

1	Water inlet connection 3/4" (male) with air vent valve
2	Water outlet connection 3/4" (male)
3	Water circuit fill/drain - 1/2" male
4	Holes for electric cables

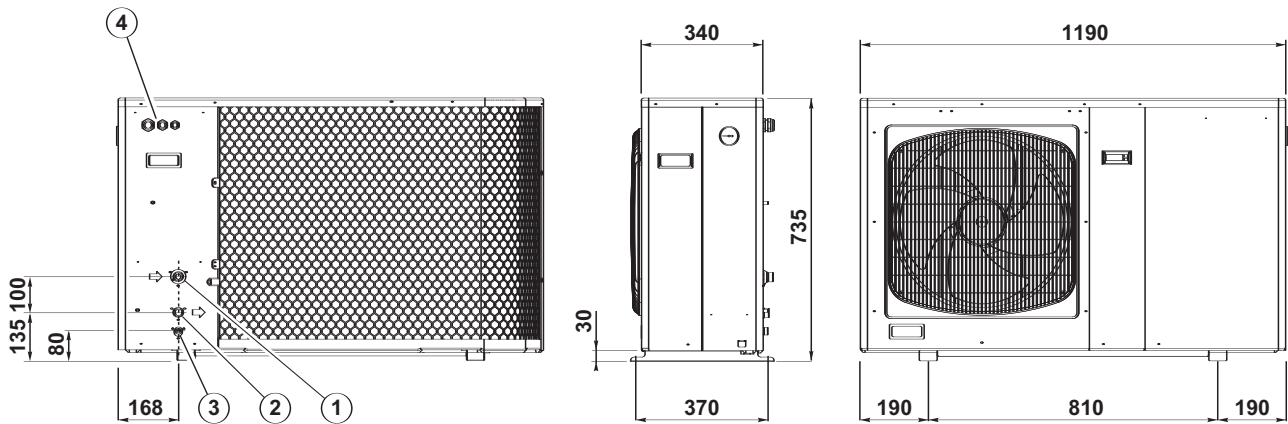

	Weight (kg)
PHRT 12	128
PHRT 16	133

1	Water inlet connection 1" (male) with air vent valve
2	Water outlet connection 1" (male)
3	Water circuit fill/drain - 1/2" male
4	Holes for electric cables

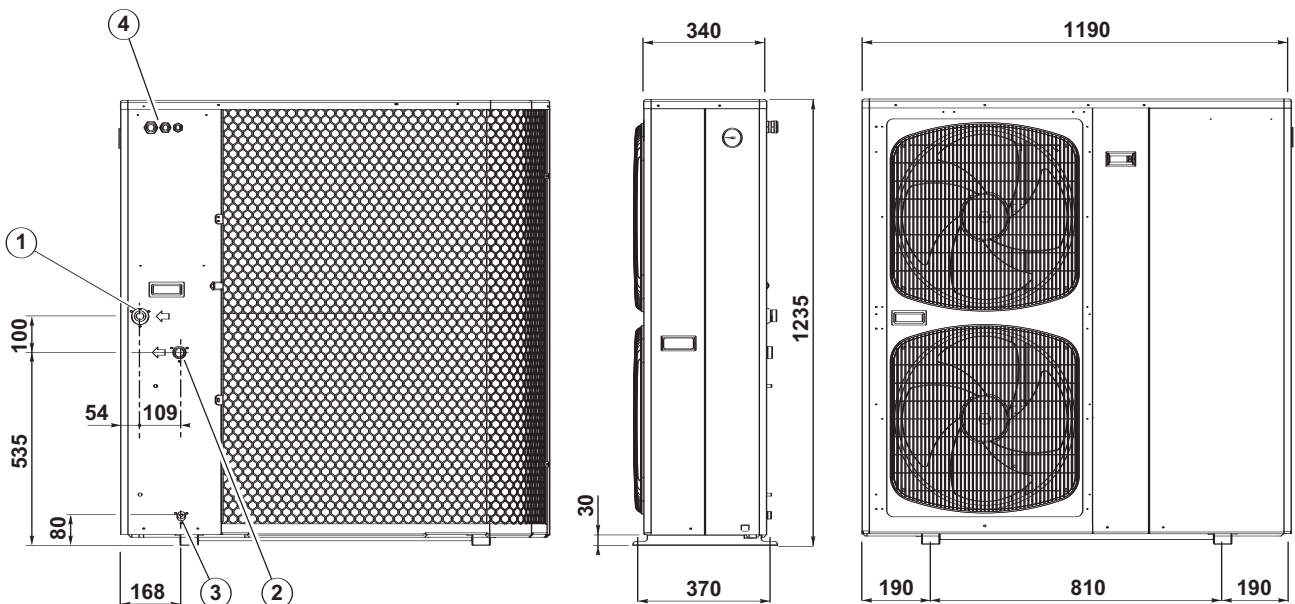

3 - INSTALLATION

- Protection index of the unit: IP 24.
- Select the location for the unit on the basis of the following criteria:
 - the unit must be installed outside,
 - the unit must not be installed near the following:
 - . sources of heat,
 - . combustible materials,
 - . return/air intake of an adjacent building.
 - it is necessary to make sure that the free space around the unit is provided (see the minimum dimensions on the drawing opposite),
 - installation must be simple and make maintenance work easy,
 - the unit must be fixed on a hard base and must be protected from risks of flooding,
 - the unit must be raised approximately 30 mm above the ground to facilitate the drainage of condensates from the tank and to prevent it from being encased in ice,
 - in the event where the condensates must be channeled (see below), the unit must be raised 100 mm above the ground by means of blocks,
 - use the anti-vibration mountings supplied, making sure that they are not compressed too much when the fastening screws are tightened,
 - the blown air must not be directed towards surrounding windows,
 - vibrations and noise must not be transmitted to a nearby building,
 - avoid:
 - . excessive exposure to salty air or sulphuric gas,
 - . the proximity of the extractor fan,
 - . projections of mud (next to a roadway or path, for example),
 - . areas where there is strong wind blowing against the unit's air exhaust.

DRAINAGE OF CONDENSATES

- If necessary, use the accessory part supplied to connect the condensate drainage tube.
- The base has 2 drainage holes (one on each side).
- For condensate drainage, place the splined elbow in one of the holes, depending on the unit's inclination or the preferred side, and plug the other hole with the plastic cover.
- In this case, the tank and the drain line must be protected against freezing risks.

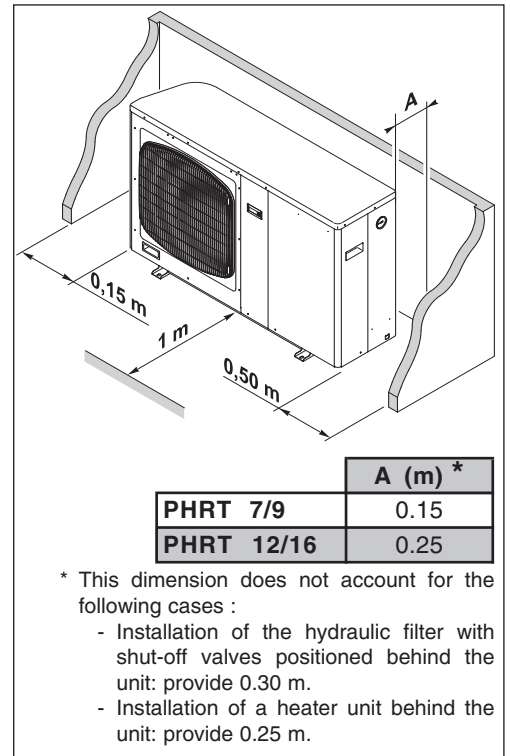

GB

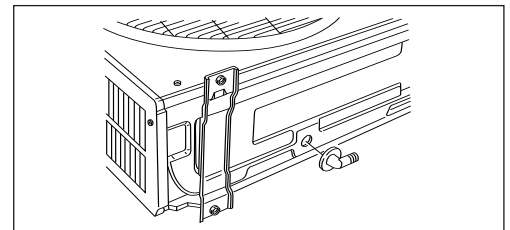

4 - CONNECTIONS

4.1 - DISASSEMBLY

- To remove side panel **A** :
 - remove the 3 retaining screws **B**,
 - lower the panel **(1)** using the handle **C**,
 - pull the lower part of the panel toward you **(2)**.

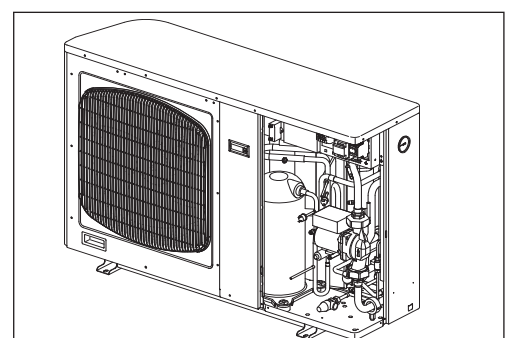
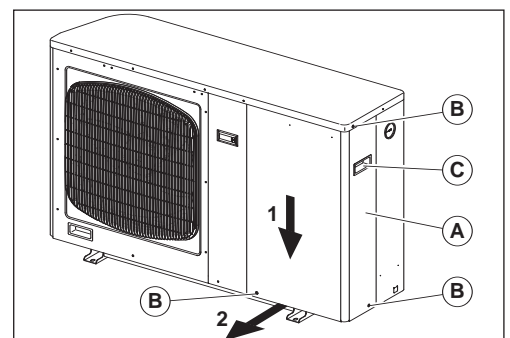

4.2 - HYDRAULIC CONNECTION

- Connect the water pipes to the corresponding connections. See Ø and position on page 4.
- Install the hydraulic filter (supplied) on the water intake. Connect it using 2 isolation valves for cleaning purposes.
- Install a shut-off valve if a fill/drainage connection is used.

NOTE:

"Water connection hose" accessories may be used (refer to the accessories paragraph).

4.3 - ELECTRICAL CONNECTION

4.3.1 - GENERAL:

- The acceptable voltage variation is: ± 10% during operation.
- The electrical connection conduits must be fixed.
- Use the cable clamps at the rear of the unit and route the wires under the electric panel, at the level of the terminal strips.
- Class 1 unit.
- The electrical installation must comply with the standards and regulations applicable where the unit is being installed (in particular NF C 15-100 ≈ IEC 364).

4.3.2 - POWER SUPPLY

- The power supply must come from an isolation and electric protection device (not supplied) in accordance with existing regulations.
- The installation must be protected by a **double-pole circuit-breaker** (not included). See the intensity ratings table below.

Note:

The unit is designed to be connected to a power supply having a TT neutral regime (neutral to ground) or TN.S regime (to neutral) as per NF C 15-100.

POWER SUPPLY CABLE

- **Section 230V/1/50Hz** : 3 G 4 mm² for **PHRT 7, 9 and 12**.
- **Section 400V/3N/50Hz** : 5 G 2.5 mm² for **PHRT 9, 12 and 16**.
- The sections are given as an indication only. They have to be verified and adapted, if necessary, according to the installation conditions and the standards in force.
- Make the electrical connections to the terminal board as per the electrical diagrams.

CURRENT

		PHRT 7 230/1/50	PHRT 9 230/1/50	PHRT 9 400/3N/50	PHRT 12 230/1/50	PHRT 12 400/3N/50	PHRT 16 400/3N/50
Nominal current	A	12.8	15	6.1	16.7	7.5	10.2
Max. current	A	16	18.2	7.5	21.3	9	12.7
Starting current	A	40	33	39	34	56	63
Protection rating	A	20	25	10	25	12	16

CAUTION:

In the case of a three-phase power supply, prior to commissioning the unit, make sure that the phase rotation order is correct. If the rotation order is not respected, the phase-sequence controller restricts the unit from operating.

To fix this, simply invert the 2 phases.

4.3.3 - CONTROL BY EXTERNAL CONTACTS

- The machine is factory-wired for heating mode operation. The unit can be controlled remotely by connecting two good-quality external potential-free contacts (not supplied) :
 - 1 for the remote On/Stand-by signal (contact closed = operation authorized, contact open = stand-by),
 - 1 for change-over of the operating mode (contact closed = heating mode, contact open = cooling mode).
- The On/Stand-by signal is connected to terminals 1 and 2 of the PCB located in the switch box (remove the existing bridge - see diagram).
- The mode change-over signal is connected to terminals 3 and 4 of the PCB (remove the existing bridge - see diagram).
- The wiring of these contacts must not be routed near power cables in order to avoid electromagnetic disturbances.
- Use shielded cable with twisted pairs (shielding grounded on generator side).
- Max. connection cable length: 100 m.
- Minimum wire size: 0.5 mm².

CAUTION:

Mode changes (heating/cooling) are to be performed with the unit shutdown.

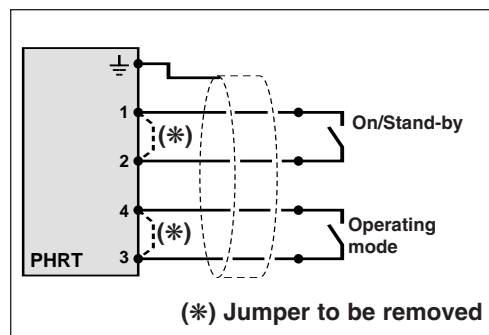

4.3.4 - REMOTE CONTROL

- See paragraph "accessories".

4.3.5 - MISCELLANEOUS

• **Alarm transfer:**

Potential-free changeover contact (2A - 250 VAC max.) available on the unit's terminal strip (terminals 5 (common), 6 and 7 of the printed circuit) for remote signaling. See schematic.

- **In case of alarm :**

- contact open between terminals 5 and 6,
- contact closed between terminals 5 and 7.

5 - OPERATION OF "ECH" ELECTRONIC CONTROL

- See the wiring diagrams at the back of the manual.

5.1 - DELIVERY STATE

- The control unit is supplied fitted in the machine and factory pre-set.
- All the connections are made except those concerning the available signals or the options.

5.2 - PRINCIPLE

- The microprocessor controls the operation of the machine and of the associated alarms.

It continuously compares the water temperature measured by the probe **SD1** and the setpoint temperature value entered via the keyboard.

Each operating request produced by the control unit is indicated by the light **(6)** (see below).

This light flashes if a safety delay is in progress. It stays on when the compressor is operating.

- The **control probe SD1** is located on the **water inlet** in the factory.
- The controller is connected on a printed circuit board on which the inputs and outputs are connected.

On this board :

- 12 V supply transformer,
- the alarm report relay,
- the 230 V circuit fuse (4 A - 250 V - 5x20 - fast - breaking capacity: 1.5 kA).

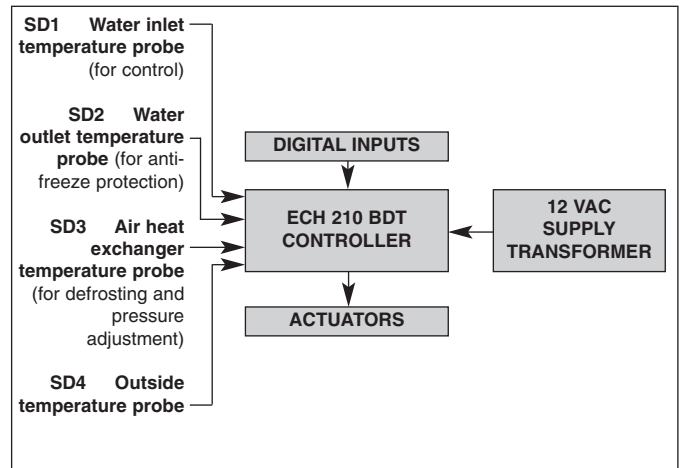

5.3 - PRESENTATION

5.3.1 - DISPLAY KEYBOARD

(1) Key for:

- Local On / Off control,
- access to parameters (in combination with button (2)),
- alarm clearance,
- hour counter reset.

(2) Key for:

- Local operating mode selection (heating/cooling) (the function is activated by special parameterisation, see paragraph 5.8),
- access to parameters (in combination with button (1)).

(3) LED display.

(4) Cooling mode indicator.

(5) Heating mode indicator.

(6) Compressor on indicator.

(7) Defrosting indicator.

(8) Anti-freeze on indicator.

(9) Decimal point: if illuminated when the operating time is displayed, the value must be multiplied by 100.

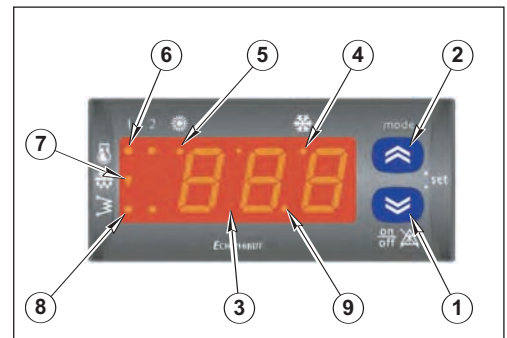

5.3.2 - CTN TYPE TEMPERATURE PROBE

- 10 kΩ at 25° C.

Temperature (°C)	Ohmic value (Ohm)
-20	67 740
-10	42 450
0	27 280
10	17 960
20	12 090
25	10 000
30	8 313
40	5 820
50	4 161
60	3 021
70	2 229

5.4 - OPERATING MODES

- The machine is wired in the factory to operate in heating mode.
- The operating mode changeover (heating / cooling) may be controlled remotely by means of an external contact (**not supplied**) connected to the unit (see details in paragraph 4.3.3):
 - contact open = cooling
 - contact closed = heating.

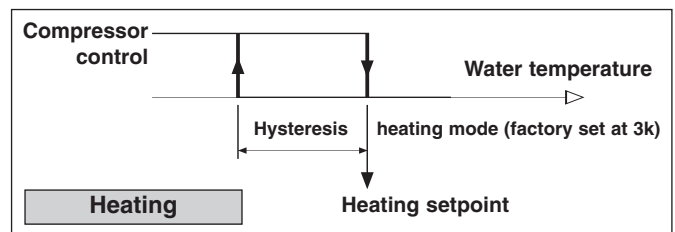
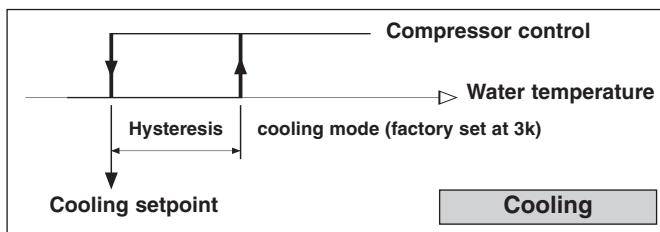

5.5 - STARTING

The unit is factory configured for remote control by contacts (see other possibilities in paragraph 4.3.3).

- **Initial condition:**
 - machine hydraulically and electrically connected ready to operate,
 - operating mode remote changeover switch is in required position (heating or cooling),
 - the remote stand-by contact is open (= stand-by).
- **Turn the installation on:**
 - the display comes on and shows the water temperature (read by the control probe **SD1**). The mode indicator lamps (4) and (5) flash to signal remote stand-by,
 - the unit's circulating pump starts.
- **To start the unit:**
 - close the remote stand-by contact (not supplied) if connected (see paragraph 4.3.3)
 - The indicator lamp corresponding to the selected mode lights up:
 - indicator lamp (4): Cooling,
 - indicator lamp (5): Heating.
 - The compressor "ON" indicator light (6) comes on if necessary (see diagram paragraph 5.4). If the light flashes, it means that the compressor is starting required but that a safety delay is in progress. This light stays on when the compressor has started.
- **To stop the unit:**
 - open the remote stand-by contact,
 - the compressor operation indicator lamp (6) goes out and the operating mode indicator lamps (4) and (5) flash,
 - the unit's circulating pump remains in operation.
- **Complete stop:**
 - the unit can be completely stopped with the circulating pump shut-down by pressing and holding the **ON/OFF** button (1) for 2 seconds. The display unit goes blank, only the decimal indicator lamp (9) remains illuminated. This shut-down takes priority.

Note:

Shut-down of the circulating pump is delayed 1 minute after the compressor stops.

CAUTION:

we recommended that the unit be shut down a few minutes before changing the operating mode (heating <---> cooling).

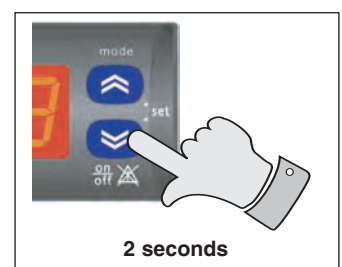

5.6 - PARAMETERS - DISPLAYING AND ADJUSTING

5.6.1 - GENERAL

- Parameter access is structured within a multi-level menu, see the diagram below. Simultaneously pressing the "ON/OFF" (1) and "Mode" (2) buttons for a brief moment (less than 2 seconds) gives access to the next level. Simultaneously pressing for a long moment (longer than 2 seconds) turns you to the previous level.

GB

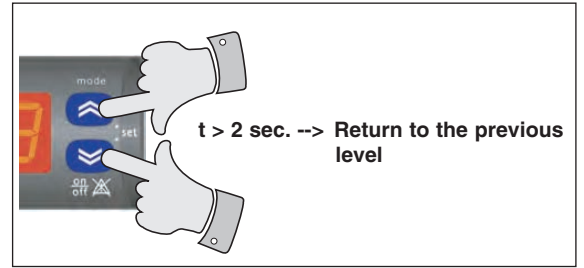
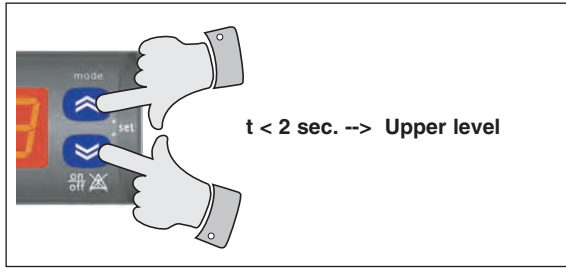

- Button (1) or button (2) is used to scroll through the entries ("Label") within the same level or to increase or decrease a parameter value.

5.6.2 - PARAMETER ACCESS DIAGRAM

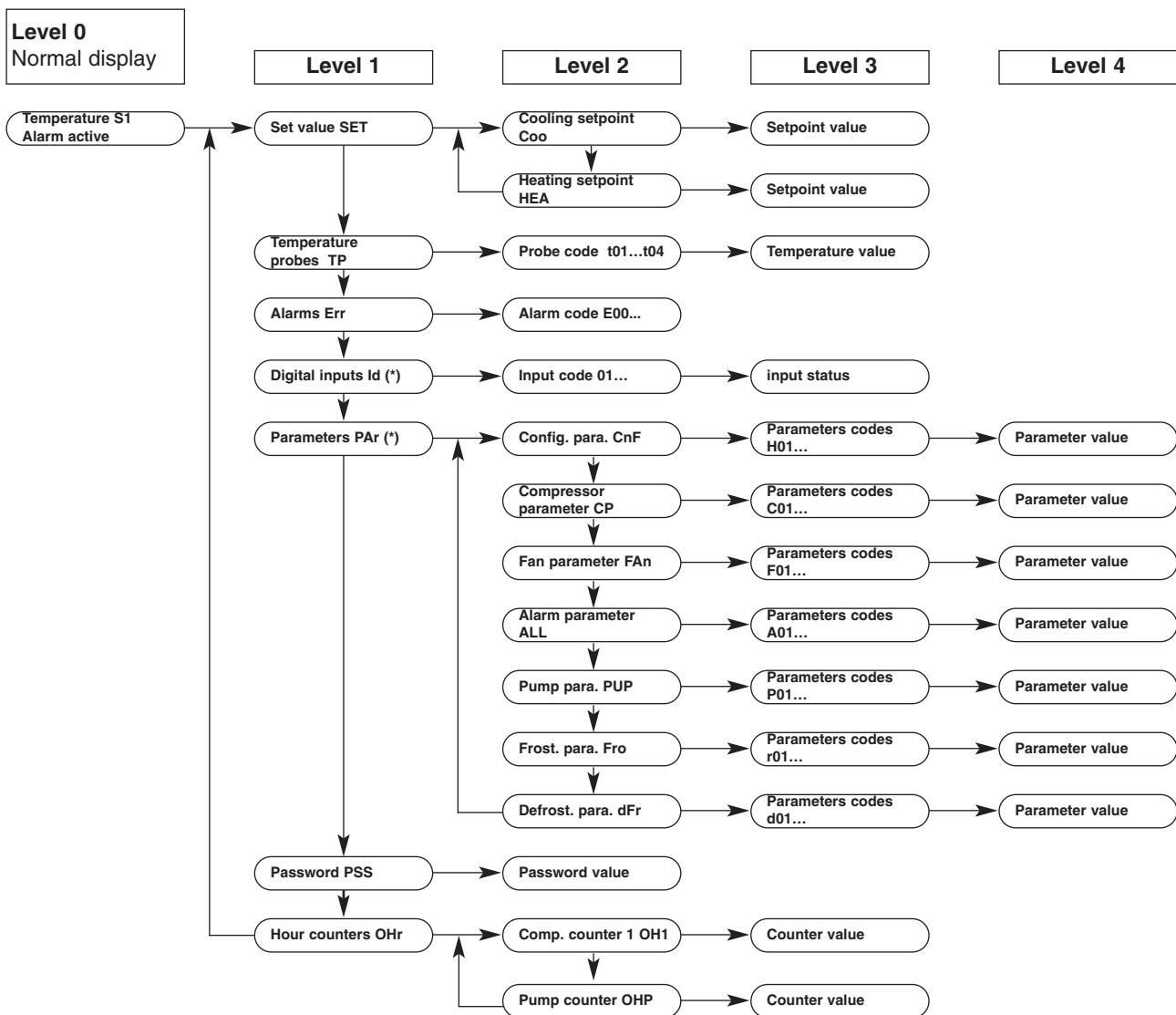

(*) Accessible to qualified personnel only after entering the password (PSS).

Note 1:

Indicator lamps (6), (7), (8) flash when levels 1 and above are accessed.

Note 2:

The normal display (level 0) returns automatically after 5 minutes if no buttons are pressed.

5.6.3 - SETPOINT ADJUSTMENT

- Simultaneously press buttons (1) and (2) for at least 2 seconds, "SET" is displayed.
- Press the 2 buttons again, "Coo" is displayed. Using button (1) or (2), display either "HEA" or "Coo" corresponding to the heating setpoint ("HEA") or cooling setpoint ("Coo").
- Simultaneously press the 2 buttons again for 2 seconds. The setpoint value appears. If needed, modify the value with the buttons.
- Press the 2 buttons simultaneously to validate the setpoint.
- Return to the normal display by simultaneously pressing the 2 buttons for more than 2 seconds.

Reminder: control on the installation return temperature.

Note:

For terminal unit and boiler overhaul applications, the configuration and parameterisation of each machine are factory-set for optimum operation.

Code	Parameters	Settings for terminal units and boiler overhaul applications	Adjustment range
HEA	Heating set point	48° C	20 to 50° C
Coo	Cooling set point	12° C	10 to 30° C

5.6.4 - DISPLAY OF TEMPERATURES, ALARMS, AND HOUR COUNTERS

Accessible directly via the menu, see diagram 5.6.2.

- Temperatures "TP" :
Displays the values indicated by each temperature probe.
- Alarms "Err" :
Displays the list of all current alarms (scroll through the alarm messages with buttons (1) and/or (2)).
- Hour counters "Ohr" :
Displays the operating time of the compressor ("OH1") and the circulating pump ("OHP"). The counter can be reset by a long press (> 2 seconds) on button (1) when the counter value is displayed.

5.6.5 - ACCESS TO THE TECHNICAL PARAMETERS "PAR"

For qualified personnel after entering the password "PSS". Any incorrect adjustment may lead to serious malfunctions.

- Go to the "PSS" section in the menu. Briefly and simultaneously press buttons (1) and (2). The "---" message appears. Enter the password using buttons (1) and (2) and validate it by simultaneously pressing buttons (1) and (2). It is now possible to enter the parameters section "PAR".

CAUTION:

After modifying one or more technical parameters, the controller must be turned off then back on again to reset it with its new parameters.

5.7 - ALARMS

- When an alarm occurs:
 - the alarm report is activated,
 - the corresponding code flashes on the display unit. See table,
 - the unit stops if necessary (see table below).
- Remedy the fault.

IMPORTANT NOTE:

All work must be carried out by qualified, experienced personnel.

- The alarms are normally reset automatically.
- Caution: the alarms:
 - HP,
 - LP (low pressure),
 - Anti-freeze,
 - Water flow rate,

have an event counter that shifts to **manual** reset if the alarm occurs several times during the last hour.

- The "refrigerating circuit" alarm is reset manually.
- The alarms are reset by briefly pressing the "ON/OFF" button (1).
- When the alarm is cleared :
 - the alarm report is de-activated,
 - the display reverts to normal (not flashing),
 - the machine can re-start (if it was stopped).
- **Special features of the alarm relay :**
 - the potential-free change-over contact (2 A - 230 VAC max.), on the wiring board's terminal strip, originates from the relay located on this board,
 - the relay is actuated in the absence of an alarm (contacts: 5/6 closed and 5/7 open),
 - in the case of alarm or power supply loss, the relay is released (contacts: 5/6 open and 5/7 closed).

SUMMARY TABLE OF ALARMS

Alarm	Code	Inhibition delay	Compressor stop	Fan stop	Circulating pump shut-down	Remarks
Fault on probe 1	E40		X	X		
Fault on probe 2	E06		X	X		
Fault on probe 3	E07		X	X		
Fault on probe 4	E42		X	X		Forced circulating pump operation
H.P.	E01		X			
B.P. (low pressure)	E02	30" at start-up	X	X		
Anti-freeze (water heat exchanger)	E05	60"	X	X		From probe SD2 (water outlet). Threshold : 4° C
Water flow rate	E41	10" in operation 30" at start-up	X	X	X If passage reset manual	
Refrigeration circuit (*)	E44	120" at start-up + 120" in operation	X	X		Manual reset. Inactive in anti-freeze phase.
Max. water temperature	E46	30"	X			From probe SD1 (water inlet). Threshold: 70° C adjustable (A25)
Configuration error	E45		X	X	X	

(*) The refrigeration circuit alarm is activated if the temperature difference between the water inlet and outlet (after a few minutes of compressor operation) is insufficient (refrigerant charge, three-phase compressor turning "backwards", inversion valve blocked...).

5.8 - SPECIAL OPERATING FEATURES

• Reduction of water volume:

- the controller uses a self-adapting algorithm that analyses the compressor's operating time and can indicate deviations of the current set point (and the corresponding hysteresis) in case of too short operating times (in order to extend the operating times),
- for special applications, in which case the dimensioning of the unit and the circuit are carefully designed, this function can be deactivated. To do this, set the parameter **C08** to **0** in the "**CP**" section of the parameterization menu.

• Defrosting (in heating mode only):

- if the temperature detected by probe **SD3** drops below the frosting temperature (dependent of the outside temperature), a time counter is activated. This counter records the operating time in icing conditions. This status is indicated by the flashing frosting indicator lamp (7),
- after an accumulated operating time of 30 minutes, a defrosting operation is launched (inversion of the refrigerating cycle and shut-down of the fan) until the temperature detected by probe **SD3** rises above the end of frosting temperature threshold. The defrosting phase is indicated by the (steady) illumination of indicator lamp (7).

Note:

The ventilation can restart after defrosting is completed to prevent excessive pressure build-up.

For special climatic conditions, the factory-set time counter value of 30 minutes can be adjusted. To do this, modify parameter **d03** in the defrosting section "**dFr**".

• Condensation pressure control:

- the ECH controller is equipped with a variable voltage regulator for the fan's power supply,
- based on temperature information (captured by probe **SD3** placed on the condenser), the controller varies the supply voltage of the electric fan according to the diagram opposite,
- **this system is active in cooling mode.**

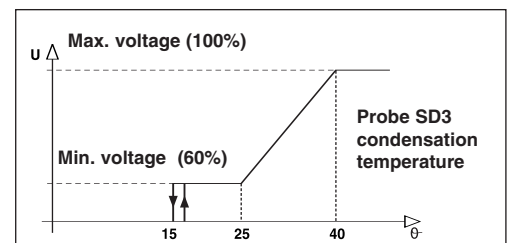

• Circulating pump control :

- the pump is actuated when the unit operating or in **stand-by** mode,
- the pump is stopped when the unit is completely **OFF**. The shut-down of the pump is delayed 1 minute after the compressor stops. An anti-freeze device forces pump operation if the outside temperature (probe **SD4**) drops below 0°C,
- an "anti-sticking" device forces pump operation (if stopped) for 3 seconds every 24 hours.

- **Condensate tank heating cord control:**

(Accessory, see installation in paragraph 6.2).

- actuated if the outside temperature (probe **SD4**) drops below 0°C (regardless the unit's operating mode). The "heating element" indicator light (**8**) illuminates.

- **Operating mode selection:**

- the controller is factory configured to control the unit by 3 outside contacts:
 - On / Stand-by ("**stand-by**"),
 - Heating / Cooling.
- in stand-by mode, the circulating pump continues to function.

Note:

It is possible to shut the unit down completely (circulating pump stopped) by pressing the **ON/OFF** button (**1**).

- this configuration is adapted to system applications,

- for other applications, the following configurations are possible by modifying the parameterization:

a) Complete shut-down ("**OFF**") by remote contact (instead of "**stand-by**").

In the "**CnF**" configuration section, change the parameter **H20** from **7** (remote stand-by) to **4** (remote **OFF**). In the case of **remove "OFF"** complete shut-down, the display is off. Only the decimal indicator lamp **flashes**.

b) Selection of the heating / cooling mode using the display unit's keys.

In the "**CnF**" configuration section, change the parameter **H27** from **1** (selection by remote contact) to **0** (selection by keypad).

This configuration is chosen in the case where the remote display unit **70250055** is used (Accessory, see installation in paragraph 6.4) to control the unit, for example.

The operating mode is thus selected by successively pressing the "**mode**" button (**2**) according to the following sequence:

--> **stand-by** --> cooling --> heating --> stand-by --

The stand-by mode is indicated by the extinction of the heating and cooling mode indicator lamps.

- **Pre-ventilation:**

- generally speaking, in order to condition the air heat exchanger, the fan always starts at full speed a few seconds before the compressor.

- **Anti short-cycle time delays:**

- the compressor control features a time delay system in order to respect:
 - a maximum number of starts per hour (10),
 - a minimum stop time.

- **Cycle inversion valve:**

- The valve is actuated in cooling mode.

- **Control hysteresis:**

- See the operating diagrams in paragraph 5.4.
- The hysteresis in both heating and cooling modes are factory set at 3k. They can be modified. To do this, change parameters **C03** (cooling hysteresis) and/or **C04** (heating hysteresis) in the compressor section "**CP**".

6 - ACCESSORIES

6.1 - WATER CONNECTION HOSES

- Length 1 m, insulated, female:
 - Ø 3/4" code **70600054** for **PHRT 7** and **9**,
 - Ø 1" code **70600055** for **PHRT 12** and **16**.

6.2 - CONDENSATE TANK HEATING CORD KIT

- Code **70200055**.
- This accessory is recommended for units installed in where defrosting is frequent.
- Remove the fan's protective grille (4 screws **A**).

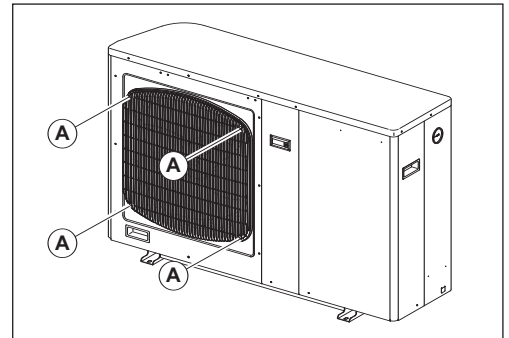

- Remove the fan blade (nut **B**).

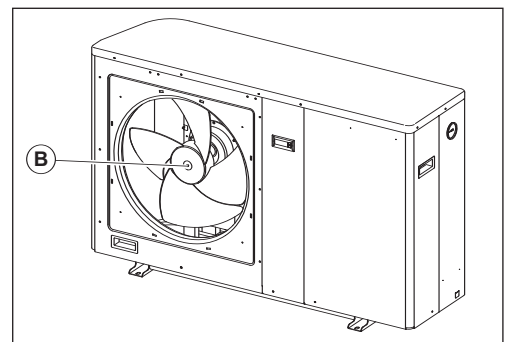

- Place the heating element in the bottom of the tank, as close as possible to the fin tube exchanger.

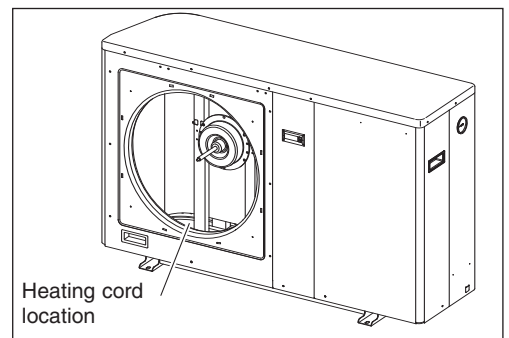

- Position the isolated end on the left side and along the exchanger to the back of the separating panel. Form a loop and return along the separating panel.
- Use the aluminium adhesive strip to hold the heating cord in place, or as required, metal clips welded in the tank.
- Pass the end of the heating cord through the grommet in the separating panel with the fan wires.

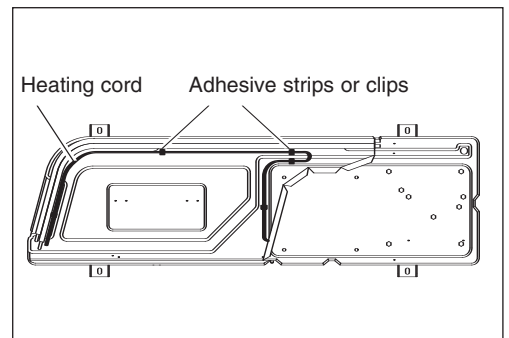

- Connect the two wires on the printed circuit board between terminals 47 and 48.

Note:



The wire heats up over a length of 1.5 m.

Be sure not to place the heating portion in contact with the wires.

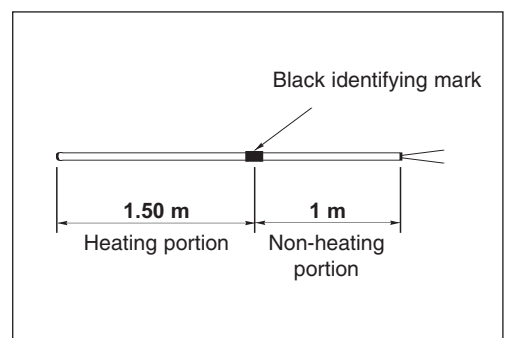
Make sure that the fan blade cannot come into contact with the heating element.



6.3 - REMOTE CONTROL

- Code **70250055**.
- The functions and display are exactly the same as those on controller.
- The only difference concerns the buttons  and  which are separated by the “ON/OFF” and “Mode” buttons.
- Reminder: the parameters are accessed by simultaneously pressing the “ON/OFF” and “Mode” buttons.
- **The controller is designed to be installed inside sheltered rooms.**



- Connection :
 - the control is delivered with a connecting it to the “ECH” controller,
 - to extend the link, max. length. : 100 meters, use twisted pair shielded cable with a cross section of at least 0.5 mm² (shielding of the ground on unit side).

CAUTION :

Do not route this cable near power cables.

The operation must take performed with the unit's power supply off and locked out.

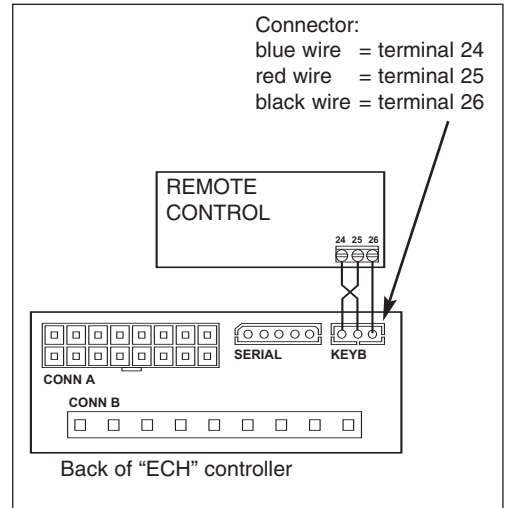

6.4 - RS 485 COMMUNICATION INTERFACE (MODBUS protocol)

- Code **70250056**.
- After removing the side panel, also remove the front panel **A** (remove the three retaining screws **B** and pull the panel downwards).
- Secure the communication interface **C** on the left-hand side of the electric panel.
- Connect the cable (supplied) between the communication interface **C** and the controller **D**.
- Connect the module's 230 VAC power supply in the following manner with the black and blue wires delivered with the accessory.

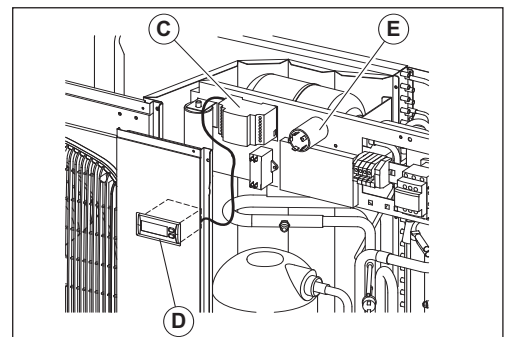
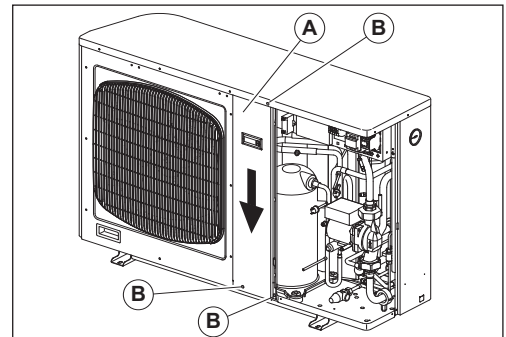

- Connection of the communication bus and protocol detail: refer to the corresponding technical file.

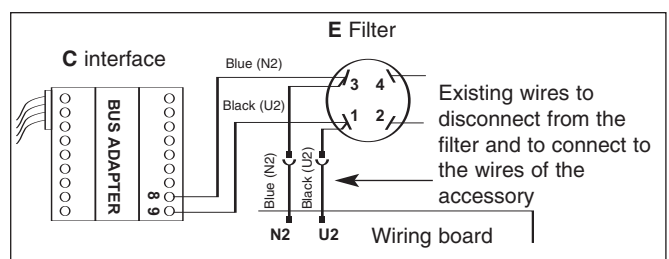

7 - STARTING

IMPORTANT NOTE

Before carrying out any work on the machine, make sure that it is switched off and that access to it is prevented.
Any work must be carried out by personnel qualified and authorised to work on this type of machine.

GB

7.1 - CHECK

- That hydraulic connections are properly tight and that the hydraulic circuit functions correctly:
 - purge of circuits,
 - position of valves,
 - hydraulic pressure (1.5 to 3 bar).
- That there are no leaks.
- That the machine is stable.
- That the power cables are well fixed to their connection terminals. Terminals that are poorly tightened may cause overheating and malfunctions.
- That the electric cables are well insulated from any sections of sheet metal or metal parts which could damage them.
- That probe, control and power cables are properly separated.
- That the machine is earthed.
- That there are neither tools nor other foreign objects in the units.

7.2 - STARTING-UP THE UNIT

- Power up the unit.
- Turn the water on.
- Start the appliance (see paragraph 5).

CAUTION:

On three-phase units, make sure that the phase rotation order is correct. If the rotation order is not respected, the compressor will turn backwards (and make an abnormal noise). To fix this, simply invert the 2 phases.

7.3 - CHECKS TO BE MADE

- Water flow-rate.
- The generator is equipped with 1/4 SAE pressure taps at the circulator inlet and outlet, to enable the pressure drop to be measured using a hydraulic pressure gauge. Use the circulator curves in paragraph 10 to find the water flow rate.

Note:

The generator's water output must be ensured at all times (particular attention should be paid in the case of control of the terminal units on 2-way valve).

- Hydraulic circuit pressures.
- Cooling circuit pressures.
- Control system operation.

IMPORTANT:

If antifreeze is added (monopropylene glycol), a minimum rate of 15% to 20% is needed to avoid any risk of corrosion.

- The LP pressure switch cuts at 0.5 bar.
- The HP pressure switch cuts at 42 bar.

8 - MAINTENANCE INSTRUCTIONS

IMPORTANT NOTE

- Before carrying out any work on the machine, make sure that it is switched off and that access to it is prevented.
- Also check the discharge of the compressor capacitor for the single-phase voltages.
- Any work must be carried out by personnel qualified and authorised to work on this type of machine.
- Prior to all maintenance and servicing on the refrigerating circuit, one must first shut down the unit then wait a few minutes before installing temperature or pressure sensors. Certain equipment, such as the compressor and piping, may reach temperatures above 100°C and high pressures may lead to serious burns.

8.1 - MAINTENANCE

All equipment must be properly maintained in order to provide optimum performance over time. Faulty maintenance can result in the cancellation of the product guaranty. Depending on the products, maintenance operations consist in the cleaning of filters (air, water), internal and external exchangers, casings, and the cleaning and protection of condensate tanks. Treating odours and the disinfection of room surfaces and volumes also contributes to the cleanliness of the air breathed by users.

- Carry out the following operations at least once a year (the frequency depends on the installation and operating conditions):
 - check for leaks on the refrigerating circuit,
 - check for traces of corrosion or oil stains around the refrigerating components,
 - inspect the composition and the condition of the coolant and check that it does not contain traces of refrigerating fluid,
 - cleaning the exchangers,
 - checking the wear parts,
 - checking the operating instructions and points,
 - check the safety devices: particularly check that the high and low-pressure controllers are properly connected on the refrigerating circuit and that they disengage the electrical circuit if triggered,
 - de-dusting the electrical equipment cabinet,
 - checking that the electrical connections are secure,
 - checking the earth connection,
 - check the hydraulic circuit (clean the filter, water quality, etc...).

8.2 - GENERATOR SHUT-DOWN DURING WINTER

- 2 possibilities:
 - 1) Drain the unit and disconnect the power supply.
 - 2) Unit full of water and power on: as the unit is equipped with an antifreeze device which actuates the water circulating pump when the temperature drops below zero, it is imperative to ensure that the water can circulate within the unit.

9 - TROUBLESHOOTING

- All maintenance and servicing operations on the refrigerating circuit must be conducted in accordance with standard trade practices and safety rules: recovery of the refrigerant, inert shielded (nitrogen) brazing, etc...
- All brazing operations must be conducted by qualified welders.
- For equipment loaded with R 410 A, refer to the specific instructions at the beginning of the installation manual.
- This unit is equipped with pressurized equipment, for example piping.
Use only genuine parts listed in the spare parts list for replacing defective refrigeration components.
- Pipes may only be replaced by copper tubing in compliance with standard NF EN 12735-1.
- Leak detection, in the case of pressure testing:
 - Never use oxygen or dry air, as the risk of fire or explosion is present.
 - Use dehydrated nitrogen or a nitrogen and refrigerant mix indicated on the manufacturer's plate.
 - The test pressure, low and high pressure, must not exceed 20 bar and 15 bar in the case where the unit is equipped with the pressure gauge option.
- For high pressure circuit pipes made with copper tubing having a $\varnothing =$ or $> 1\frac{5}{8}$, the supplier will be requested to submit a certificate § 2.1 in accordance with standard NF EN 10204, which will be filed in the installation's technical file.
- All part replacement with other than genuine parts, all modifications of the refrigerating circuit, all replacement of refrigerant by a fluid other than that indicated on the manufacturer's plate, all use of the unit outside the application limits defined in the documentation, shall result in the cancellation of PED CE marking compliance which shall fall under the liability of the individual who carried out these modifications.
- The technical information, relative to the safety requirements of the various applicable directives, is indicated on the manufacturer's plate of the unit and mentioned on the 1st page of this manual.

10 - CIRCULATOR CURVES

PHRT 7
PHRT 9

CIRCULATOR SXM 32 - 55

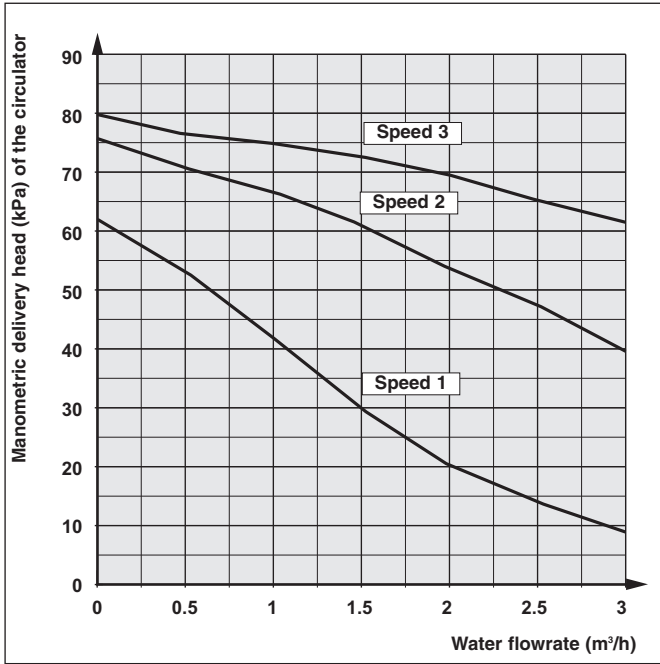

PHRT 12

CIRCULATOR UPS 25 - 125

GB

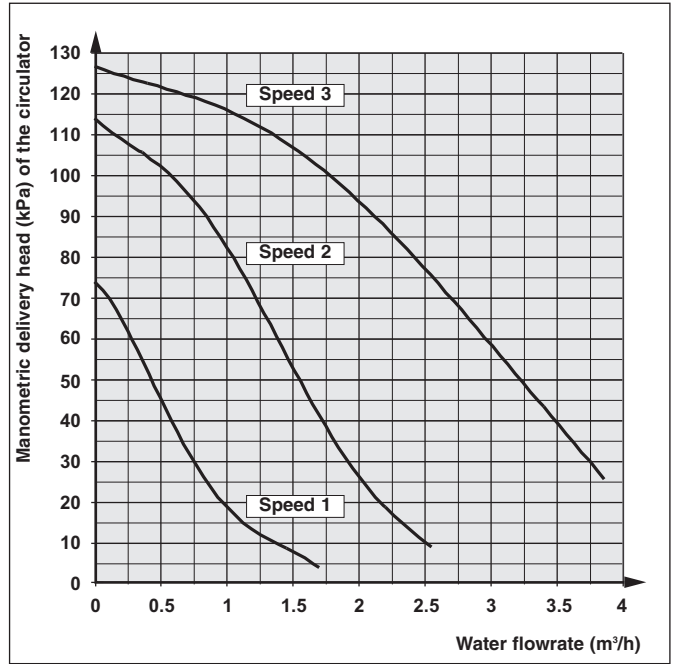

PHRT 16

CIRCULATOR SXM 32 - 80

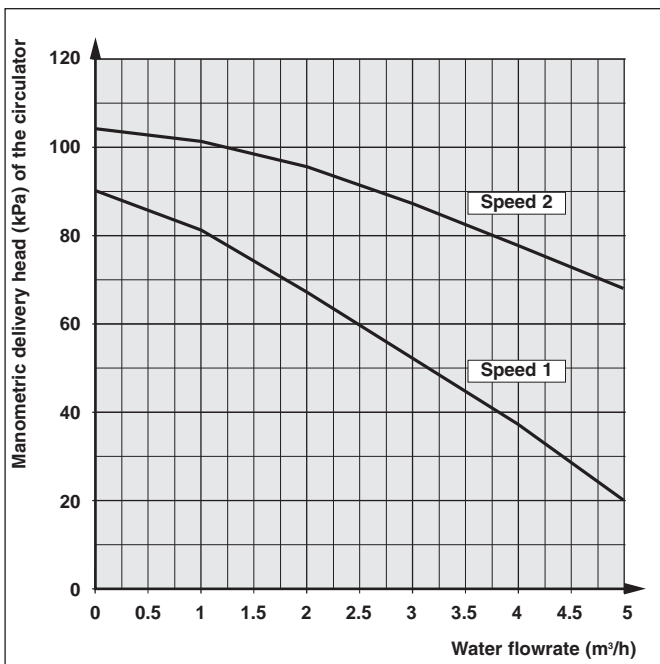

11 - PRESSURE CURVES

11.1 - HEATING MODE

GB

LOW PRESSURE

HIGH PRESSURE

PHRT 7

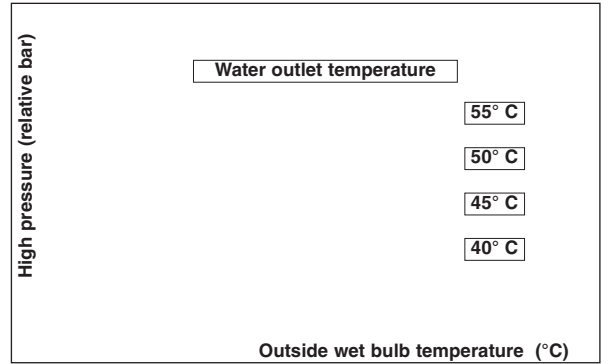
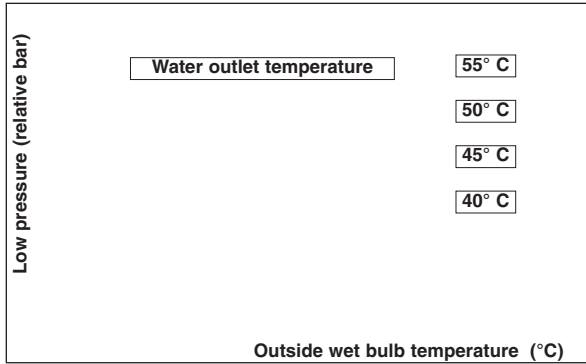

PHRT 9

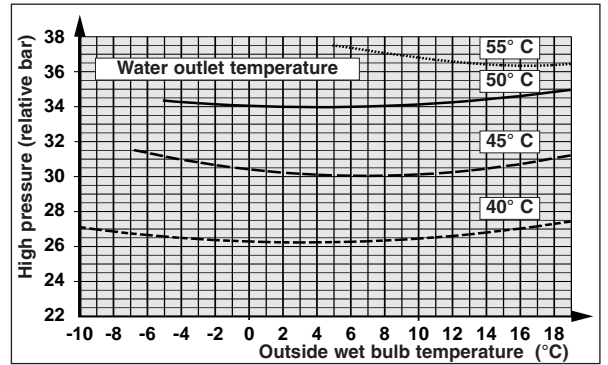
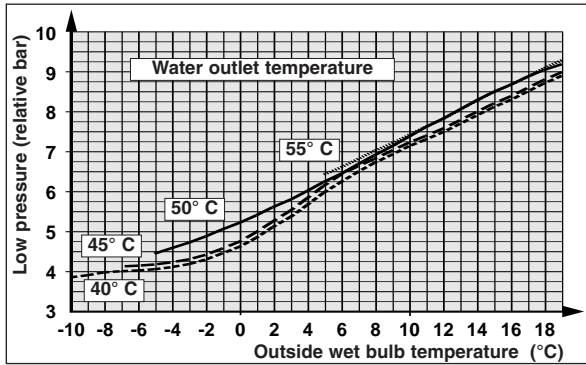

PHRT 12
mono

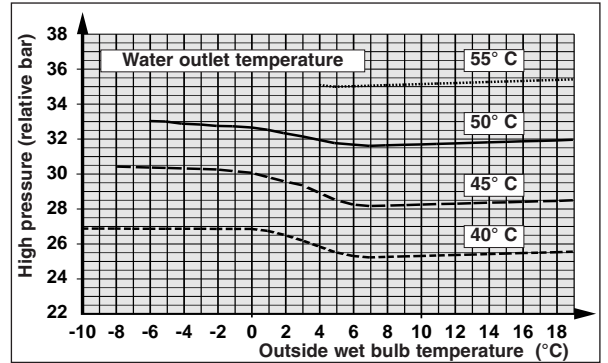
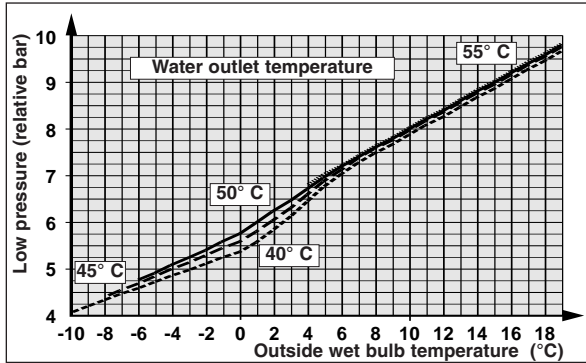

PHRT 12
tri

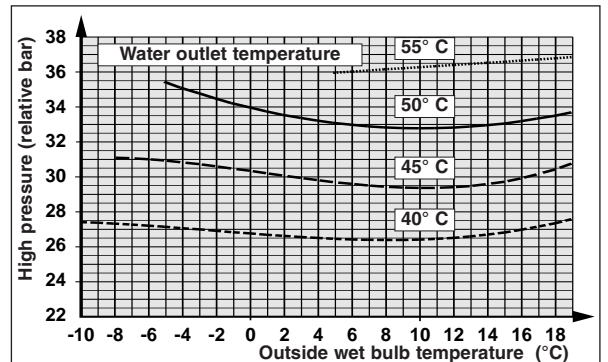
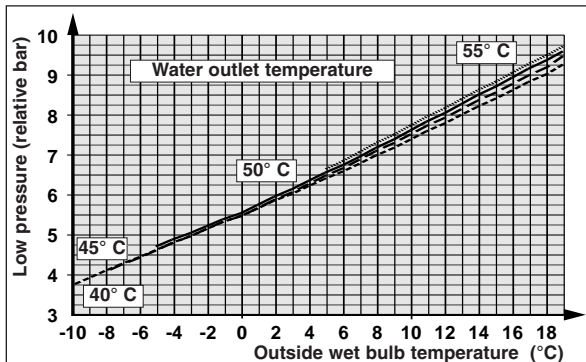

PHRT 16

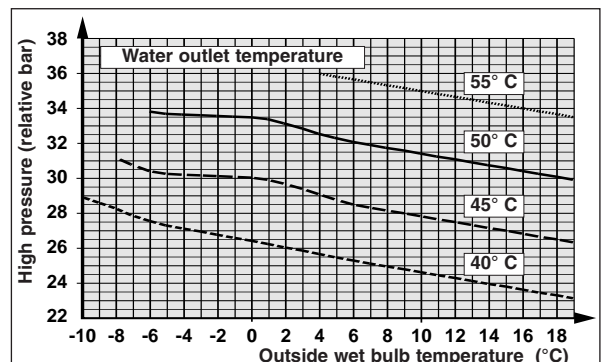
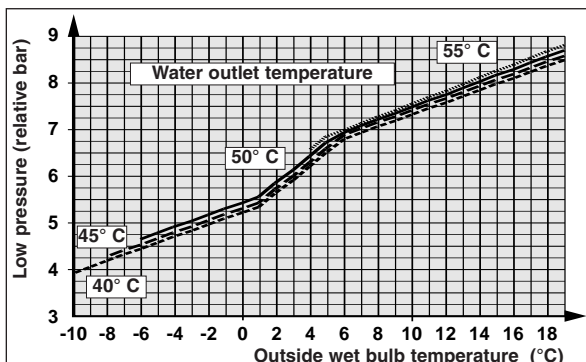

11.2 - COOLING MODE

LOW PRESSURE

HIGH PRESSURE

PHRT 7

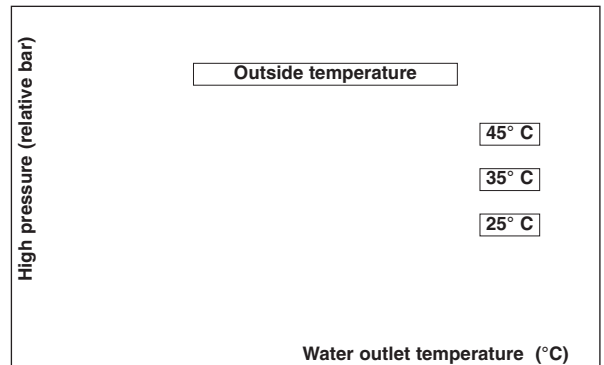
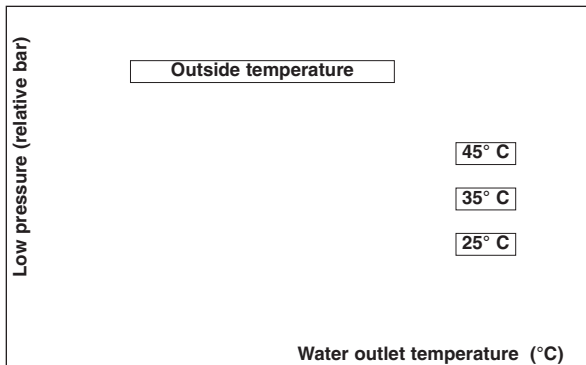

PHRT 9

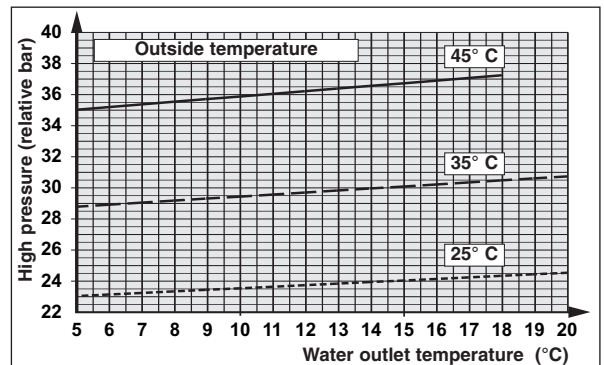
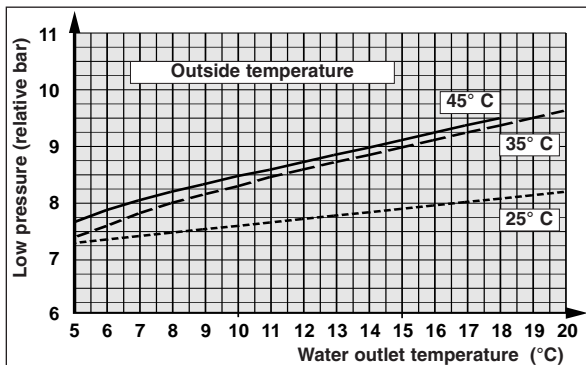

PHRT 12 mono

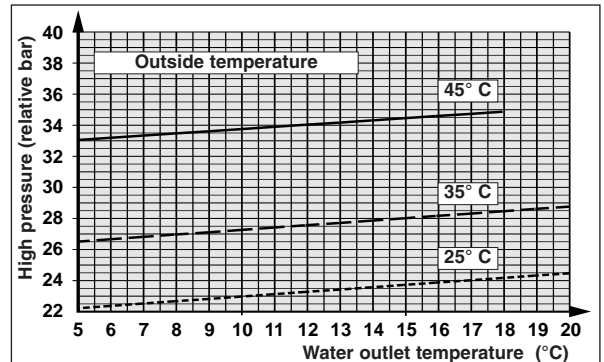
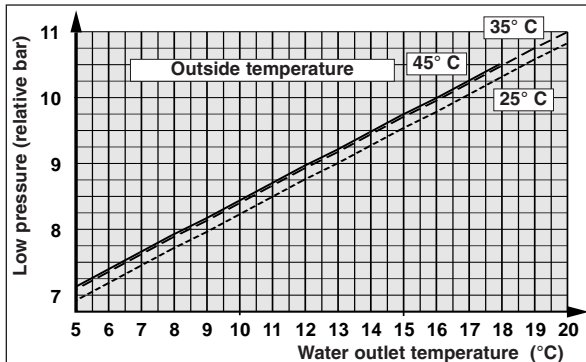

PHRT 12 tri

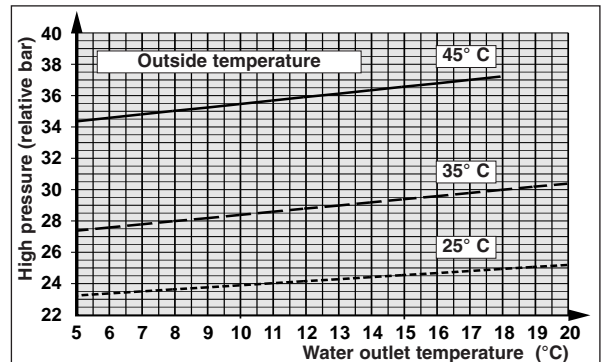
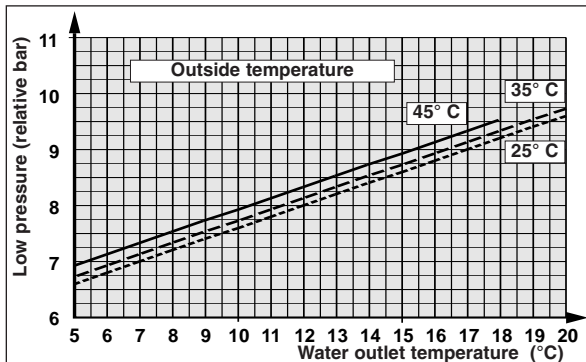

PHRT 16

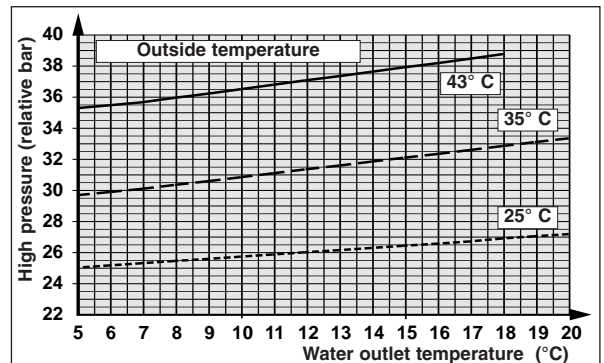
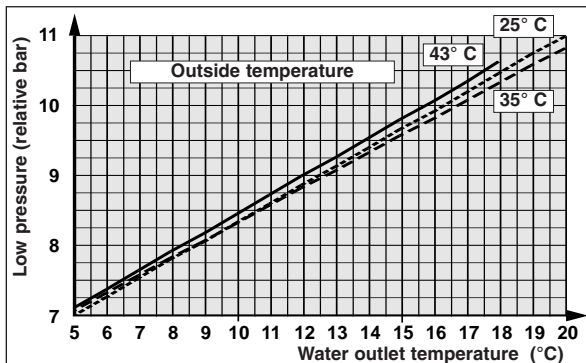

12 - WIRING DIAGRAMS

GB

Symbols of the components

A1 Interface panel	J1 Water differential pressure switch	M3 Circulating pump
A2 Compressor starter	KA1 Phase-sequence controller	R1 Anti-freeze resistor (accessory)
B1 Controller	KA2 Auxiliary relay	SD1 Water inlet probe
C1 M1 capacitor	KA3 Time delay relay	SD2 Water outlet probe
C11 M11 capacitor	KM2 Contactor compressor	SD3 Condensation or defrosting temperature probe
C2 M2 capacitor	KM3 Circulator contactor	SD4 Outside air probe
C3 Filter	M1 Fan	
E1 High pressure switch	M11 Fan	
E2 Low pressure switch	M2 Compressor	
EV1 Electrovalve		

Colours of the wires

B	Blue
G	Grey
M	Brown
L	Purple
P	Pink
N	Black
R	Red
W	White

ELECTRICAL DIAGRAM - PHRT 9 - 230/1/50

10 05 822 - 01

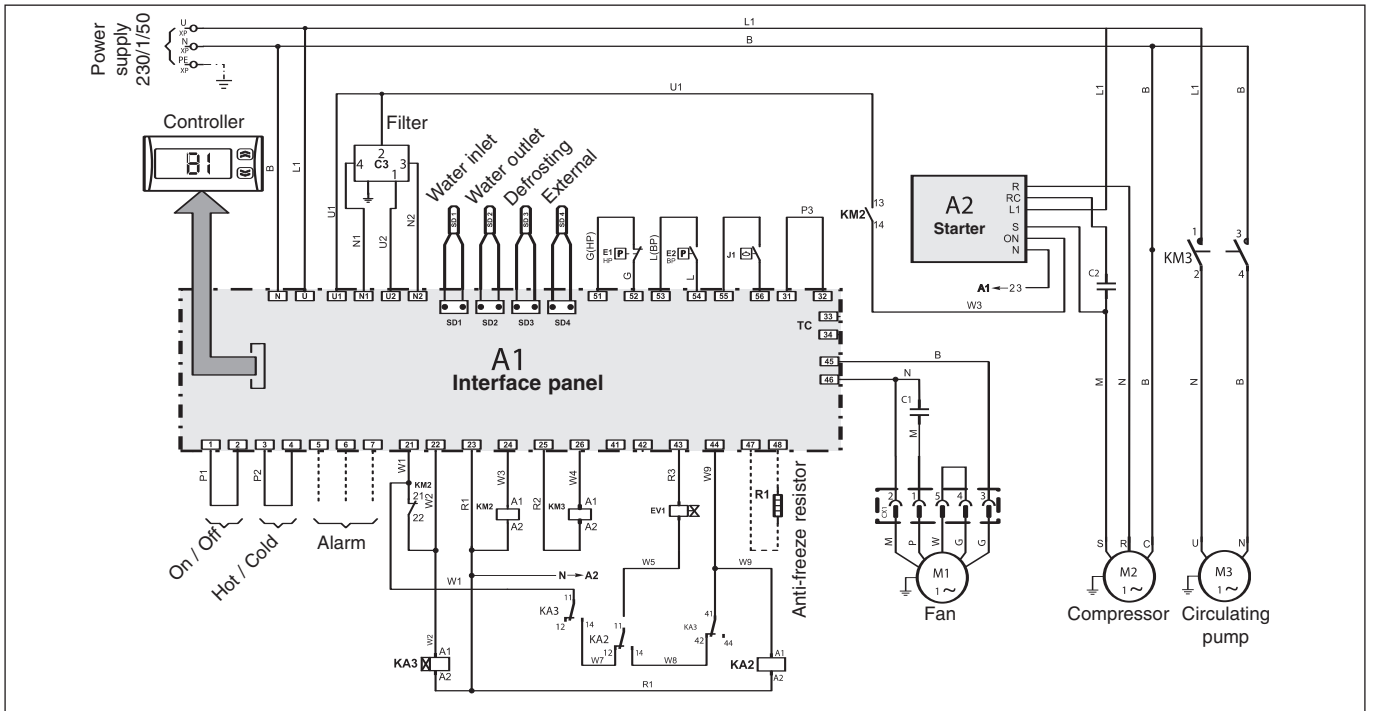

ELECTRICAL DIAGRAM - PHRT 9 - 400/3N/50

00 00 000 - 00

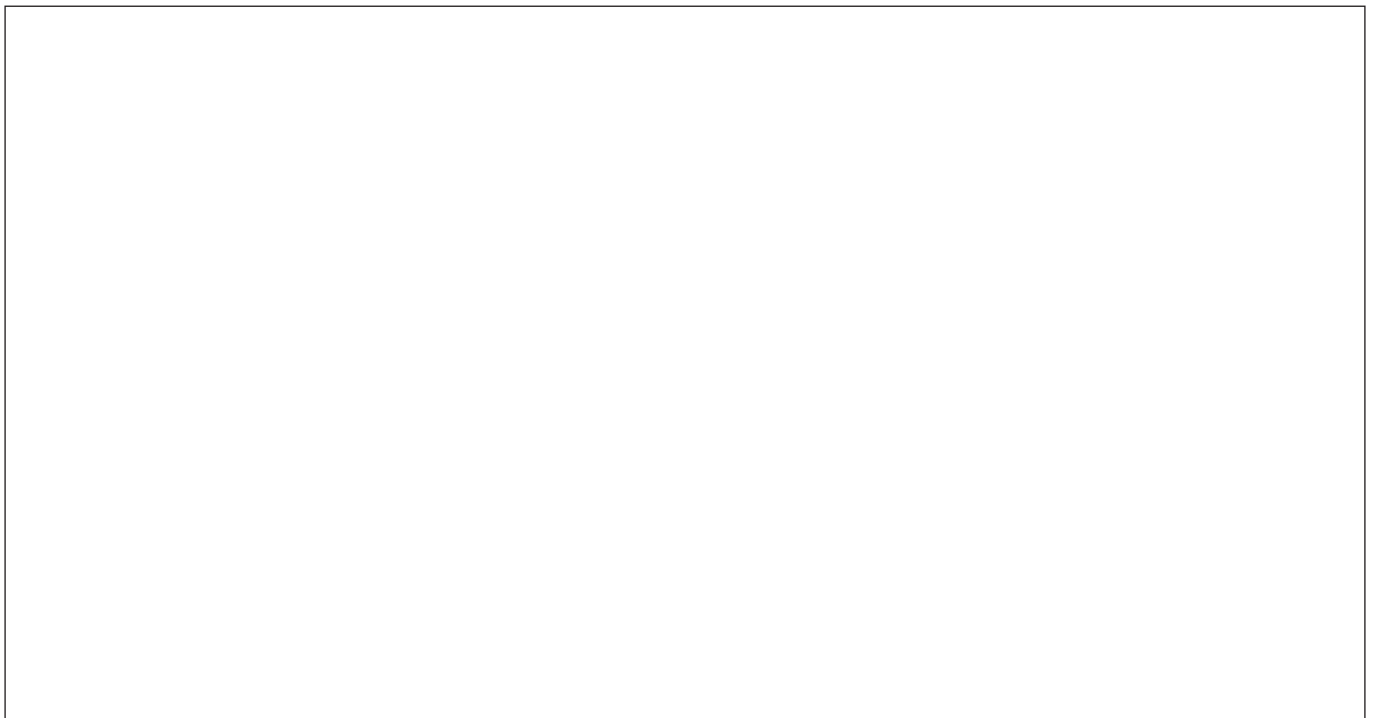

ELECTRICAL DIAGRAM - PHRT 12 - 230/1/50

10 05 823 - 01

GB

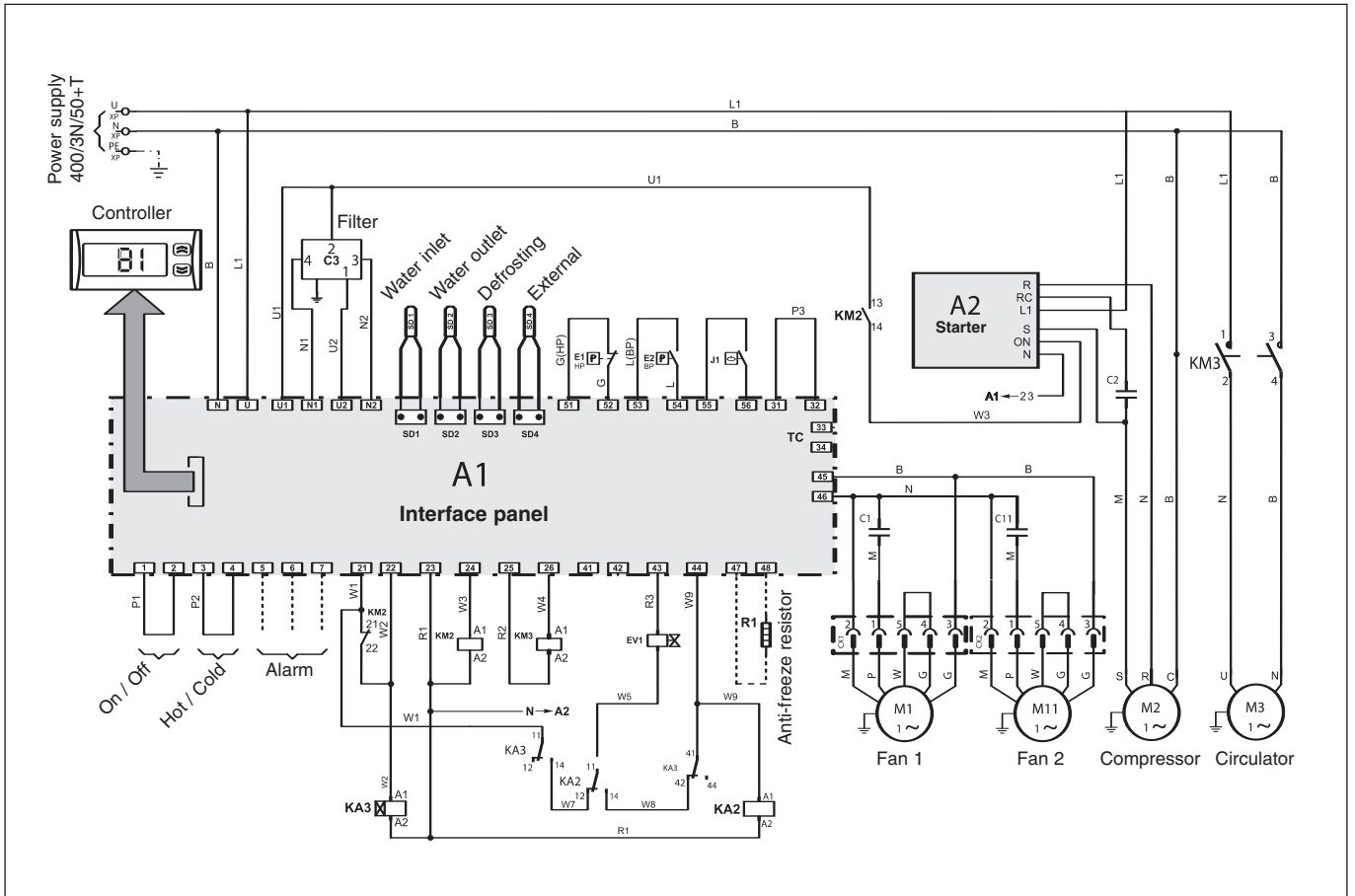

ELECTRICAL DIAGRAM - PHRT 12/16 - 400/3N/50

10 05 816 - 00

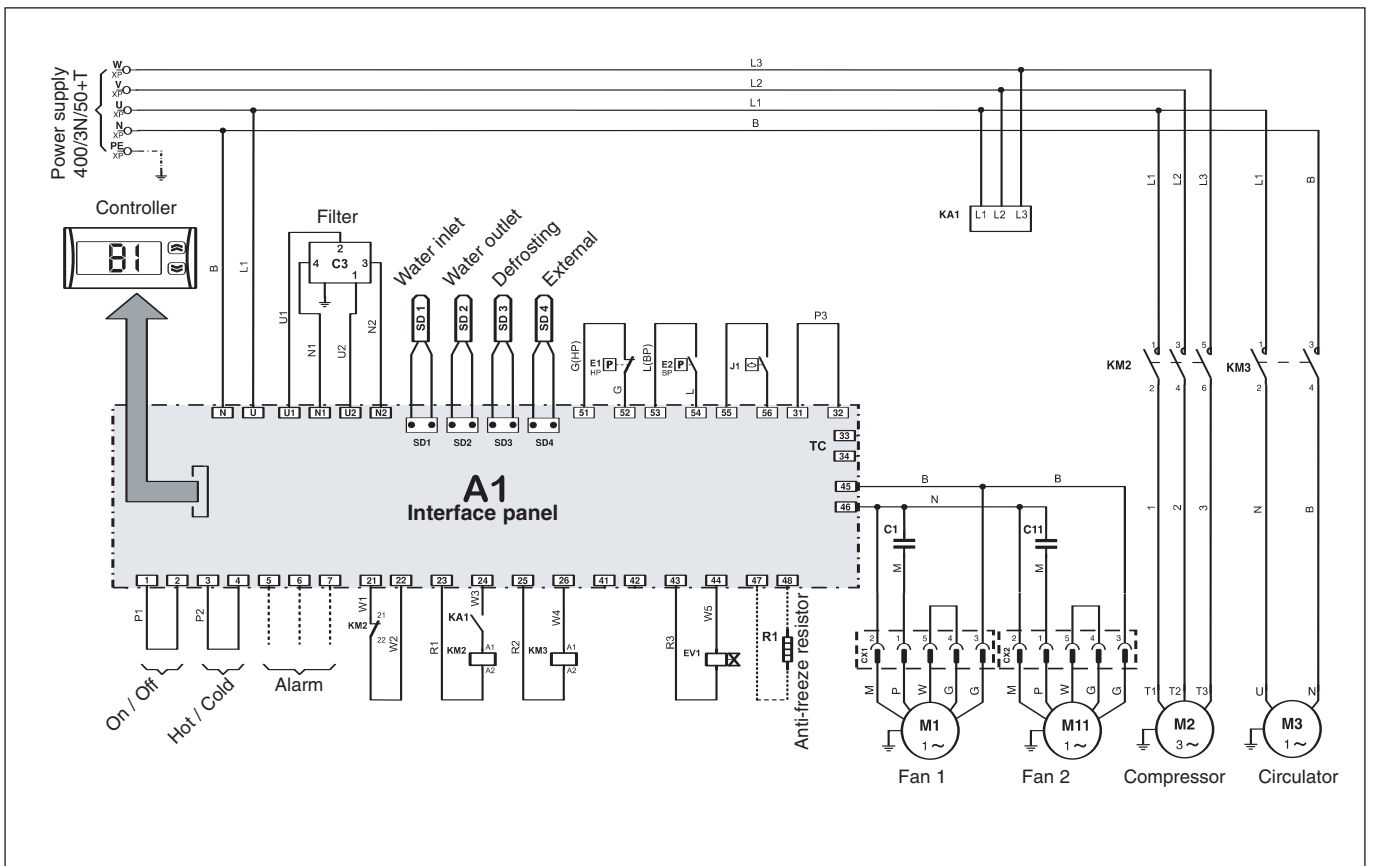

F

GB

I

E

D



Par souci d'amélioration constante, nos produits peuvent être modifiés sans préavis.
Due to our policy of continuous development, our products are liable to modification without notice.
Per garantire un costante miglioramento dei nostri prodotti, ci riserviamo di modificarli senza preavviso.
En el interés de mejoras constantes, nuestros productos pueden modificarse sin aviso previo.
Unsere Produkte werden laufend verbessert und können ohne Vorankündigung abgeändert werden.

Technibel

R.D. 28 Reyrieux BP 131 01601 Trévoux CEDEX France

Tél. 04 74 00 92 92 - Fax 04 74 00 42 00

Tel. 33 4 74 00 92 92 - Fax 33 4 74 00 42 00

R.C.S. Bourg-en-Bresse B 759 200 728