

Pos.	Menge	Bauteilnummer	Abmessungen	Material
S01	1	0005285-S01	IPB 160 L=1210	S235JR (1.0038)
S02	1	0005285-S02	IPB 160 L=358	S235JR (1.0038)
S03	1	0005285-S03	300x160x12	S235JR (1.0038)
S04	1	0005285-S04	300x190x12	S235JR (1.0038)
S05	1	0005285-S05	480x200x230	S235JR (1.0038)
S06	1	0005285-S06	320x200x20	S235JR (1.0038)
S07	1	0005285-S07	265x149x20	S235JR (1.0038)

0005285-S04
(1:5)

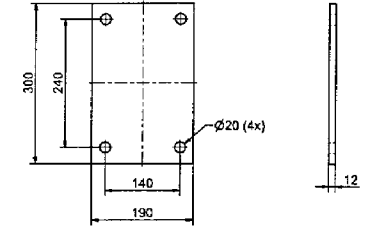

0005285-S05
(1:10)

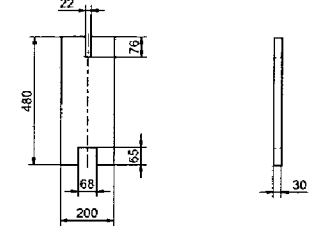

0005285-S06
(1:5)

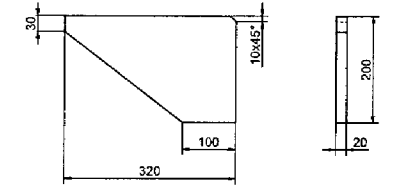

0005285-S07
(1:5)

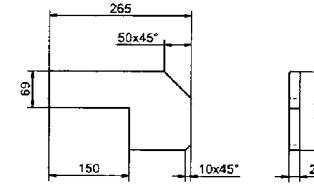

Schweißverfahren: MAG
Zusatzwerkstoff: SG 2
Hilfsstoffe: Argon +18% CO2
Unberauste Kehlnähte: a6
Sandgestraht und spannungsarm gegläht!

Art-Nr.	Bezeichnung	Menge	Einheit	Gewicht
0005285	FERT.4.0005285	1	Stk	107,06 kg

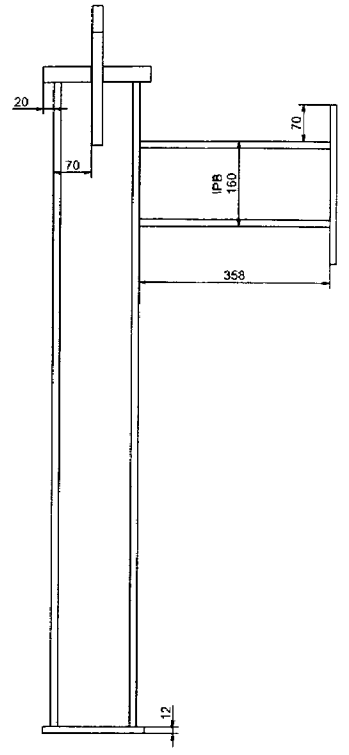
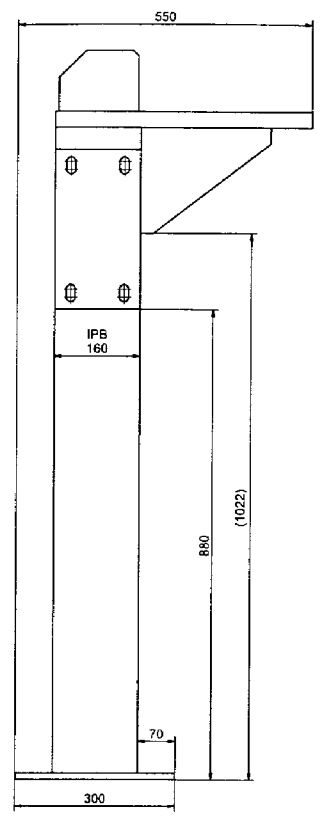
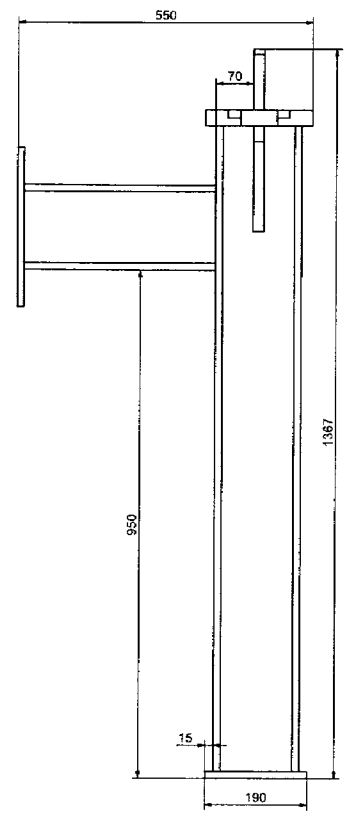

0005285-S03
(1:5)

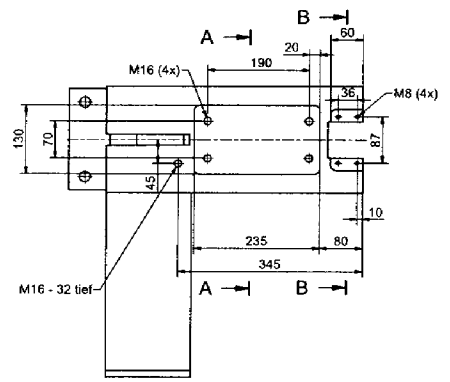
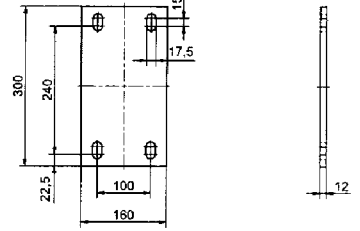

(1:10)

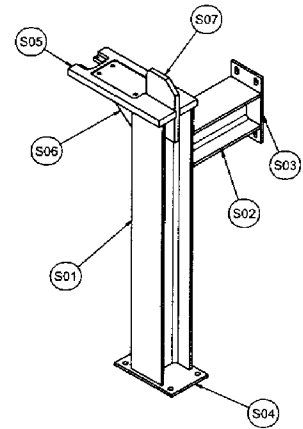

A-A (1:5)

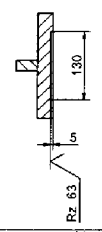

B-B (1:5)

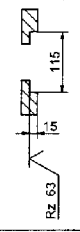

Zeichnung	Name	Stand

FERT.4.0005285
A1

Abbildung Fertigung Fertigungsart Fertigungsdatum Fertiger Zeichner Gezeichnet Geprüft Freigegeben Datum Unterschrift	
Abbildung Fertigungsart Fertigungsdatum Fertiger Zeichner Gezeichnet Geprüft Freigegeben Datum Unterschrift	
Abbildung Fertigungsart Fertigungsdatum Fertiger Zeichner Gezeichnet Geprüft Freigegeben Datum Unterschrift	

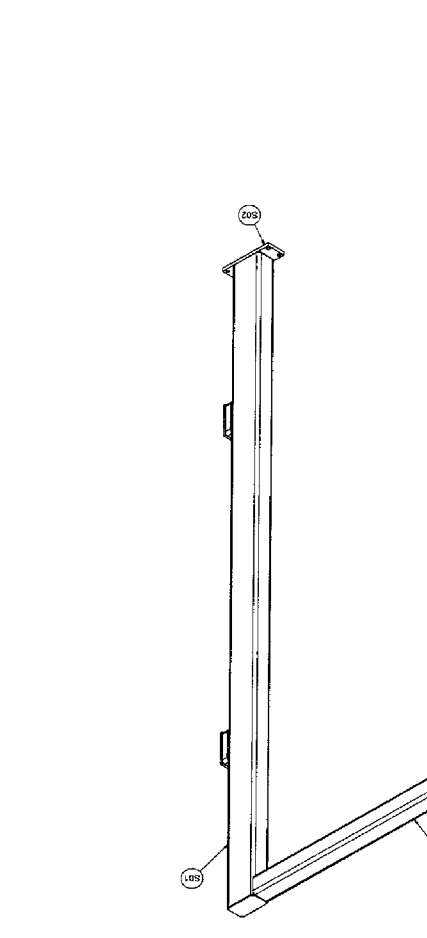
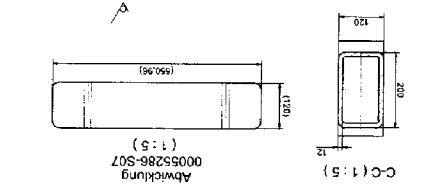

Pos.	Menge	Bezeichnung	Material
S07	1	00055286-S01	200x120x12 E-1185
S08	2	00055286-S02	200x120x12
S09	4	00055286-S03	200x120x12 E-40
S04	4	00055286-S04	200x120x15
S05	1	00055286-S05	200x120x12 E-2560
S06	1	00055286-S06	200x120x12 E-185
S07	1	00055286-S07	55x120x8
S08	2	00055286-S08	194x114x3

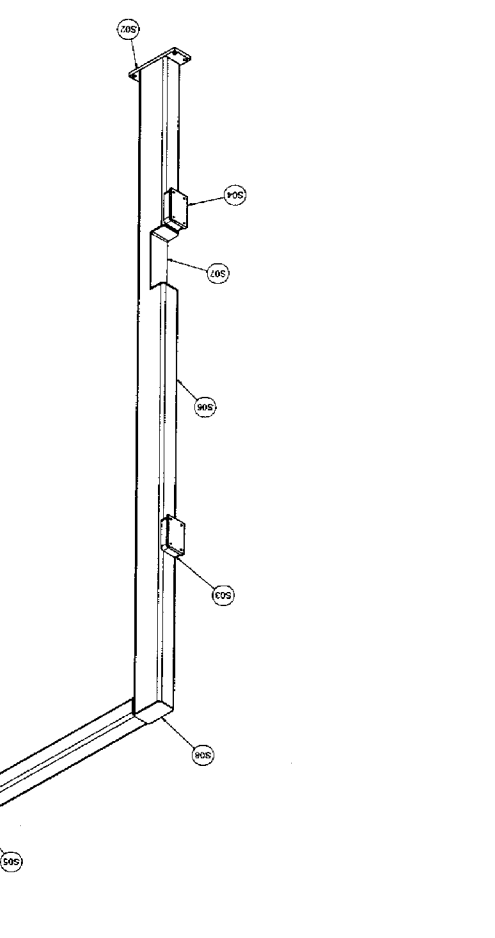
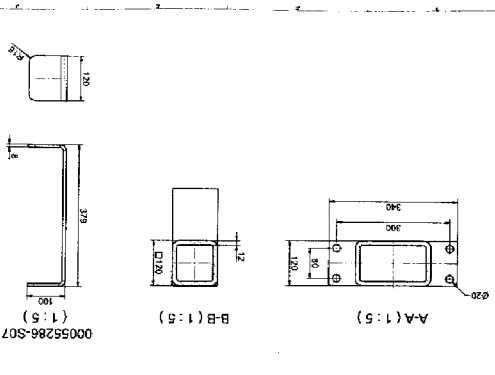

Pos.	Menge	Bezeichnung	Material
S07	1	00055286-S01	200x120x12 E-1185
S08	2	00055286-S02	200x120x12
S09	4	00055286-S03	200x120x12 E-40
S04	4	00055286-S04	200x120x15
S05	1	00055286-S05	200x120x12 E-2560
S06	1	00055286-S06	200x120x12 E-185
S07	1	00055286-S07	55x120x8
S08	2	00055286-S08	194x114x3

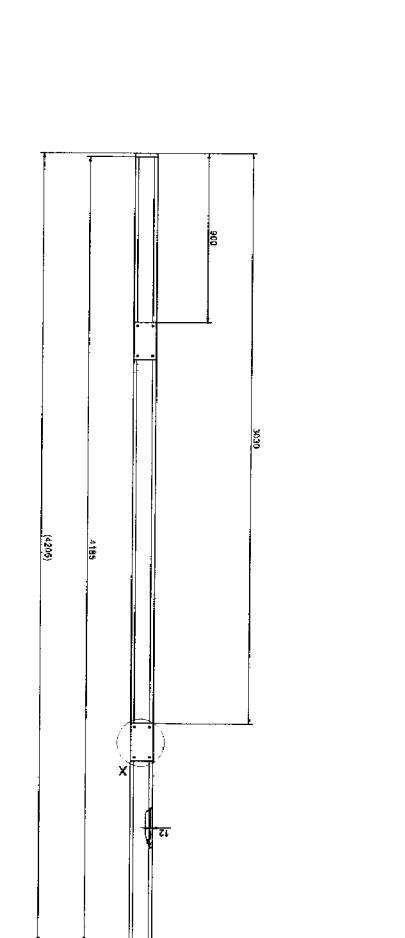
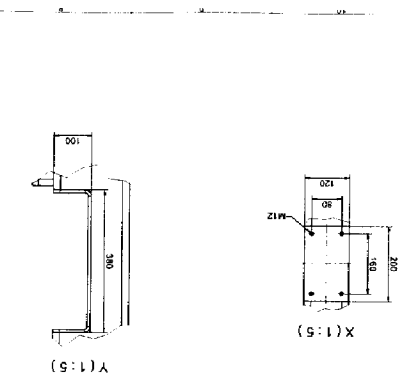

Pos.	Menge	Bezeichnung	Material
S07	1	00055286-S01	200x120x12 E-1185
S08	2	00055286-S02	200x120x12
S09	4	00055286-S03	200x120x12 E-40
S04	4	00055286-S04	200x120x15
S05	1	00055286-S05	200x120x12 E-2560
S06	1	00055286-S06	200x120x12 E-185
S07	1	00055286-S07	55x120x8
S08	2	00055286-S08	194x114x3

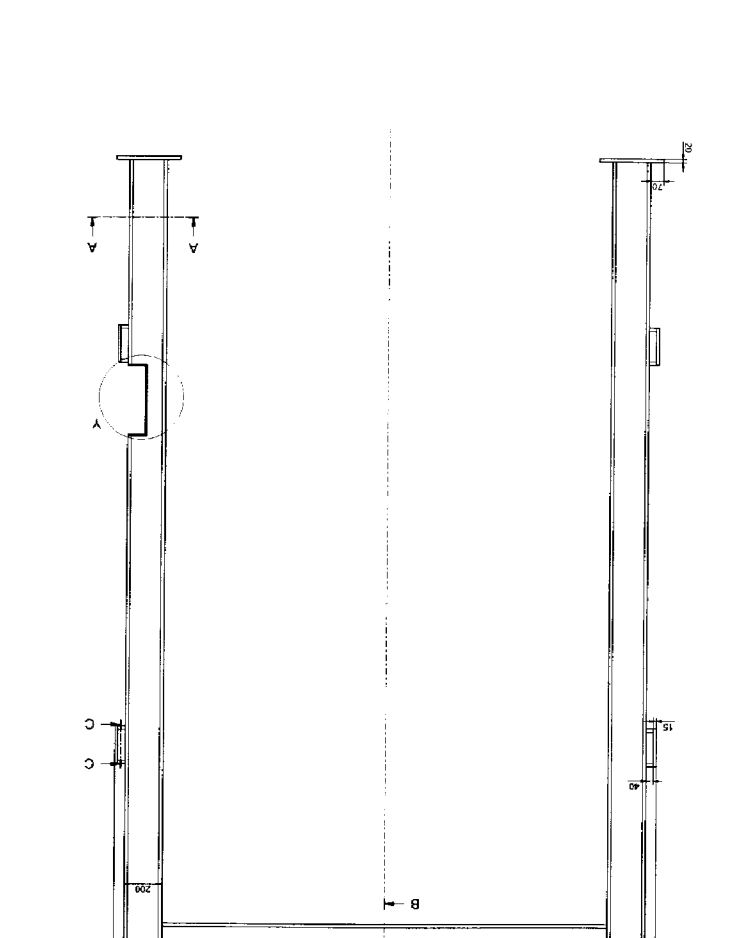
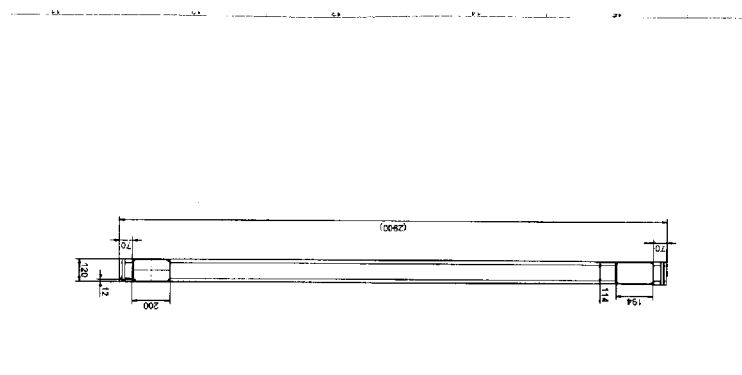

Pos.	Menge	Bezeichnung	Material
S07	1	00055286-S01	200x120x12 E-1185
S08	2	00055286-S02	200x120x12
S09	4	00055286-S03	200x120x12 E-40
S04	4	00055286-S04	200x120x15
S05	1	00055286-S05	200x120x12 E-2560
S06	1	00055286-S06	200x120x12 E-185
S07	1	00055286-S07	55x120x8
S08	2	00055286-S08	194x114x3