

Diese Zeichnung ist unser alleiniges Eigentum und darf ohne ausdrückliche Genehmigung weder vervielfältigt noch an Dritte weitergegeben werden.

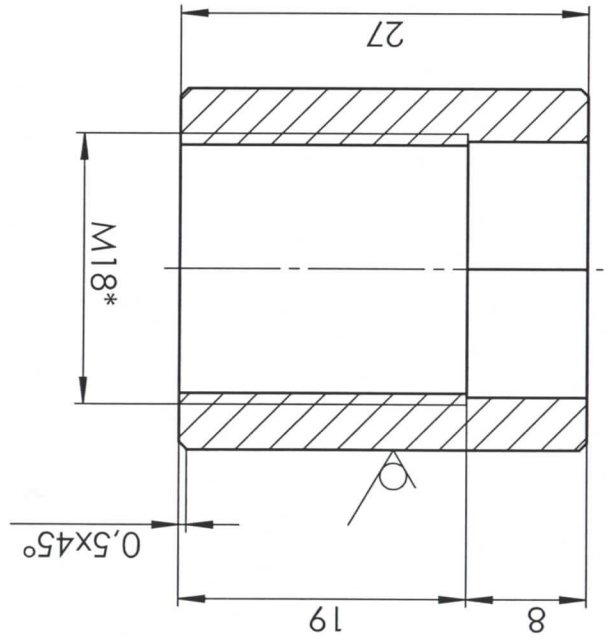

* M18 nach Antriebsmaschine

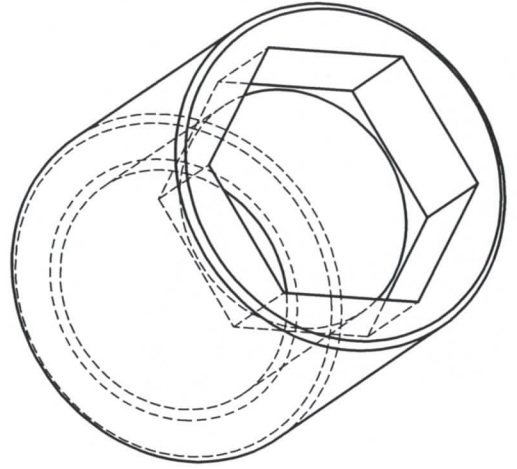
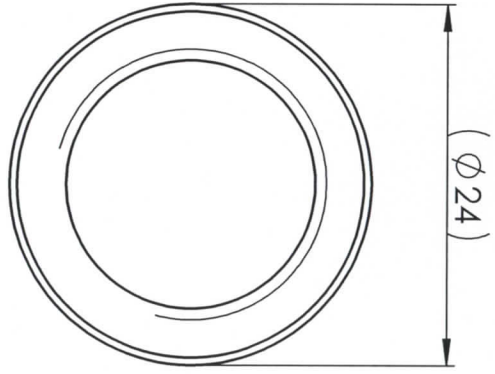

DIN ISO 13715 $\sqrt{0,2}$

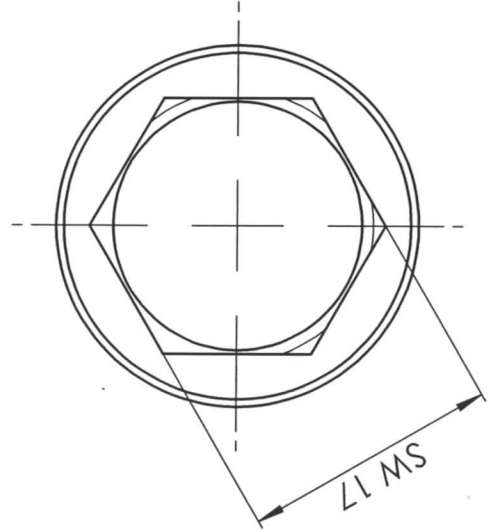

Zust.		Änderung		Datum		Name		Ursprung: 454410-2.pt	
1		überarbeitet		20.7.11		ochman		454410	
2		Halbzeug geändert		29.10.21		kschne		454410-2	
								Ersatz für: 454410.pt	
								Ersatz durch:	
								454410-2	
								Zeichnungsnummer	
								454410-2	
								Version	
								2	
								Format	
								A4	
								Maxiplast	
								Kupplungsstück mit Sechskant	
								Benennung	
								42CrMo4	
								Werkstoff/ Halbzeug	
								Ø24, L=30	
								Masstab 2:1 (2:1)	
								Gewicht 0,05 kg	
								1 Stück/ Maschine	
								Mache ohne Toleranz	
								DIN ISO 2768 mk	
								DIN ISO 13715	
								Datum	
								15.7.09	
								Bearb.	
								MDommer	
								Gepr.	
								Name	
								Datum	
								15.7.09	
								Bearb.	
								MDommer	
								Gepr.	
								Name	
								Datum	
								15.7.09	
								Bearb.	
								MDommer	
								Gepr.	
								Name	
								Datum	
								15.7.09	
								Bearb.	
								MDommer	
								Gepr.	
								Name	
								Datum	
								15.7.09	
								Bearb.	
								MDommer	
								Gepr.	
								Name	
								Datum	
								15.7.09	
								Bearb.	
								MDommer	
								Gepr.	
								Name	
								Datum	
								15.7.09	
								Bearb.	
								MDommer	
								Gepr.	
								Name	
								Datum	
								15.7.09	
								Bearb.	
								MDommer	
								Gepr.	
								Name	
								Datum	
								15.7.09	
								Bearb.	
								MDommer	
								Gepr.	
								Name	
								Datum	
								15.7.09	
								Bearb.	
								MDommer	
								Gepr.	
								Name	
								Datum	
								15.7.09	
								Bearb.	
								MDommer	
								Gepr.	
								Name	
								Datum	
								15.7.09	
								Bearb.	
								MDommer	
								Gepr.	
								Name	
								Datum	
								15.7.09	
								Bearb.	
								MDommer	
								Gepr.	
								Name	
								Datum	
								15.7.09	
								Bearb.	
								MDommer	
								Gepr.	
								Name	
								Datum	
								15.7.09	
								Bearb.	
								MDommer	
								Gepr.	
								Name	
								Datum	
								15.7.09	
								Bearb.	
								MDommer	
								Gepr.	
								Name	
								Datum	
								15.7.09	
								Bearb.	
								MDommer	
								Gepr.	
								Name	
								Datum	
								15.7.09	
								Bearb.	
								MDommer	
								Gepr.	
								Name	
								Datum	
								15.7.09	
								Bearb.	
								MDommer	
								Gepr.	
								Name	
								Datum	
								15.7.09	
								Bearb.	
								MDommer	
								Gepr.	
								Name	
								Datum	
								15.7.09	
								Bearb.	
								MDommer	
								Gepr.	
								Name	
								Datum	
								15.7.09	
								Bearb.	
								MDommer	
								Gepr.	
								Name	
								Datum	
								15.7.09	
								Bearb.	
								MDommer	
								Gepr.	
								Name	
								Datum	
								15.7.09	
								Bearb.	
								MDommer	
								Gepr.	
								Name	
								Datum	
								15.7.09	
								Bearb.	
								MDommer	
								Gepr.	
								Name	
								Datum	
								15.7.09	
								Bearb.	
								MDommer	
								Gepr.	
								Name	
								Datum	
								15.7.09	
								Bearb.	
								MDommer	
								Gepr.	
								Name	
								Datum	
								15.7.09	
								Bearb.	
								MDommer	
								Gepr.	
								Name	
								Datum	
								15.7.09	
								Bearb.	
								MDommer	
								Gepr.	
								Name	
								Datum	
								15.7.09	
								Bearb.	
								MDommer	
								Gepr.	
								Name	
								Datum	
								15.7.09	
								Bearb.	
								MDommer	
								Gepr.	
								Name	
								Datum	
								15.7.09	
								Bearb.	
								MDommer	
								Gepr.	
								Name	
								Datum	
								15.7.09	
								Bearb.	
								MDommer	
								Gepr.	
								Name	
								Datum	
								15.7.09	
								Bearb.	
								MDommer	
								Gepr.	
								Name	
								Datum	

