

A-A (1:2)

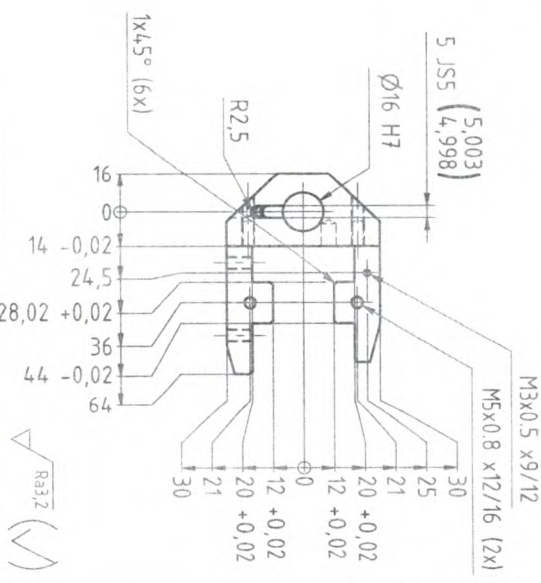
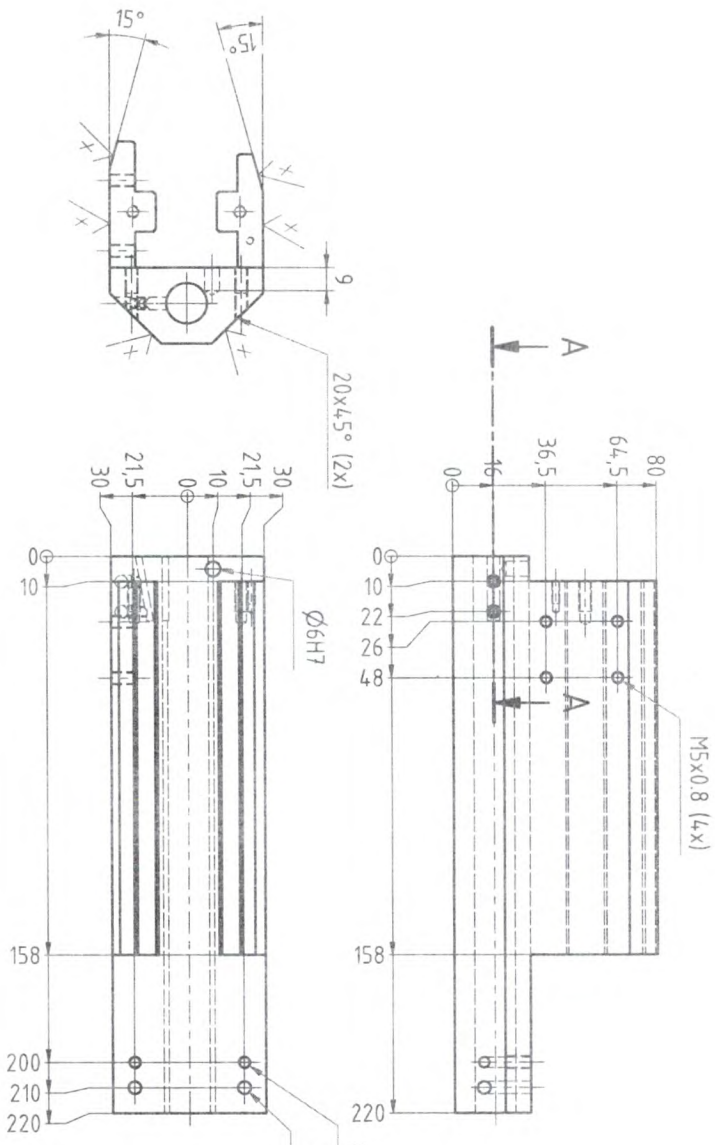
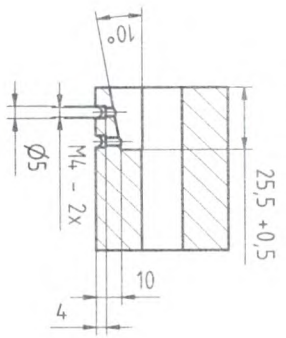

2 Ls
1A3A2

Alle Kanten 0.5x4.5° gebrochen
all edges removed 0.5x4.5°

LAGERTOLERANZEN ISO 1101 position tolerances ISO 1101	01	0.01	OBERFLÄCHE BOHRUNGEN SURFACE HOLES	Passungen fits
SCHRAUBTOLERANZEN ISO 1101 SCREW TOLERANCES	01	0.01	SCHRAUBENBOHRER SCREW HOLES	Passungen fits

Schutzvermerk / Protection notice
The reproduction, distribution and utilization of this document as well as the communication of its contents to others without explicit authorization is prohibited. Offenders will be held liable for the payment of damages. All rights reserved in the event of the grant of a patent, utility model or design.

General tolerances according to ISO 2768-mS	h6	H7	h6	H7	h6	H7	h6	H7	h6	H7
Form tolerances according to ISO 13715	0.1	0.1	0.1	0.1	0.1	0.1	0.1	0.1	0.1	0.1
Internal chamfers according to ISO 413	0.5	0.5	0.5	0.5	0.5	0.5	0.5	0.5	0.5	0.5
External chamfers according to ISO 413	0.5	0.5	0.5	0.5	0.5	0.5	0.5	0.5	0.5	0.5
Surface texture according to ISO 4191	0.8	0.8	0.8	0.8	0.8	0.8	0.8	0.8	0.8	0.8
Material	Material: 1.2345									
Heat treatment	Heat treatment: none									
Surface treatment	Surface treatment: none									
Welding	Welding: none									
Other	Other: none									
Project/Revision	Project/Revision: 1									
Design number	Design number: 12345									
Drawing title	Drawing title: 12345									
Author	Author: 12345									
Checker	Checker: 12345									
Approver	Approver: 12345									
Date	Date: 12.12.2020									
Version	Version: 1									

