

ŘEZ A-A  
MĚRITKO 1 : 10

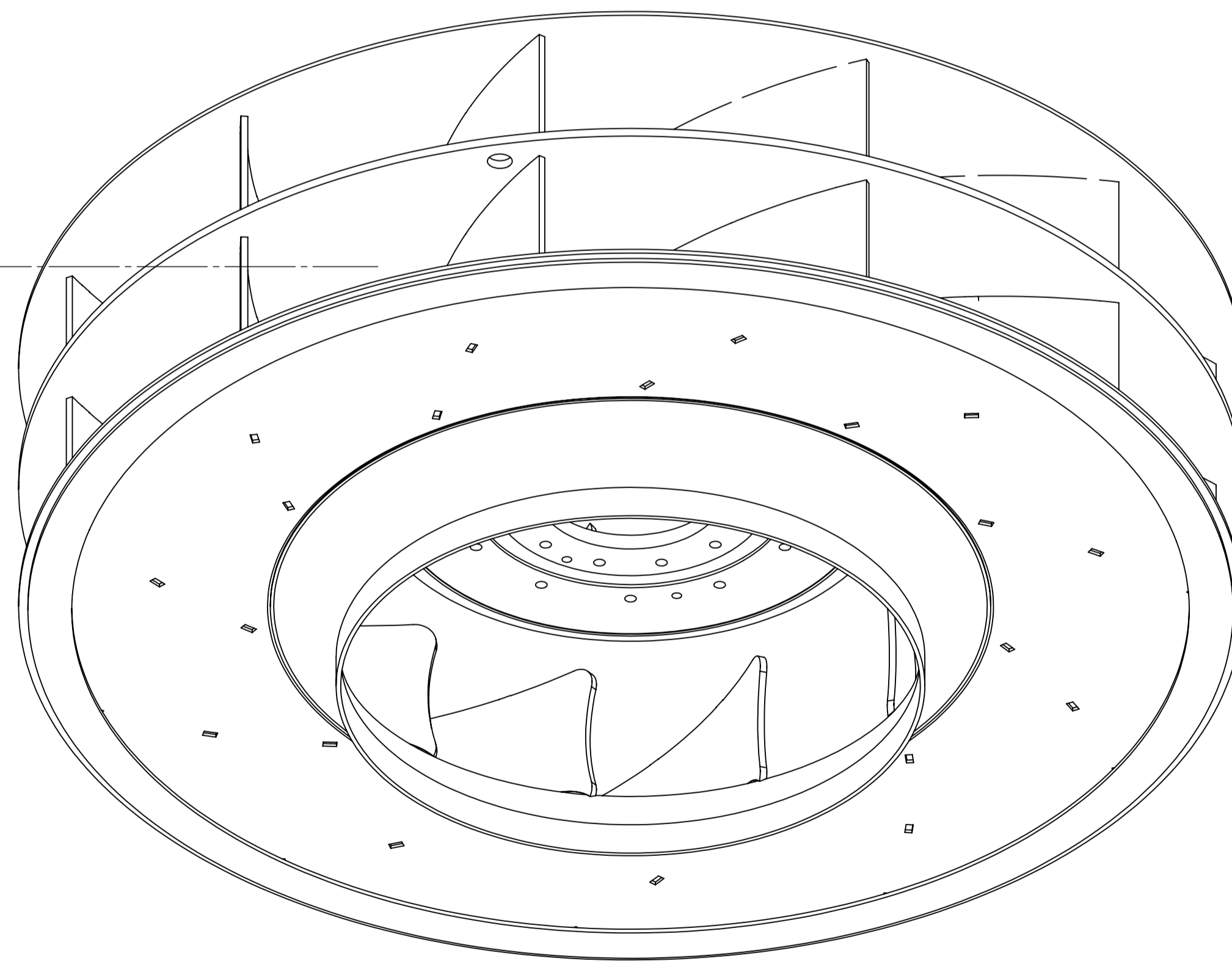
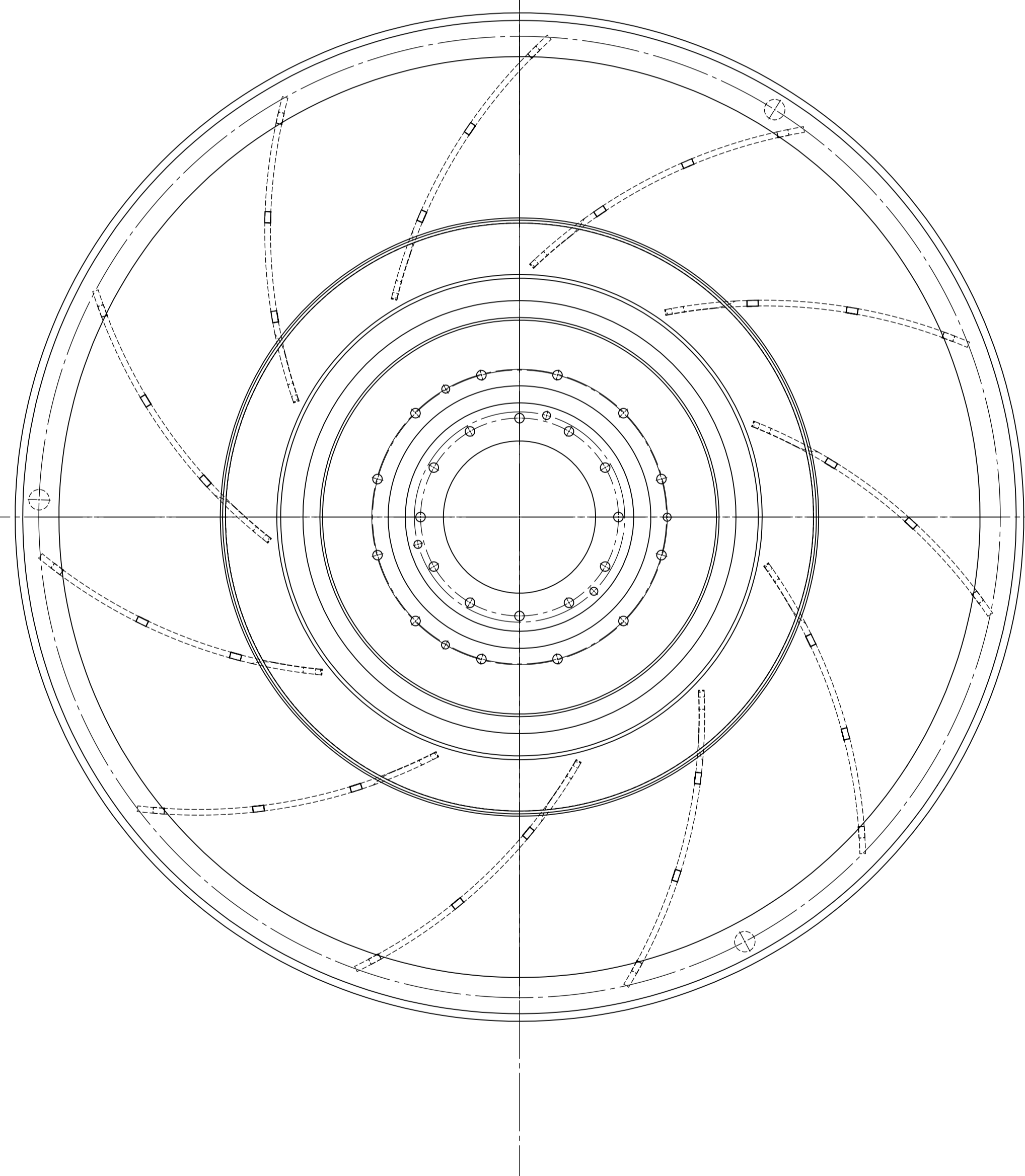

| Poř. číslo | ks | Číslo výkresu   | Název        | Rozměr  | Norma/Typ | Materiál        | Mat. Konečný | Dodavatel     | Objed. číslo | Poznámka | Hmotnost |
|------------|----|-----------------|--------------|---------|-----------|-----------------|--------------|---------------|--------------|----------|----------|
| 1          | 1  | 201924-60       | WELDED       |         | --        | UNDER THE PIECE |              | Amass Chrudim | 201924-60    | Svarek   | 379.27   |
| 2          | 1  | 201924-65       | LOWER FUNNEL |         | --        | UNDER THE PIECE |              | Amass Chrudim | 201924-65    | Svarek   | 379.27   |
| 3          | 1  | 201924-100      | SHEET METAL  | TEMPLAT | --        | 1.0553 (S355J0) |              | Amass Chrudim | 201924-100   |          | 945.83   |
| 4          | 2  | 201924-103      | RING         | TEMPLAT | --        | 1.0553 (S355J0) |              | Amass Chrudim | 201924-103   |          | 58.55    |
| 5          | 11 | 201924-102      | BLADE        | TEMPLAT | --        | 1.0553 (S355J0) |              | Amass Chrudim | 201924-102   |          | 28.34    |
| 6          | 11 | MIRRORING BLADE |              |         |           |                 |              |               |              |          |          |

|  |           |                                      |                 |                                 |           |  |      |
|--|-----------|--------------------------------------|-----------------|---------------------------------|-----------|--|------|
| PIN AND PRECIOUS HOLES ±0.02 Ra 1.6  |           | SURFACE FINISH                       |                 | WELDED a=[mm]                   |           | Dokument je duševním vlastnictvím společnosti Amass Chrudim s. r. o. |      |
| THREAD AND FREE HOLE ±0.2 Ra 6.3   |           |                                      |                 |                                 |           |  |      |
| 50   | 1         | --                                   | UNDER THE PIECE | Amass Chrudim                   | 201924-50 | WELDED   |      |
| POS. PIECE   | DIMENSION | STANDART/TYP                         | MATERIAL        | MATERIAL FINAL                  | CONTRATOR | ORDER NUMBER   | NOTE |
| M 1:20   |           | RELATED ASSEMBLY: CONTRACT:          |                 | NAME                            |           | DRAWING NUMBER   |      |
|  |           |                                      |                 | FAN                             |           | 201924-50  |      |
| Společnost Amass Chrudim s. r. o., Přábov 23, 53821 Slatiňany www.amass.cz |           | Vytvořeno 30. července 2019 12:35:49 |                 | Změněno 14. srpna 2019 10:43:49 |           | Hmotnost 2445.03 kg  |      |