

SECTION A-A

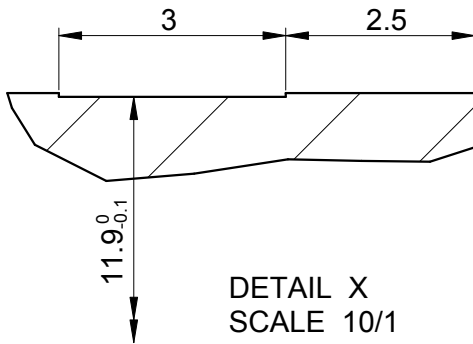

DETAIL X  
SCALE 10/1

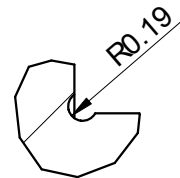

DETAIL Z  
SCALE 10/1

A	chd material				09/12/14	baln
Rev.	Description				Date	Drawn by
Ra <sup>1.6</sup>	Tol. Lin. ±0.1		Tol. Angle ±0.1		Mass (kg) 0.010	
	Material	KL_(1.2550)_60WCrV7	Drawn	LILT		
	Raw Mat.	-	Des.	LILT		
	Hardness	57-58 HRC	Date	04/03/05		
	Mod./Org. nr.	-	Scale	2/1		
Machine	Type	<b>HARDENING PLATE</b> <b>HARDINGSPLAATJE</b> <b>PLAQUE DURCISSEMENT</b> <b>HARD PLATTE</b>			Format	A4
MODUL S	0				Drawing n°/Sheet	Rev.
					S869530000MS - 1 /1	A