

✓ Rz25

		Allgemeintoleranzen nach DIN ISO 2768 - m		Oberfläche nach DIN ISO 1302		Maßstab 1:2,5	Gewicht 5,873 kg	Menge
		Werkstückkanten DIN 6794				S355		
			Datum	Name		Platte		
			Bearb. 17.11.2020	AK				
			Gepr.					
			Norm					
			Gez. 23.11.2020	AH				
				G200033		319-20-05-33-01		Format A4
Nr.:	Änderung	Datum	Name	EDV Nr.				Bl 1

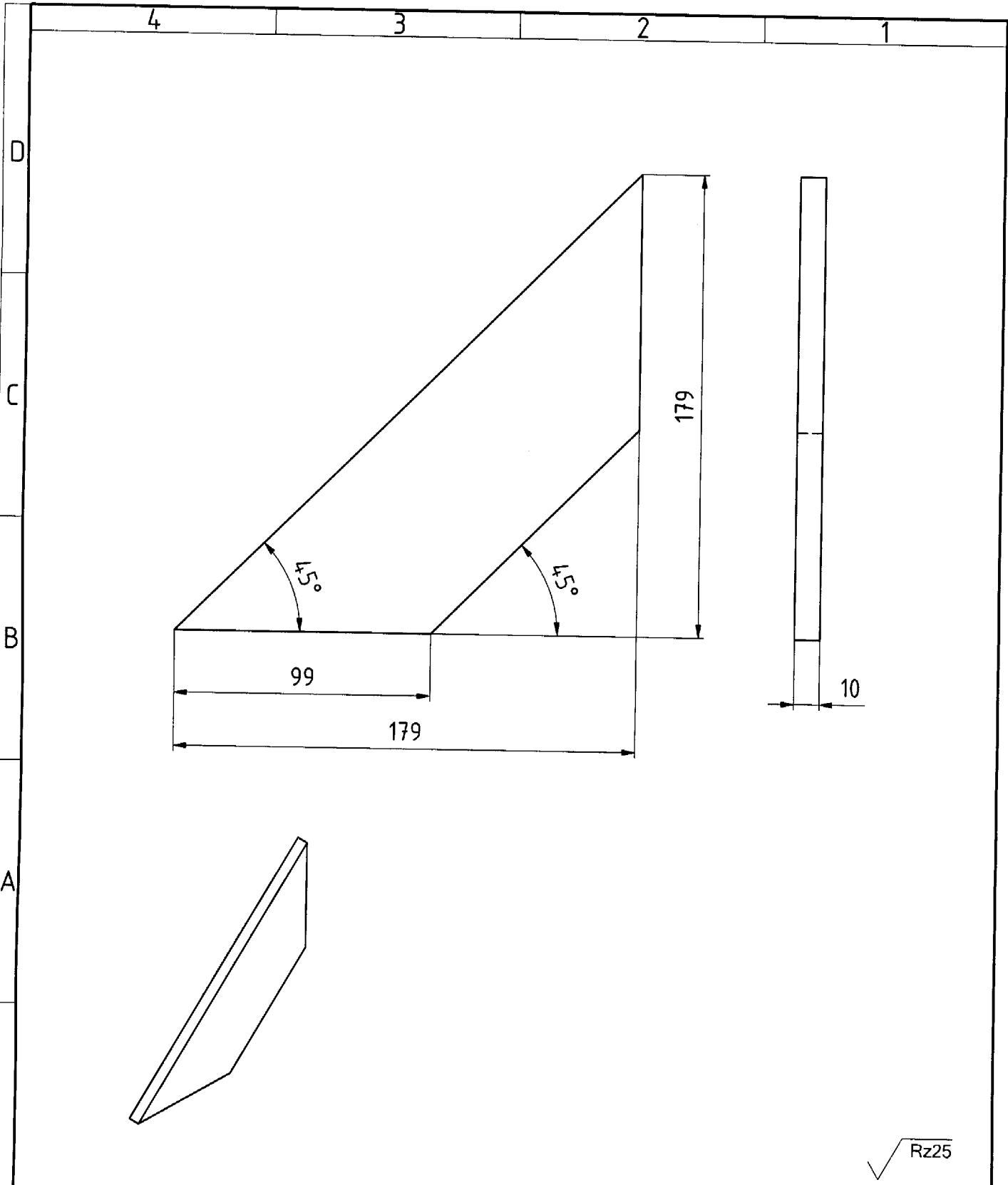

√ Rz25

				Allgemeintoleranzen nach DIN ISO 2768 - m		Oberfläche nach DIN ISO 1302		Maßstab 1:2		Gewicht 1,005 kg Menge	
				Werkstückkanten DIN 6784				S355			
				Datum		Name		Rippe			
				Bearb. 17.11.2020		AK					
				Gepr.							
				Norm							
				Gez. 23.11.2020		AH					
				G200033				319-20-05-33-03			
								Format A4			
								Bl 1			
Nr.:	Änderung			Datum	Name	EDV Nr.					