

Procédé Soudure / Welding process 111
 a = 0,7 x ep. mini / th. mini
 Sauf indications / Except Indications

Unless Otherwise Indicated

Casser les angles vifs / Remove sharp edges

Item	Qty	Description	MATERIAL
1	1	Plat	Steel S235 JR or AISI 1018
2	1	Axe	Steel S235 JR or AISI 1018
3	2	Cale	Steel S235 JR or AISI 1018
4	2	Support bille	Steel S235 JR or AISI 1018
5	2	Plat de liaison	Steel S235 JR or AISI 1018
6	1	Support ressort	Steel S235 JR or AISI 1018

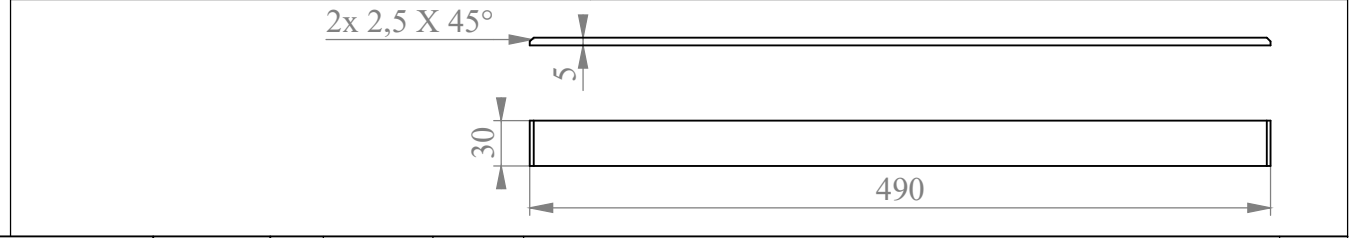
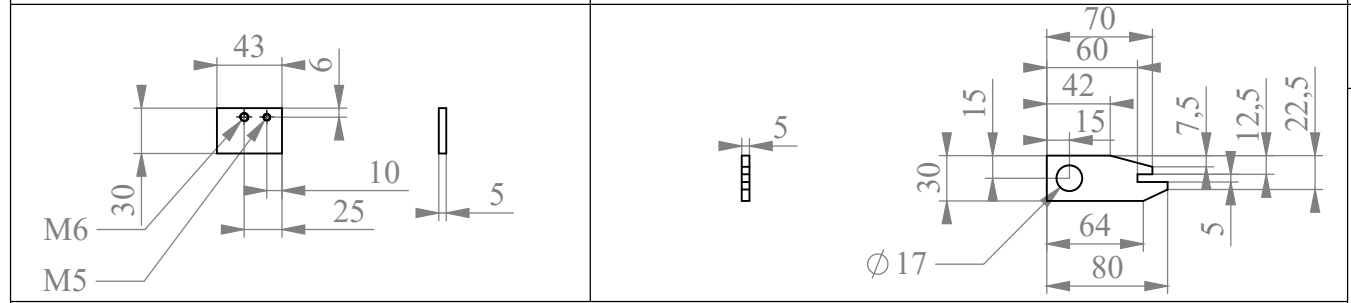
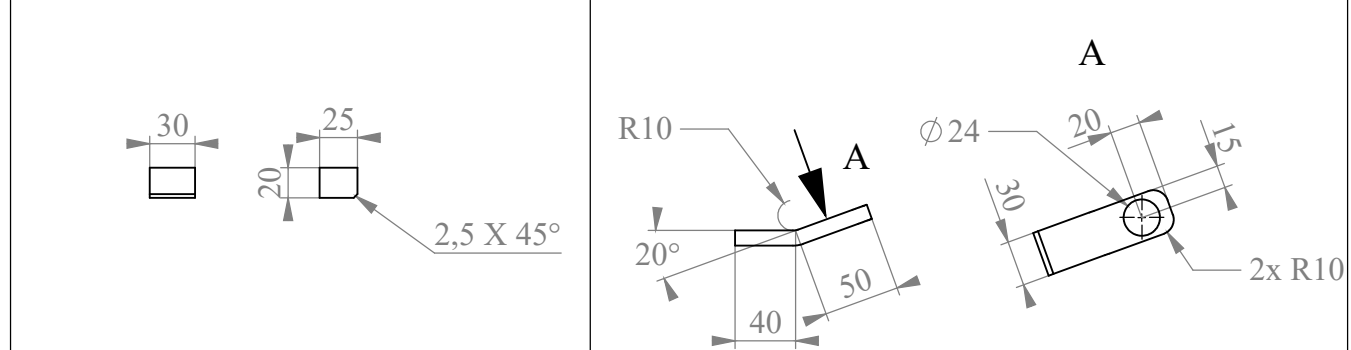

EXEPT OTHER INDICATION General tolerances to be respected : ISO 2768 : m & k Welding : v Sheet Metal : v Mould : ISO 8062 Surface texture : ISO 1302 Welding Symbols : ISO 2553	WA +10	-	20/06/2016	FX10394	Creation du document
		Mod	Date	By	Modifications
					Mass (Kg) : 2.030
					Reference Number
					Pédale
					Rev : -
					Drawing Number
					DTM Class : 2-01-07 DTE Class : ... D3 Sheet : 1/1
					Size : A3 Scale : 1:5 Units : mm SolidWorks 2012

Material : **Steel S235 JR or AISI 1018**

Heat treatment :
 Everywhere

Protection of surf :

21637-00836-MPE

Sheet : **1/1**