

Rev	Description	Approved - date

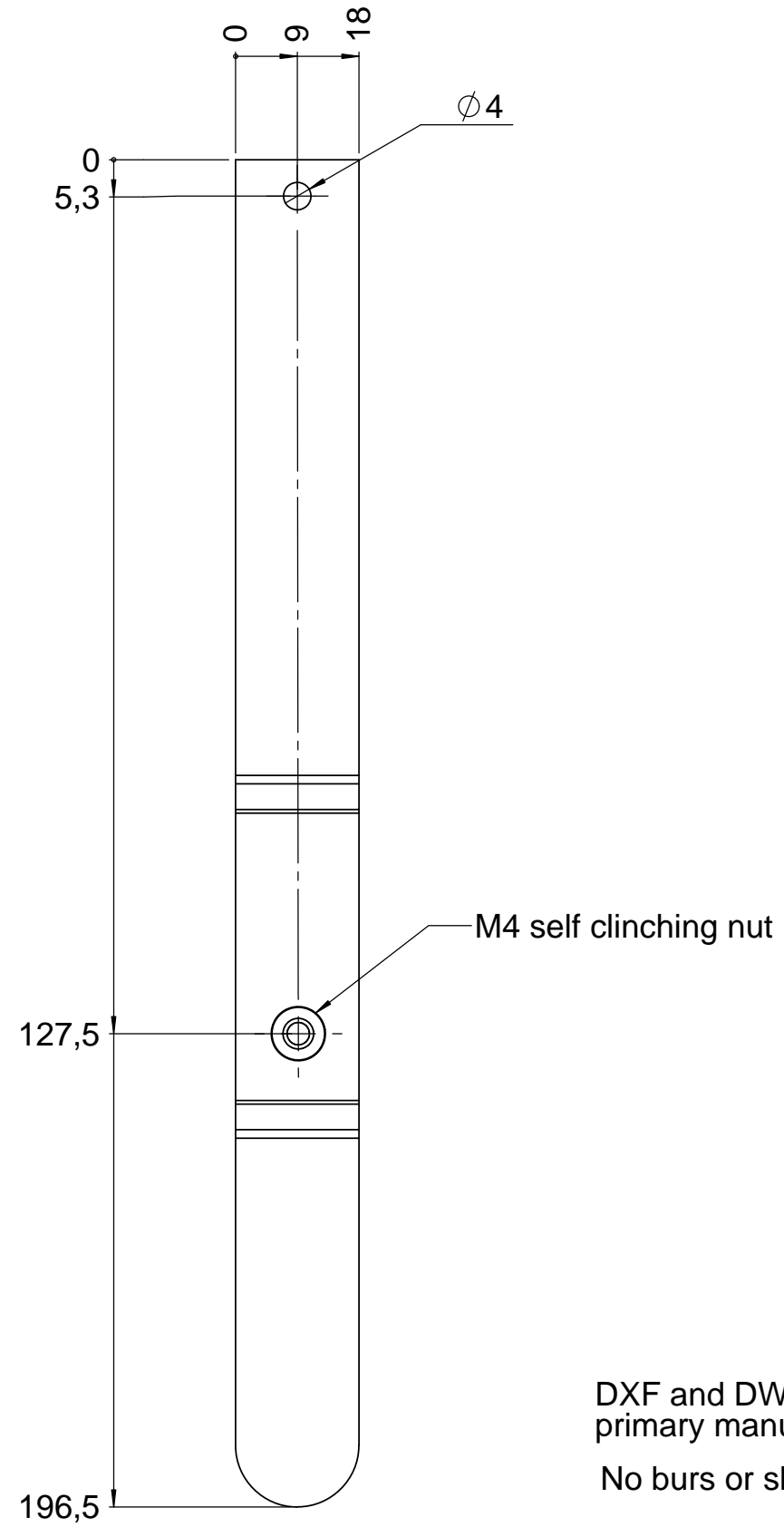
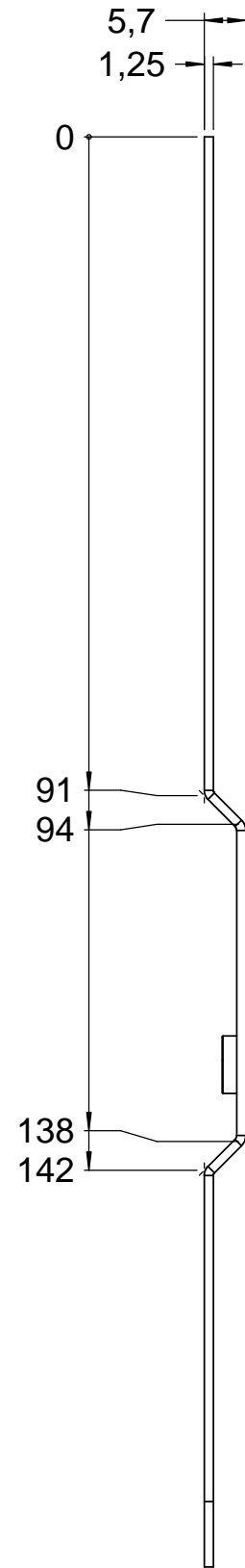

DXF and DWG file is to be used as primary manufacturing data.

No burs or sharp edges.

Material	EN 1.4310 tj=1,25mm
Finish 1	
Finish 2	
Finish 3	

Documentname		Handle StarStove 140806		Tolerance		SS-ISO 2768 - 1 m		Projection		Scale (A3)	
Drawn - Date	ArHa	2014-08-20	Approved - date								
Client				Description							
				Handle StarStove							
				Art.nr				Rev		Sheet	
								1		1 of 1	

