

Material :
Steel S235 JR or AISI 1018

Heat treatment :
 Everywhere

Protection of surf :

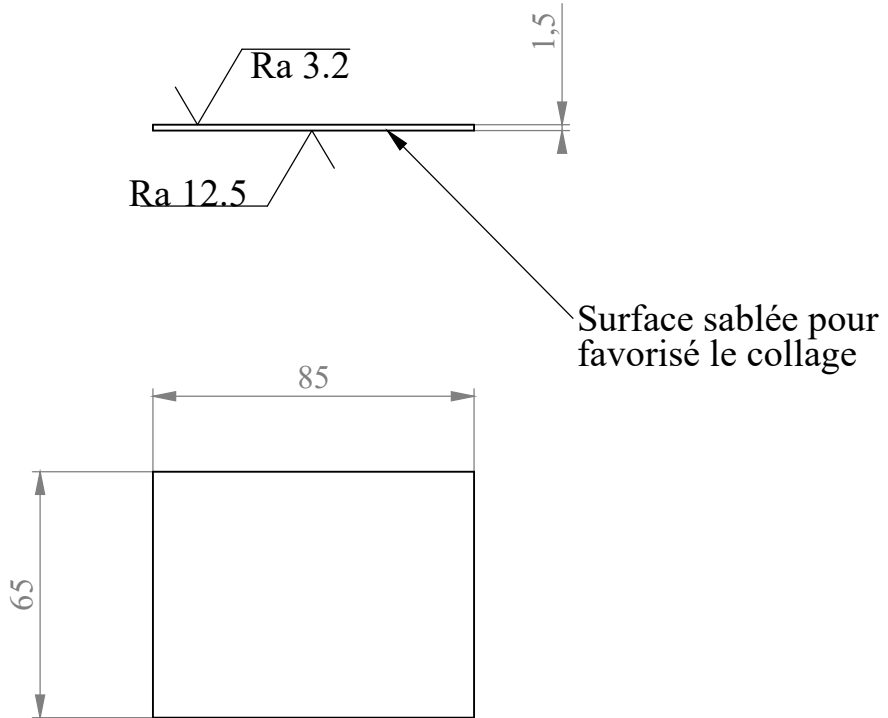
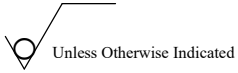

Casser les angles vifs / Remove sharp edges

EXEPT OTHER INDICATION

General tolerances to be respected :
 ISO 2768 : m & k
 Welding : v
 Sheet Metal : v
 Mould : ISO 8062
 Surface texture : ISO 1302
 Welding Symbols : ISO 2553

WA +10

- 20/06/2016 FX10394 Creation du document

Mod	Date	By	Modifications

Mass (Kg) :

0.065

Reference Number

CAUTION :
 All dimensions are in millimeters and projected view in ISO std

**Tole de protection
 pour pédale**

21637-00835-MPE

Rev :

-

Drawing Number

DTM Class : 2-01-07

DTE Class : ...

D3

Sheet :

Size : A4

Scale : 1:2

Units : mm

SolidWorks 2012

1/1