

Item	Qty	Reference	Description	Obs
1	1	R-21637-00836-MPE	Pédale	
2	2	R-21637-00835-MPE	Toile de protection pour pédale	
3	1	R-21637-00834-MPE	Capot de protection	
4	1	R-21637-00832-MPE	Support Pédales	
5	2	C-BMA42-37304-COM	Pédale de relance a 1 cran (2 positions)	
6	4	C-BMA42-30222-COM	Galvanized threaded rod. type HAS M8x80/14 + Capsule chemical	
7	2	C-00033-77397-DFP	Bille porteuse diametre 15mm charge 50daN	
8	4	C-000W3-00392-DFP	VIS F HC.M10-20.8.8	
9	8	C-000V9-5055X-DFP	vis tete fraisee a 6 pans creux E 27-160 - M 5 x 12 - 10.9	
10	2	C-000H0-07604-COM	Base iron bearing self-aligning diameter 15mm	

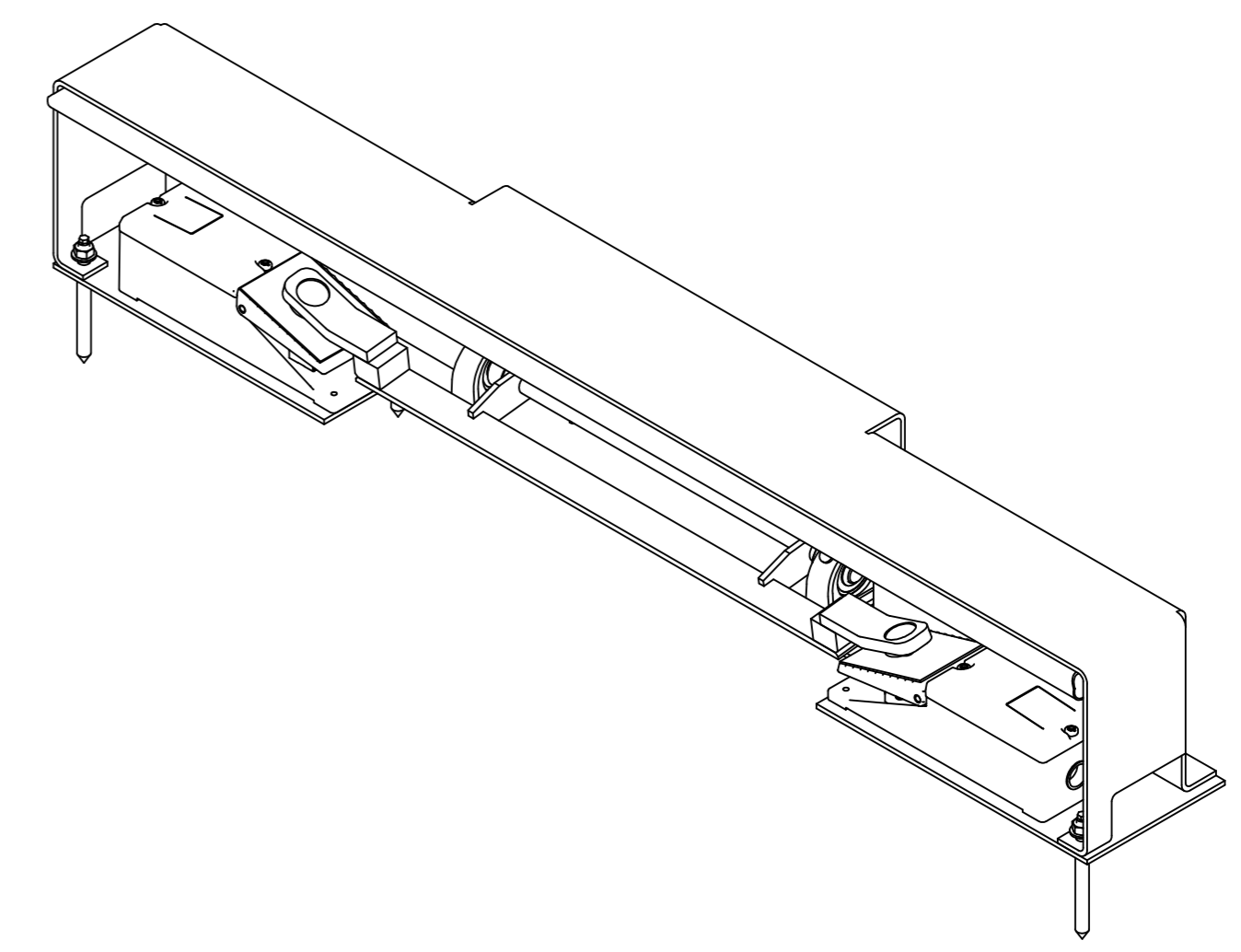

EEXPT OTHER INDICATION		WA +10		20/06/2016		FX10394		Creation du document		
General tolerances to be respected :		Mod	Date	By	Modifications					
ISO 2768 : m & k		21637-00831-MPE								Mass (Kg) :
Welding : v		Associated BOM								20
Sheet Metal : v		Reference Number								
Mould : ISO 8062		<b>Pédales de sécurité</b>								
Surface texture : ISO 1302										<b>21637-00830-MPE</b>
Welding Symbols : ISO 2553		Drawing Number								
CAUTION : All dimensions are in millimeters and projected view in ISO std		DTM Class : 2-01-06		DTE Class : 2-03		D3		Sheet : 1/1		
		Size : A2		Scale : 1:5		Units : mm		SolidWorks 2012		