

Ansicht A

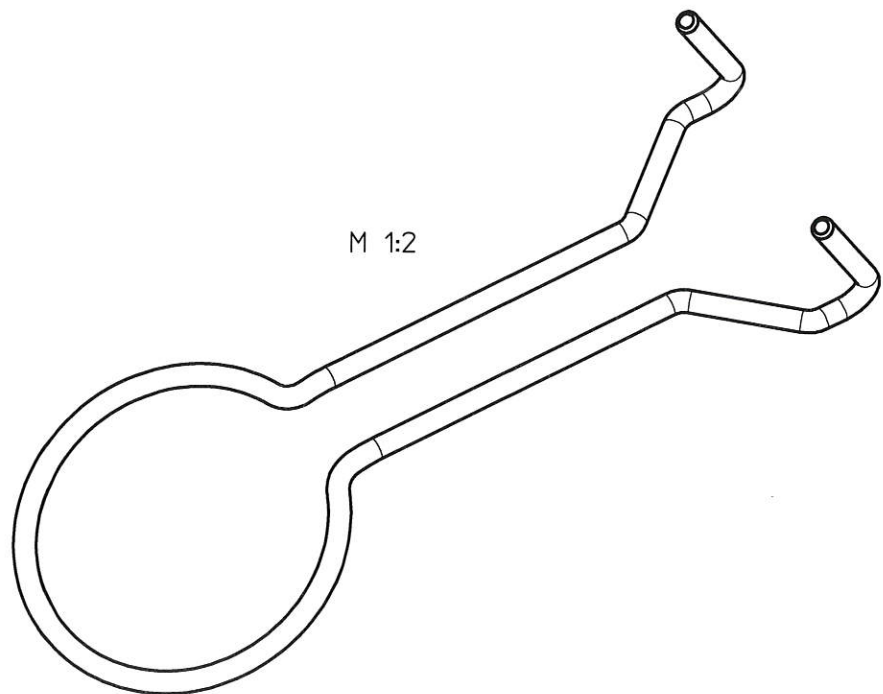
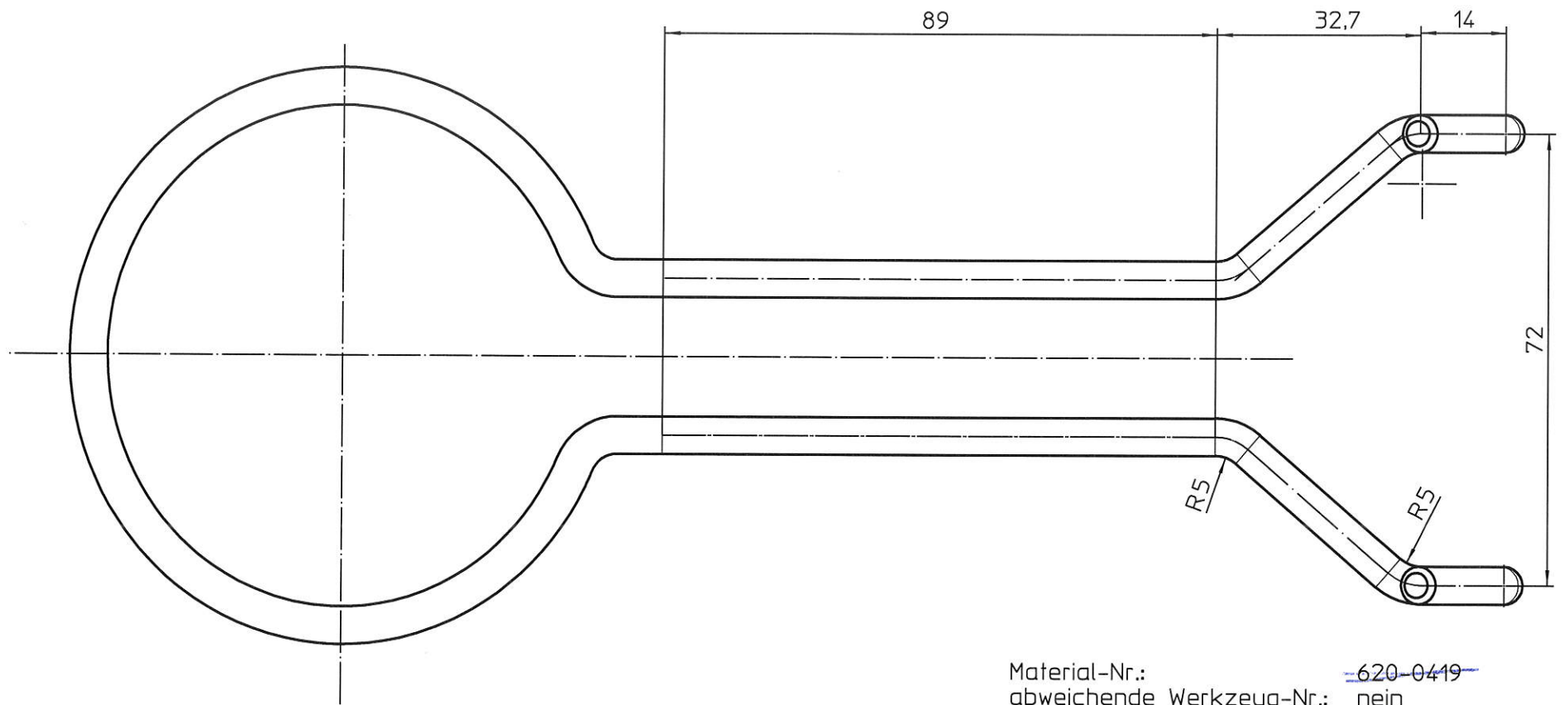
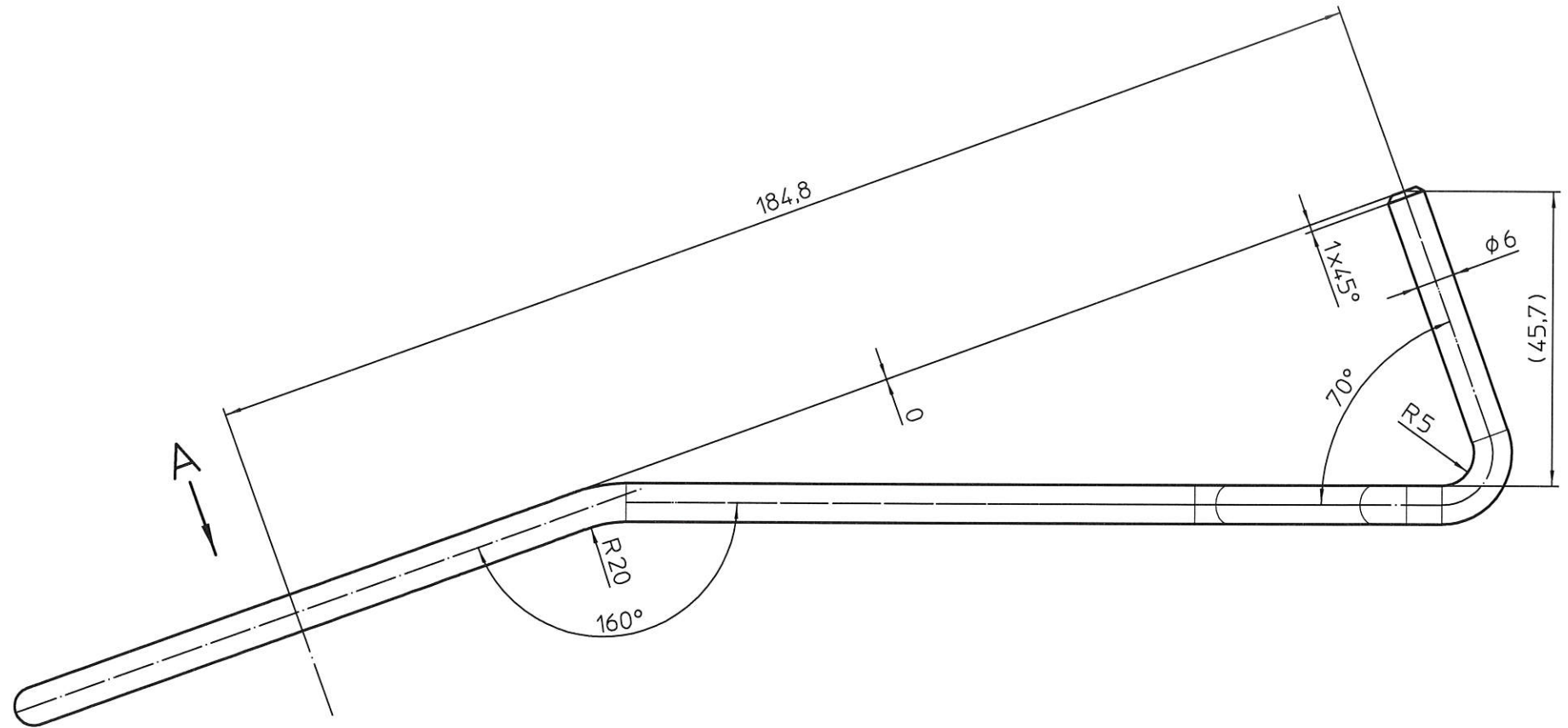
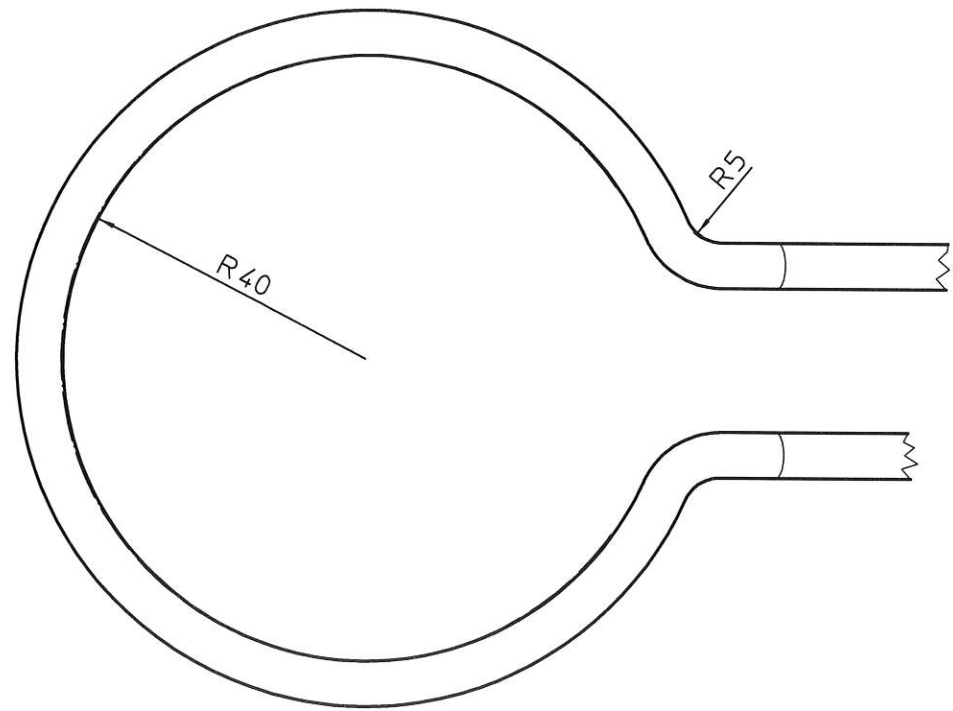

M 1:2

Material-Nr.: ~~620-0419~~
 abweichende Werkzeug-Nr.: nein
 INV-Nr.:

				Freimaßtoleranzen	Teilgewicht 151g	Werkstoff	CuZn38Pb15 weich F34	
				DIN ISO 2768-mK	Oberfläche 123cm ²		<i>Stahl (Rym) EN 10277-64M</i>	
					Vorschub	Oberflächen- behandlung	<i>verchromt EN 10277-1.0120</i>	
				Datum	Name	Maßstab	Benennung	
				Bearb. 12.12.13	astockma	1:1	Buegel Thales CM	
				Gepr. 13.01.14	dstuempe			
				Schutzvermerk ISO 16016 beachten			Zeichnungs.-Nr.	439-0571
1	MM	12.12.13	astockma	Erwin Müller Gruppe Lingen			Prüfanweisung:	<input type="checkbox"/> Maße lehren <input type="checkbox"/> Maße messen
Aus- Änderungs- gabe	Änderungs- mitteilung	Nr.	Name					