

3.2 / (1.6 /)

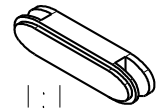
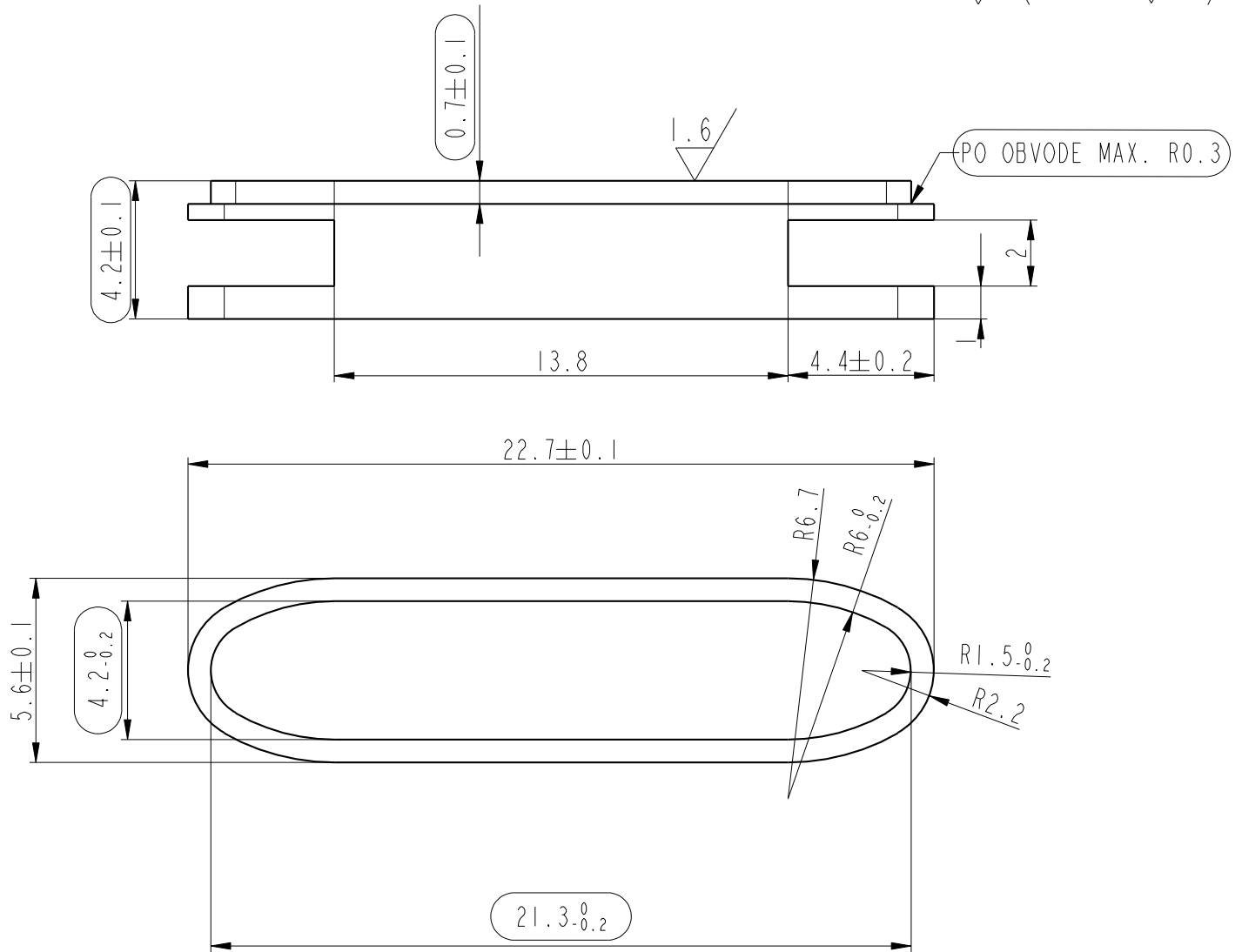

PRED OBRABANIM ZUSLACHTIT NA R_m 1000 AZ 1200 MPa (35 ± 2 HRC)
 VSEOBECNE TOLERANCIE-TRIEDA PRESNOSTI PODLA ISO 2768-mK

01-ZMENA 14/2016				26.5.2016		
Zmena				Datum		Podpis
ks	PLO 30x10 rozmer polotovaru	42CrMo4+QT material	polotovaru	hmot.	zostava	2 poz.
Format vykresu: A4		Datum	Podpis			
Modeloval:						
Kreslil:						
Technolog:						
Nazov projektu :						
Meritko:	Nazov:		Cislo vykresu:		List:1/1	
5:1	ZALISOK		115-01-01			