

14	LEXAN ZAVETRENIE	6000x1204x35				1
13	PODLOZKA	M10		DIN 125		8
12	SKRUTKA	M10x16		DIN 912		8
11	SPOJKA	PL5-328x50	EN AW-6060/AlMgSi		LIST 2	2
10	VRUT/SKRUTKA	6,3x50		DIN 7504-K		700
9	MATICA	M12		DIN 985	S PLASTOVOU VLOZKOU	42
8	PODLOZKA	M12		DIN 125-A		42
7	ZAVITOVA TYC	M12x150		DIN 976		42
6	LEXAN STRECHA 3	1477x6000x35				1
5	LEXAN STRECHA 2	5942x6000x39				1
4	LEXAN STRECHA 1	5904x6000x39				1
3	ZOSTAVA 3	5724x1507x200				1
2	ZOSTAVA 2	6000x6030x2750				1
1	ZOSTAVA 1	6000x6030x3481			LIST 3	1
PČ	NAZOV	ROZMER	MATERIAL	NORMA	POZNAMKA	KS

UNLESS OTHERWISE SPECIFIED: DIMENSIONS ARE IN MILLIMETERS SURFACE FINISH: TOLERANCES: LINEAR: ANGULAR:			FINISH:	DEBUR AND BREAK SHARP EDGES	DO NOT SCALE DRAWING	REVISION
DRAWN	NAME	SIGNATURE	DATE	TITLE:		
CHKD	csdDr		26.6.2012	ZOSTAVA		
APPVD				DWG. NO.		
MFG				SAV 01		
Q.A				MATERIAL:	A2	
				WEIGHT:	SCALE:1:100	SHEET 1 OF 61

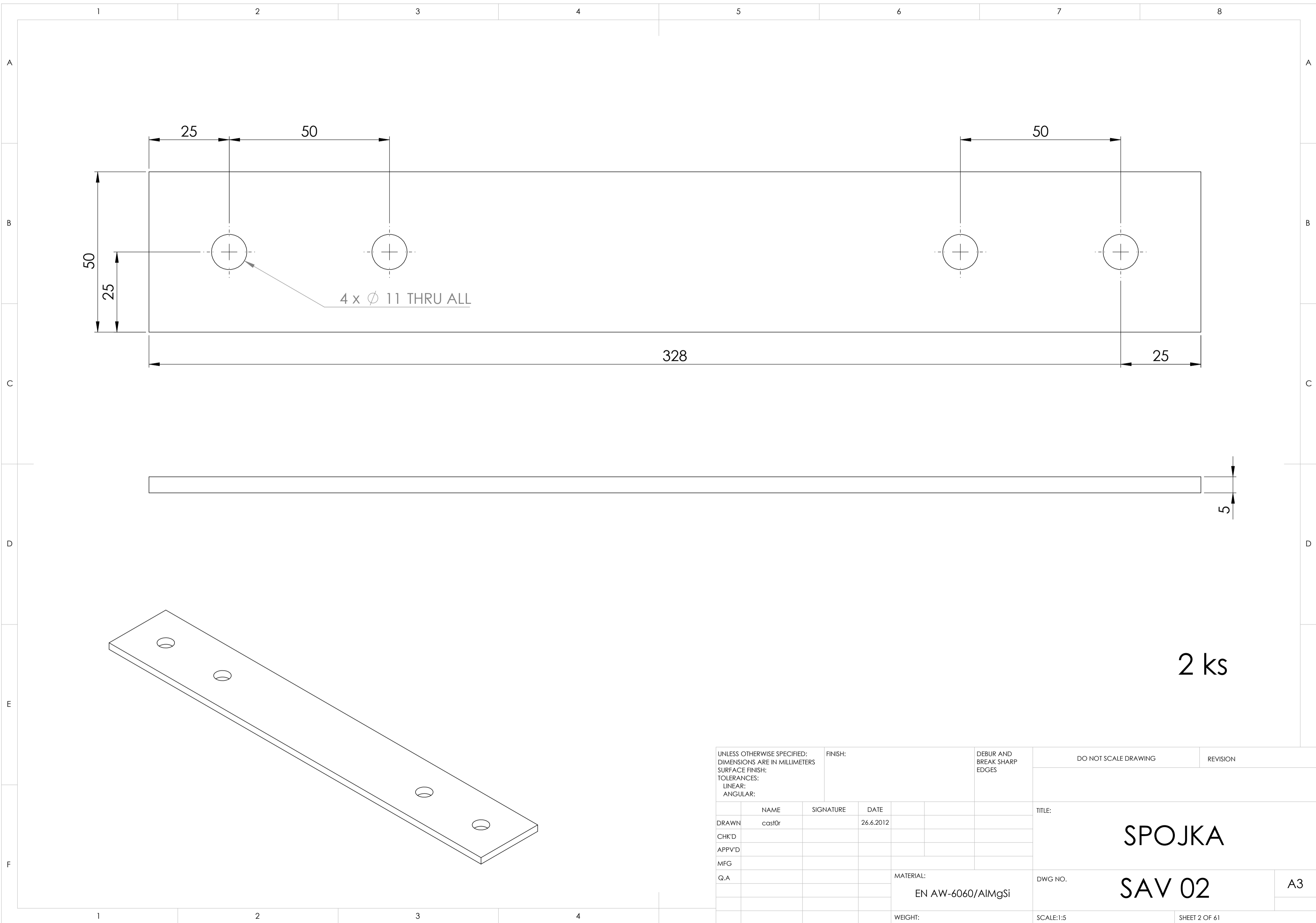

UNLESS OTHERWISE SPECIFIED: DIMENSIONS ARE IN MILLIMETERS				FINISH:		DEBUR AND BREAK SHARP EDGES		DO NOT SCALE DRAWING		REVISION	
SURFACE FINISH:											
TOLERANCES:											
LINEAR:											
ANGULAR:											
	NAME	SIGNATURE	DATE					TITLE:			
DRAWN	cast0r		26.6.2012					SPOJKA			
CHK'D											
APPV'D											
MFG											
Q.A						MATERIAL:		DWG NO.		A3	
						EN AW-6060/AlMgSi		SAV 02			
						WEIGHT:		SCALE:1:5		SHEET 2 OF 61	

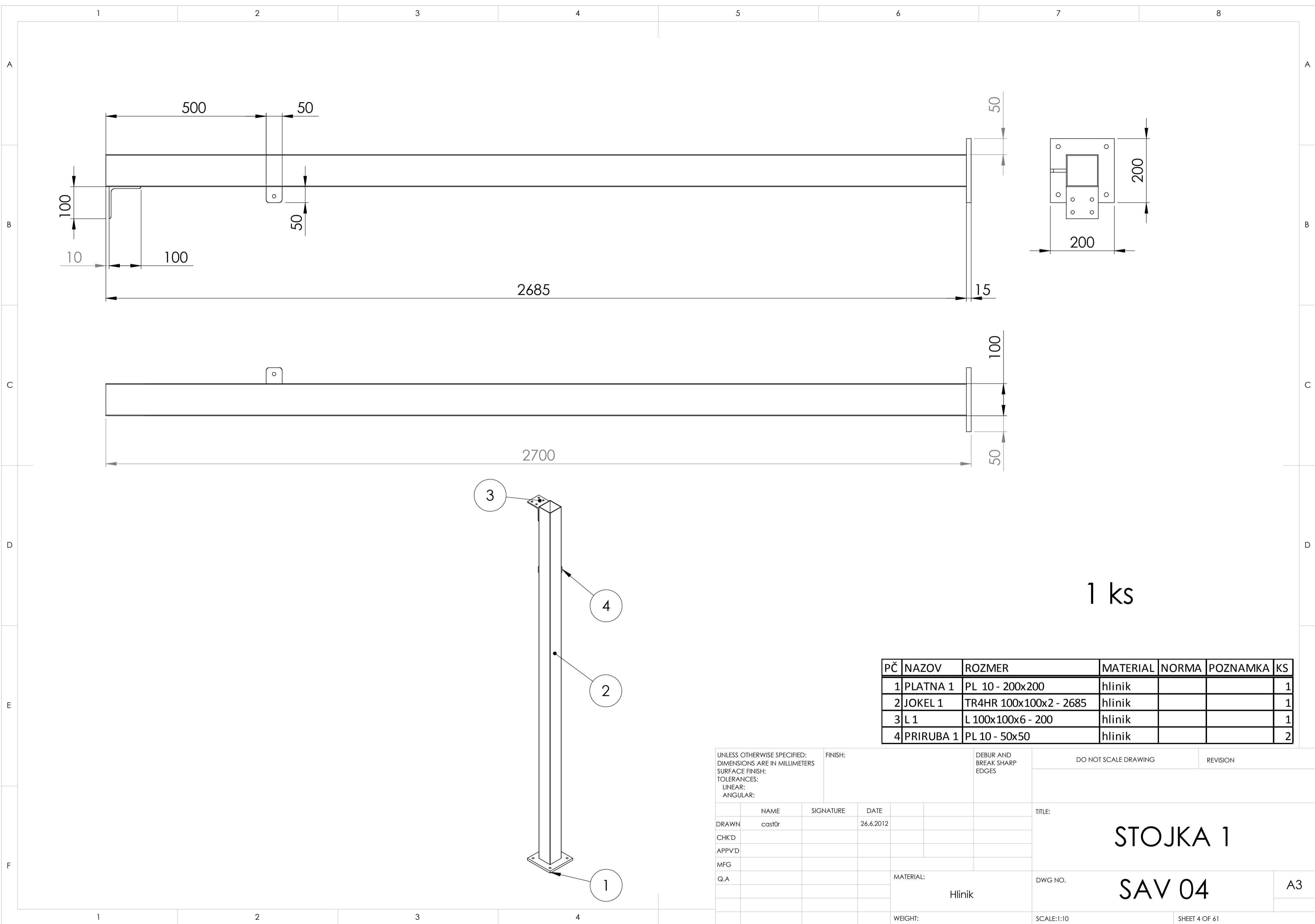

UNLESS OTHERWISE SPECIFIED: DIMENSIONS ARE IN MILLIMETERS SURFACE FINISH: TOLERANCES: LINEAR: ANGULAR:			FINISH:		DEBUR AND BREAK SHARP EDGES		DO NOT SCALE DRAWING		REVISION	
NAME	SIGNATURE	DATE							TITLE:	
DRAWN cast0r		26.6.2012							STOJKA 1	
CHK'D									DWG NO. SAV 04	
APPV'D									A3	
MFG										
Q.A					MATERIAL: Hlinik					
					WEIGHT:		SCALE:1:10		SHEET 4 OF 61	

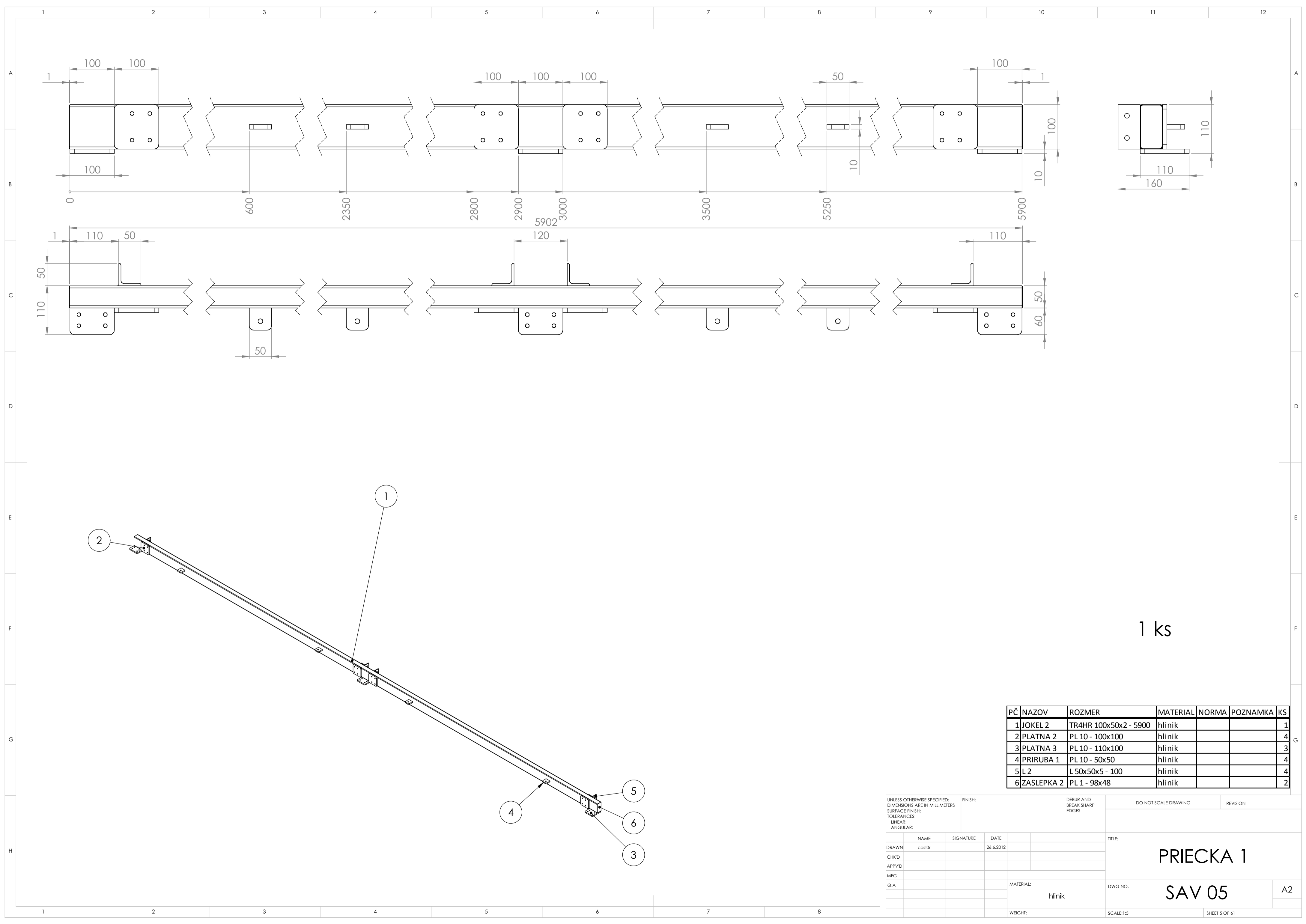

1 ks

PČ	NAZOV	ROZMER	MATERIAL	NORMA	POZNAMKA	KS
1	JOKEL 2	TR4HR 100x50x2 - 5900	hlinik			1
2	PLATNA 2	PL 10 - 100x100	hlinik			4
3	PLATNA 3	PL 10 - 110x100	hlinik			3
4	PRIRUBA 1	PL 10 - 50x50	hlinik			4
5	L 2	L 50x50x5 - 100	hlinik			4
6	ZASLEPKA 2	PL 1 - 98x48	hlinik			2

UNLESS OTHERWISE SPECIFIED: DIMENSIONS ARE IN MILLIMETERS			FINISH:		DEBUR AND BREAK SHARP EDGES		DO NOT SCALE DRAWING		REVISION	
TOLERANCES: LINEAR: ANGULAR:										
DRAWN	NAME	SIGNATURE	DATE			TITLE:				
CHK'D	cas10r		26.6.2012			PRIECKA 1				
APP'VD						DWG NO.				
MFG						SAV 05				
Q.A						SCALE:1:5		A2		
			MATERIAL:		hlinik		SHEET 5 OF 61			
			WEIGHT:							

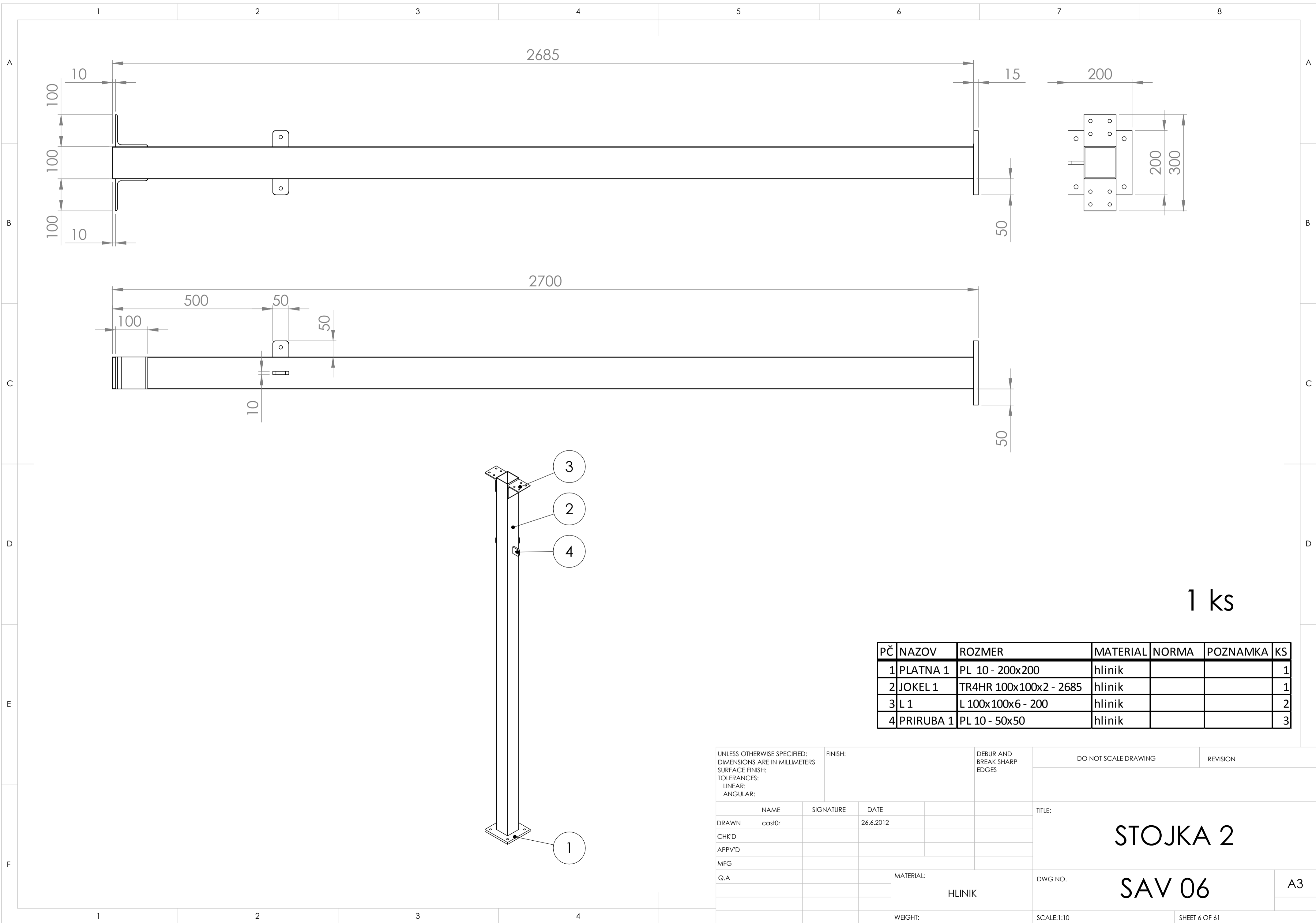

1 ks

PČ	NAZOV	ROZMER	MATERIAL	NORMA	POZNAMKA	KS
1	PLATNA 1	PL 10 - 200x200	hlinik			1
2	JOKEL 1	TR4HR 100x100x2 - 2685	hlinik			1
3	L 1	L 100x100x6 - 200	hlinik			2
4	PRIRUBA 1	PL 10 - 50x50	hlinik			3

UNLESS OTHERWISE SPECIFIED: DIMENSIONS ARE IN MILLIMETERS SURFACE FINISH: TOLERANCES: LINEAR: ANGULAR:			FINISH:		DEBUR AND BREAK SHARP EDGES		DO NOT SCALE DRAWING		REVISION	
NAME	SIGNATURE	DATE							TITLE:	
DRAWN cast0r		26.6.2012							STOJKA 2	
CHK'D									DWG NO.	
APPV'D									SAV 06	
MFG					MATERIAL: HLINIK				A3	
Q.A					WEIGHT:		SCALE:1:10		SHEET 6 OF 61	

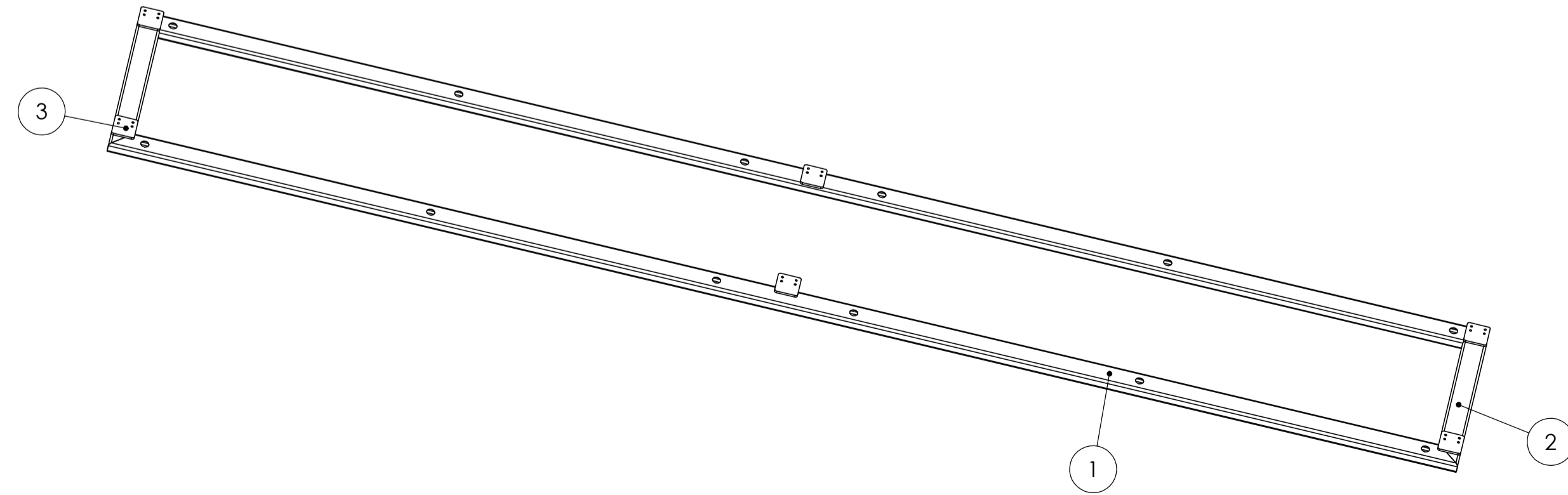
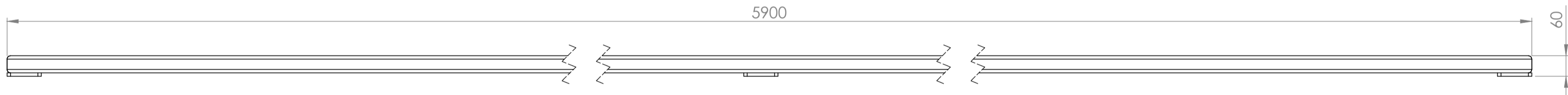
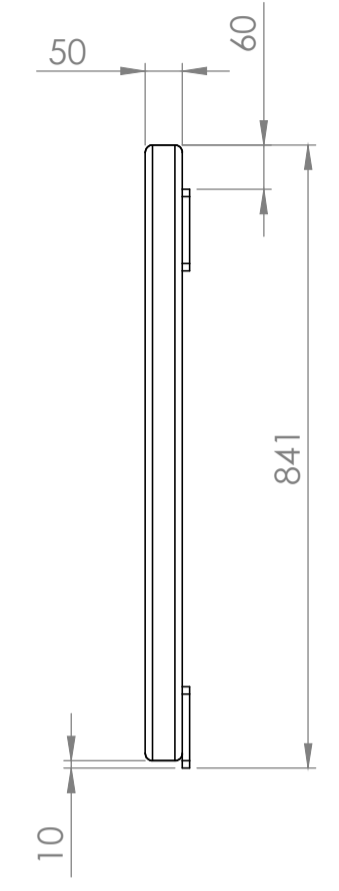
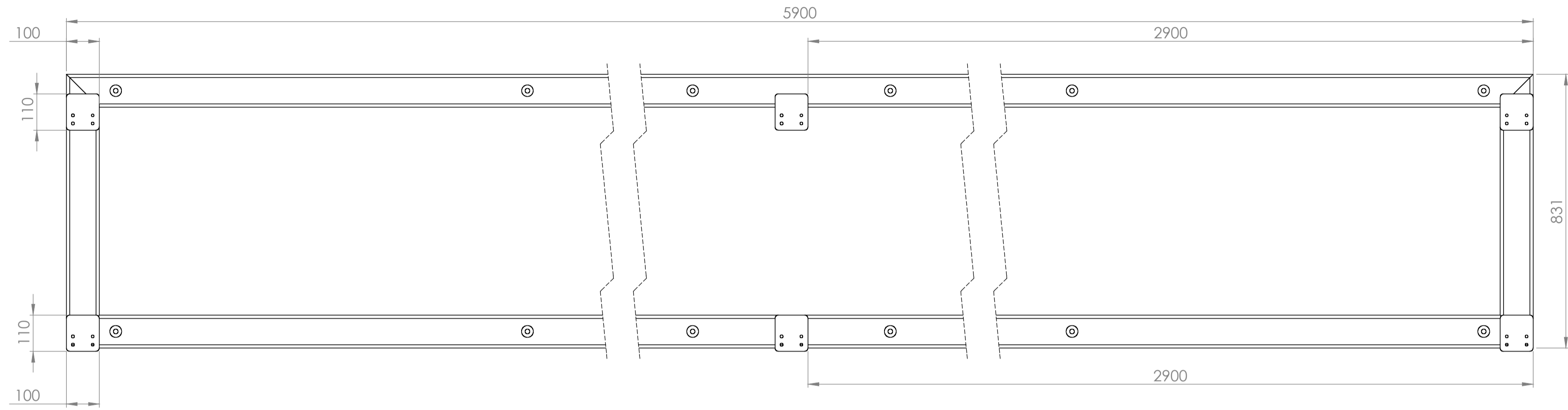

1 ks

PČ	NAZOV	ROZMER	MATERIAL	NORMA	POZNAMKA	KS
1	JOKEL 3	TR4HR 100x50x2 - 5900	hlinik			2
2	JOKEL 4	TR4HR 100x50x2 - 831	hlinik			2
3	PLATNA 3	PL 10 - 110x100	hlinik			6

UNLESS OTHERWISE SPECIFIED: DIMENSIONS ARE IN MILLIMETERS SURFACE FINISH: TOLERANCES: LINEAR: ANGULAR:			FINISH:	DEBUR AND BREAK SHARP EDGES	DO NOT SCALE DRAWING	REVISION
DRAWN cas10r	SIGNATURE	DATE 26.6.2012			TITLE: PRIECKA 2	
CHK'D					DWG NO. SAV 07	A2
APP'VD				MATERIAL: hlinik	SCALE:1:10	SHEET 7 OF 61
MFG				WEIGHT:		
Q.A						

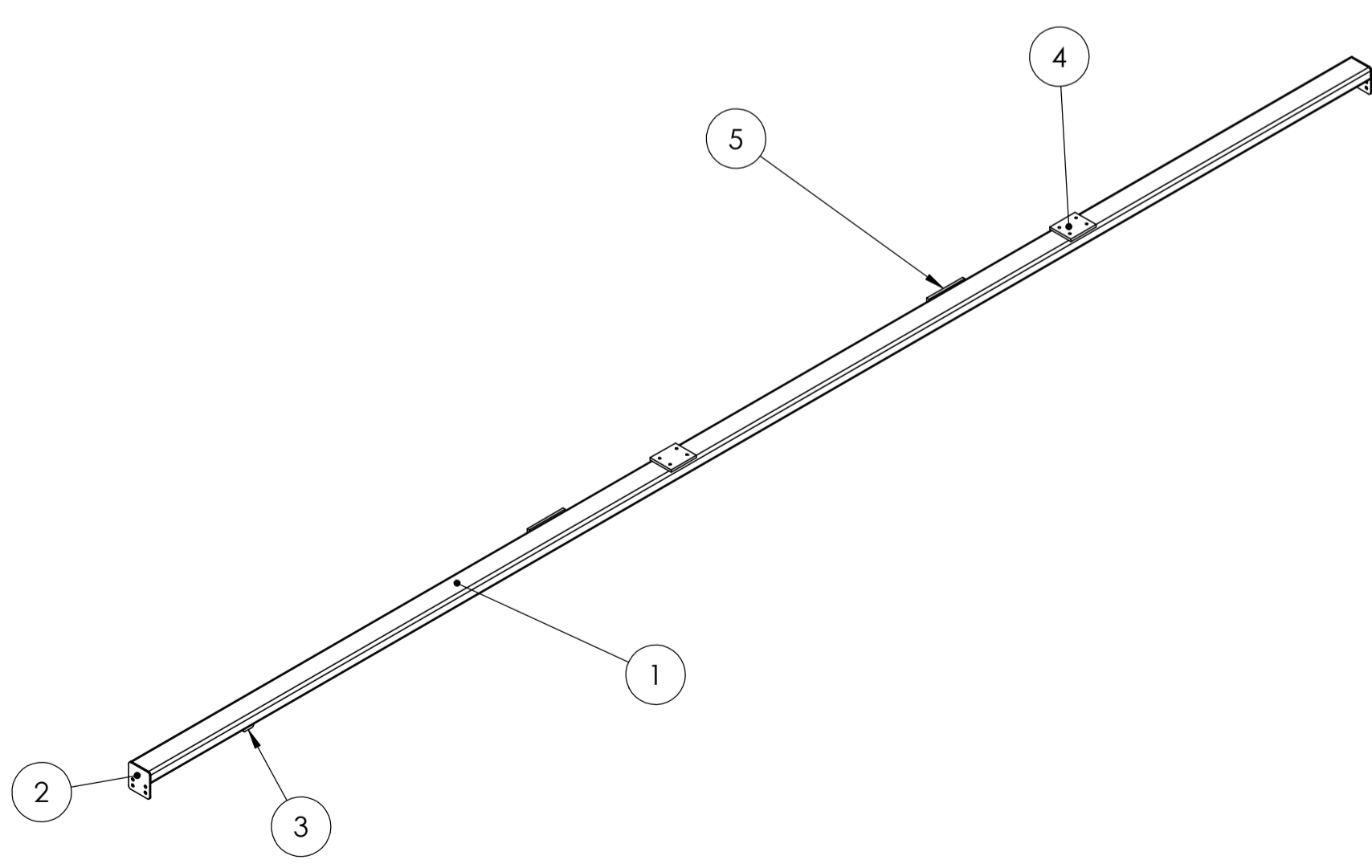
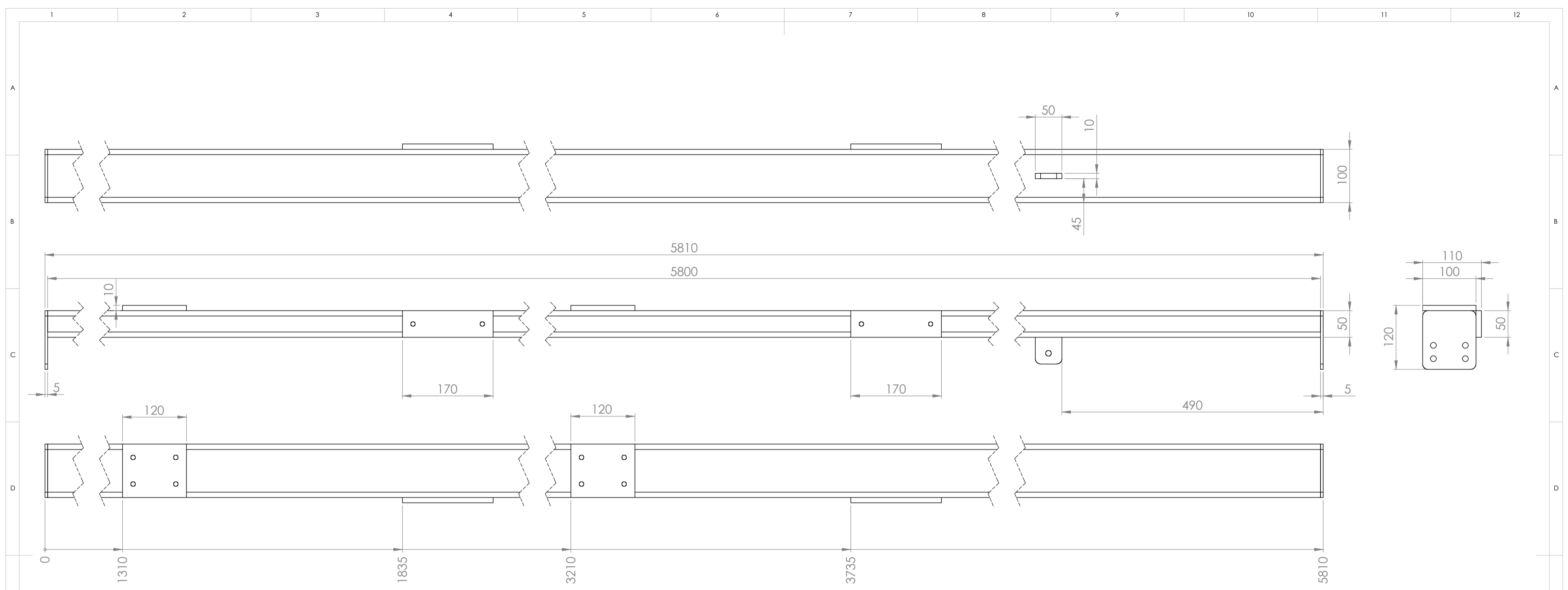

1 ks

PČ	NAZOV	ROZMER	MATERIAL	NORMA	POZNAMKA	KS
1	JOKEL 5	TR4HR 100x50x2 - 5800	hlinik			1
2	PLATNA 4	PL 10 - 110x100	hlinik			2
3	PRIRUBA 1	PL 10 - 50x50	hlinik			1
4	PLATNA 6	PL 10 - 120x100	hlinik			2
5	PLATNA 8	PL 10 - 170x50	hlinik			2

UNLESS OTHERWISE SPECIFIED: DIMENSIONS ARE IN MILLIMETERS				FINISH:		DEBUR AND BREAK SHARP EDGES		DO NOT SCALE DRAWING		REVISION	
SURFACE FINISH:				TOLERANCES:		LINEAR:		ANGULAR:		TITLE:	
DRAWN cas10r				SIGNATURE		DATE 27.6.2012				PRIECKA 3	
CHK'D										DWG NO. SAV 08	
APP'VD										SCALE:1:5	
MFG										SHEET 8 OF 61	
Q.A								MATERIAL: hlinik		A2	
								WEIGHT:			

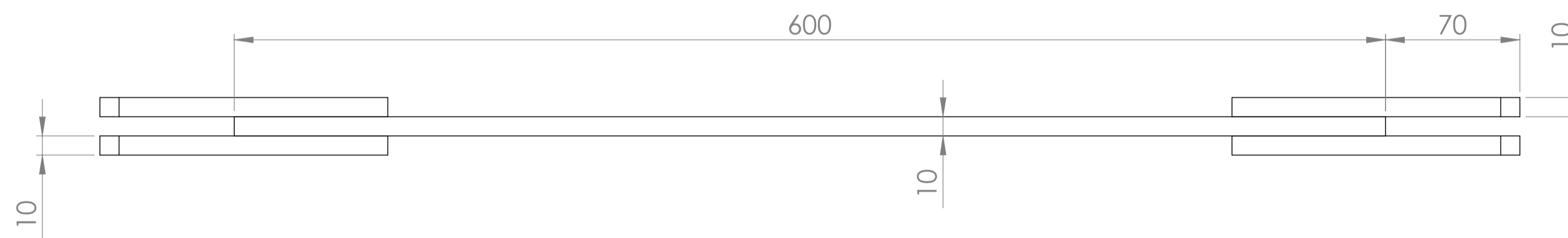
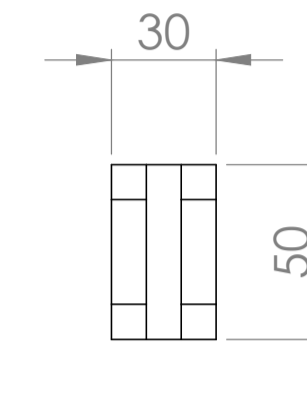
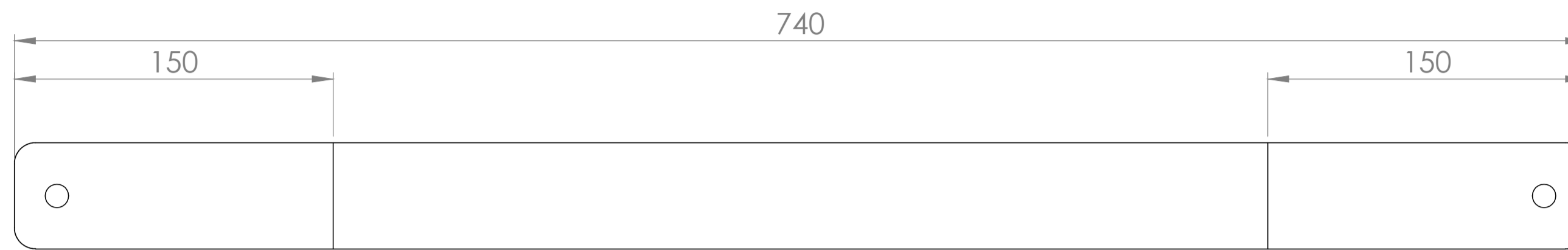

7 ks

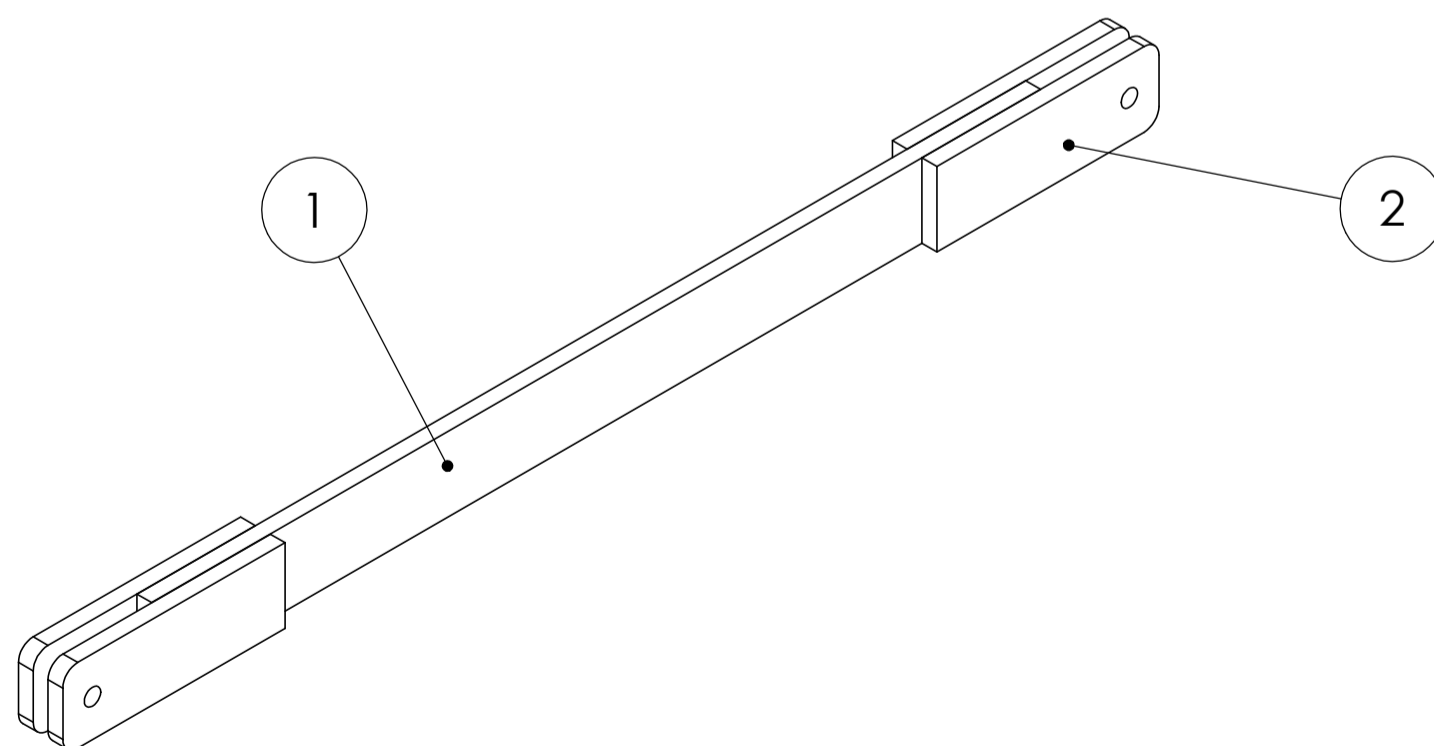

PČ	NAZOV	ROZMER	MATERIAL	NORMA	POZNAMKA	KS
1	PASOVINA 1	PL 10 - 50x600	hlinik			1
2	PRIRUBA 2	PL 10 - 50x150	hlinik			4

UNLESS OTHERWISE SPECIFIED: DIMENSIONS ARE IN MILLIMETERS SURFACE FINISH: TOLERANCES: LINEAR: ANGULAR:			FINISH:		DEBUR AND BREAK SHARP EDGES		DO NOT SCALE DRAWING		REVISION	
NAME	SIGNATURE	DATE					TITLE:			
DRAWN cast0r		27.6.2012					VYSTUHA 1			
CHK'D							DWG NO.		A3	
APPV'D							SAV 09			
MFG							SCALE:1:3		SHEET 9 OF 61	
Q.A			MATERIAL:		hlinik					
			WEIGHT:							

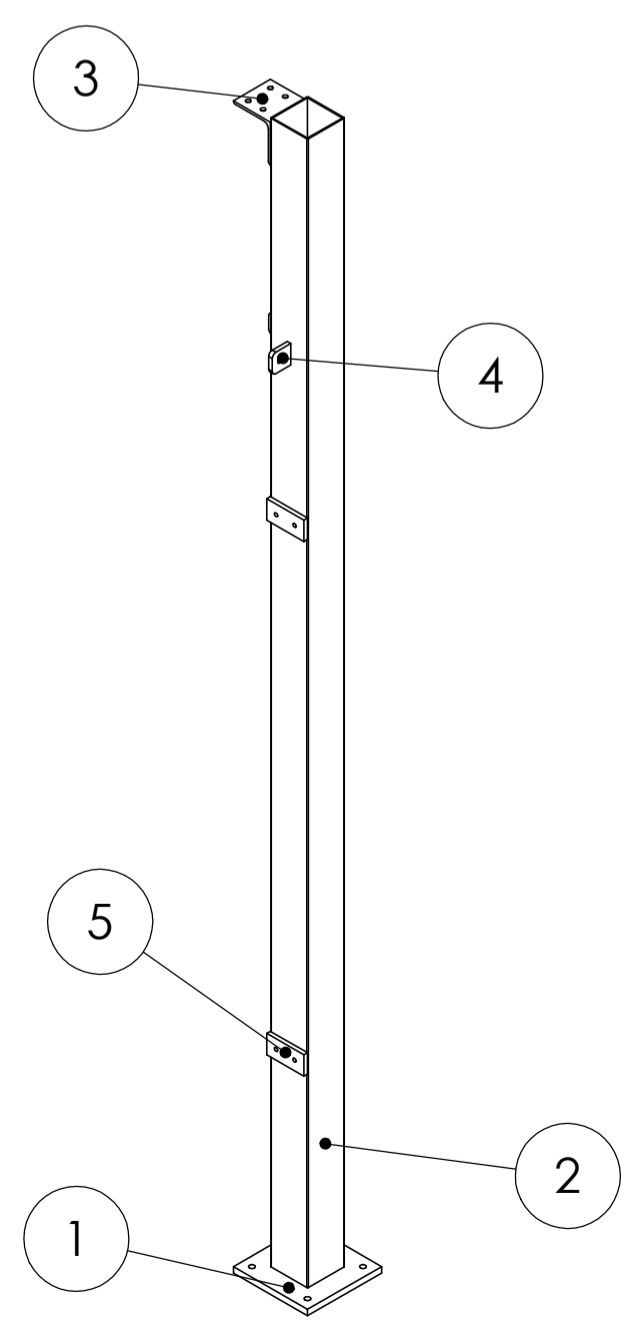
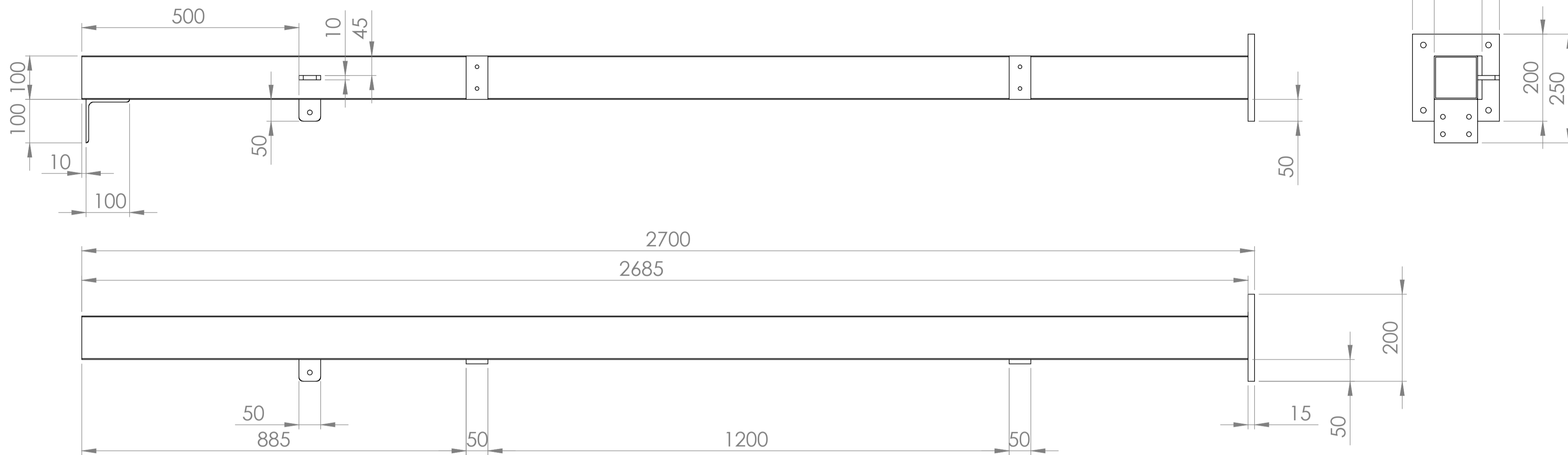

1 ks

PČ	NAZOV	ROZMER	MATERIAL	NORMA	POZNAMKA	KS
1	PLATNA 1	PL 10 - 200x200	hlinik			1
2	JOKEL 1	TR4HR 100x100x2 - 2685	hlinik			1
3	L 1	L 100x100x6 - 200	hlinik			1
4	PRIRUBA 1	PL 10 - 50x50	hlinik			2
5	PLATNA 12	PL 10 - 50x100	hlinik			2

UNLESS OTHERWISE SPECIFIED:
 DIMENSIONS ARE IN MILLIMETERS
 SURFACE FINISH:
 TOLERANCES:
 LINEAR:
 ANGULAR:

FINISH:

DEBUR AND BREAK SHARP EDGES

DO NOT SCALE DRAWING

REVISION

NAME	SIGNATURE	DATE	TITLE:
DRAWN	cast0r	27.6.2012	STOJKA 3
CHK'D			
APPV'D			
MFG			
Q.A			

MATERIAL: hlinik

DWG NO. **SAV 10**

SCALE:1:20

WEIGHT:

SHEET 10 OF 61

A3

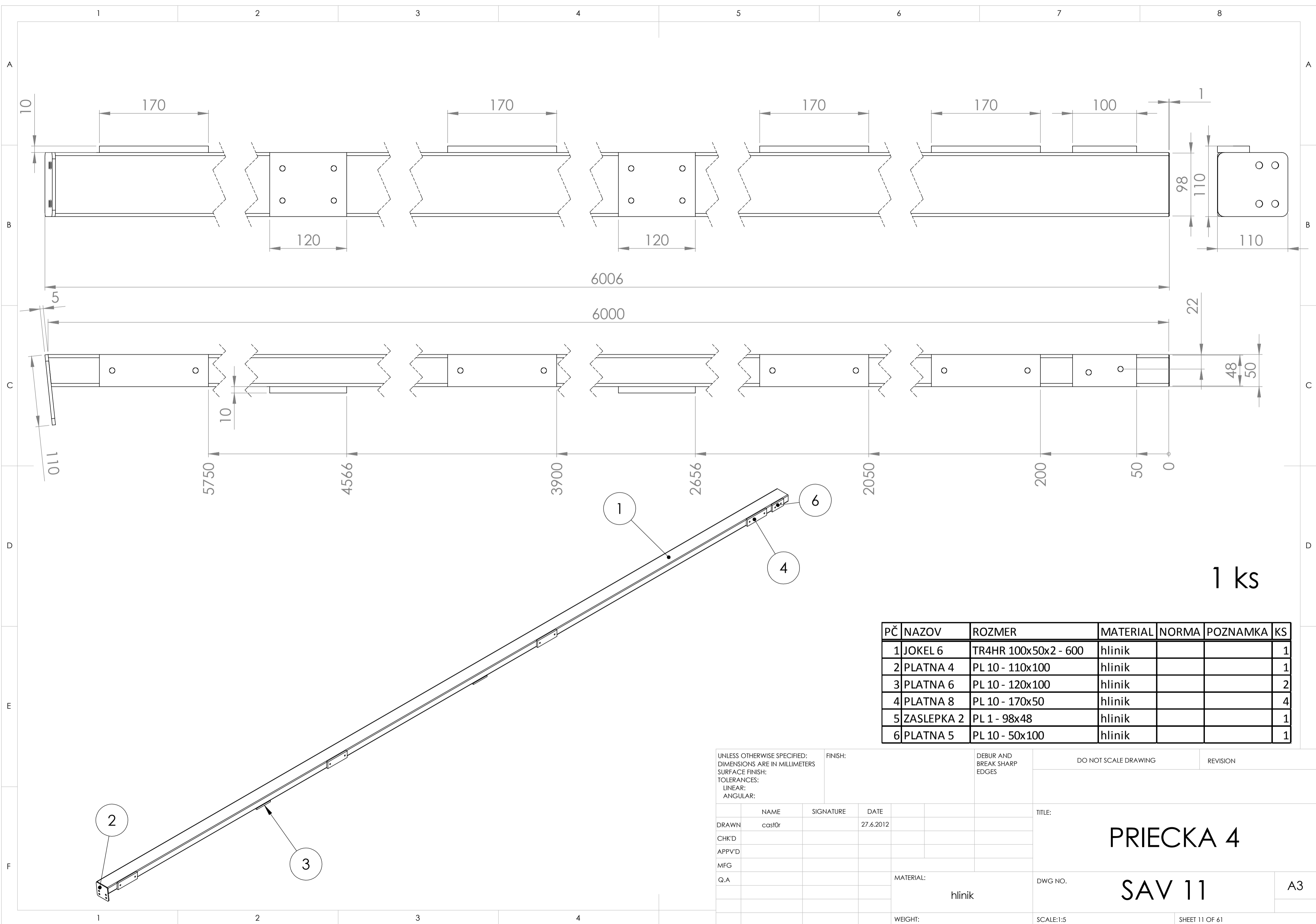

1 ks

PČ	NAZOV	ROZMER	MATERIAL	NORMA	POZNAMKA	KS
1	JOKEL 6	TR4HR 100x50x2 - 600	hlinik			1
2	PLATNA 4	PL 10 - 110x100	hlinik			1
3	PLATNA 6	PL 10 - 120x100	hlinik			2
4	PLATNA 8	PL 10 - 170x50	hlinik			4
5	ZASLEPKA 2	PL 1 - 98x48	hlinik			1
6	PLATNA 5	PL 10 - 50x100	hlinik			1

UNLESS OTHERWISE SPECIFIED:
 DIMENSIONS ARE IN MILLIMETERS
 SURFACE FINISH:
 TOLERANCES:
 LINEAR:
 ANGULAR:

FINISH:

DEBUR AND
 BREAK SHARP
 EDGES

DO NOT SCALE DRAWING

REVISION

NAME	SIGNATURE	DATE	TITLE:
DRAWN	cast0r	27.6.2012	PRIECKA 4
CHK'D			
APPV'D			
MFG			
Q.A			

MATERIAL: hlinik

DWG NO. **SAV 11**

SCALE:1:5

WEIGHT:

SHEET 11 OF 61

A3

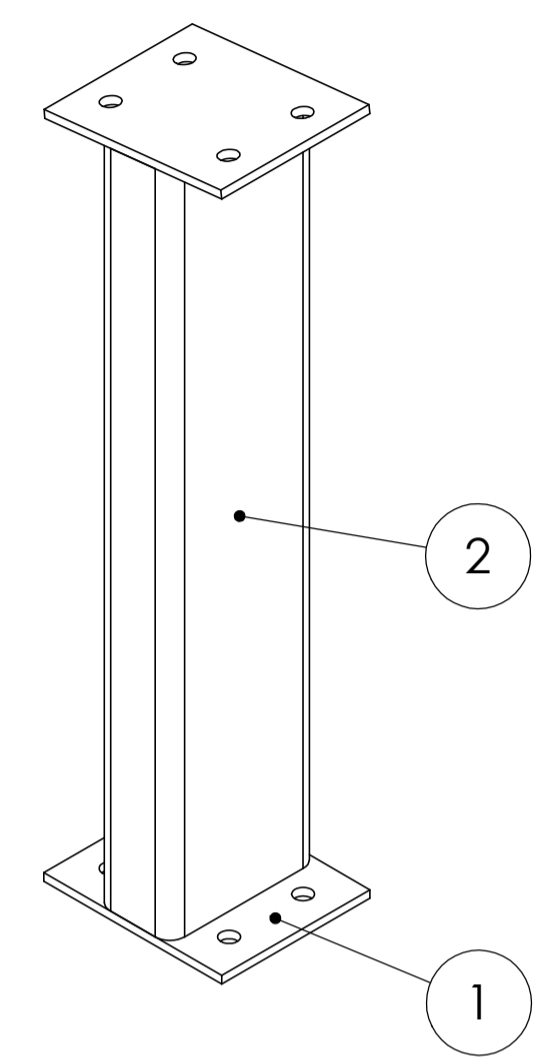
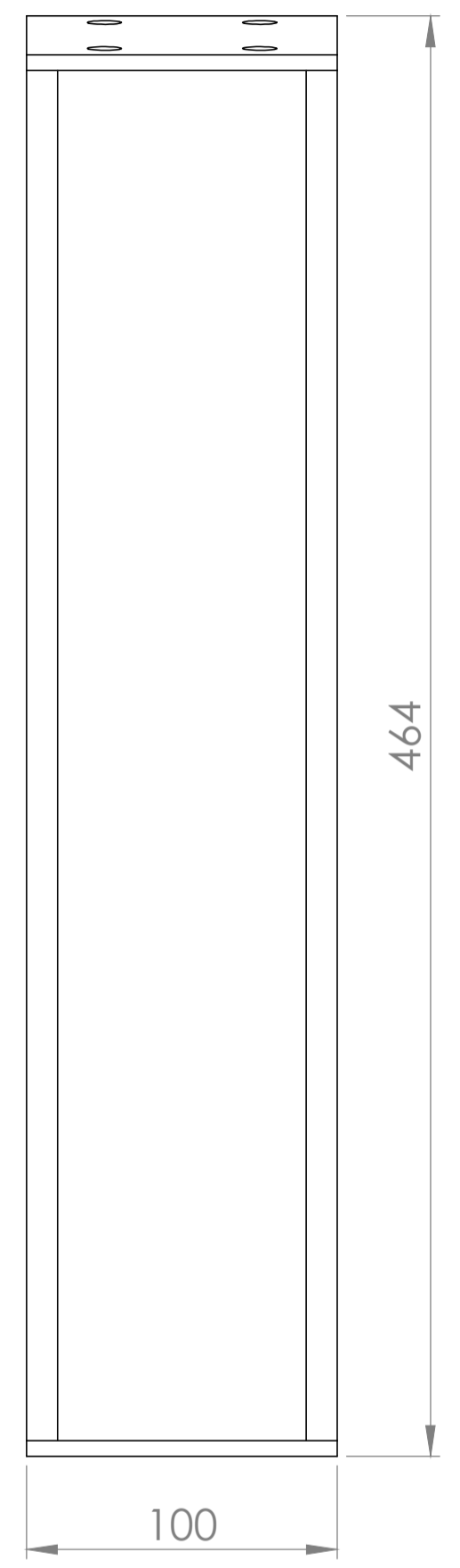
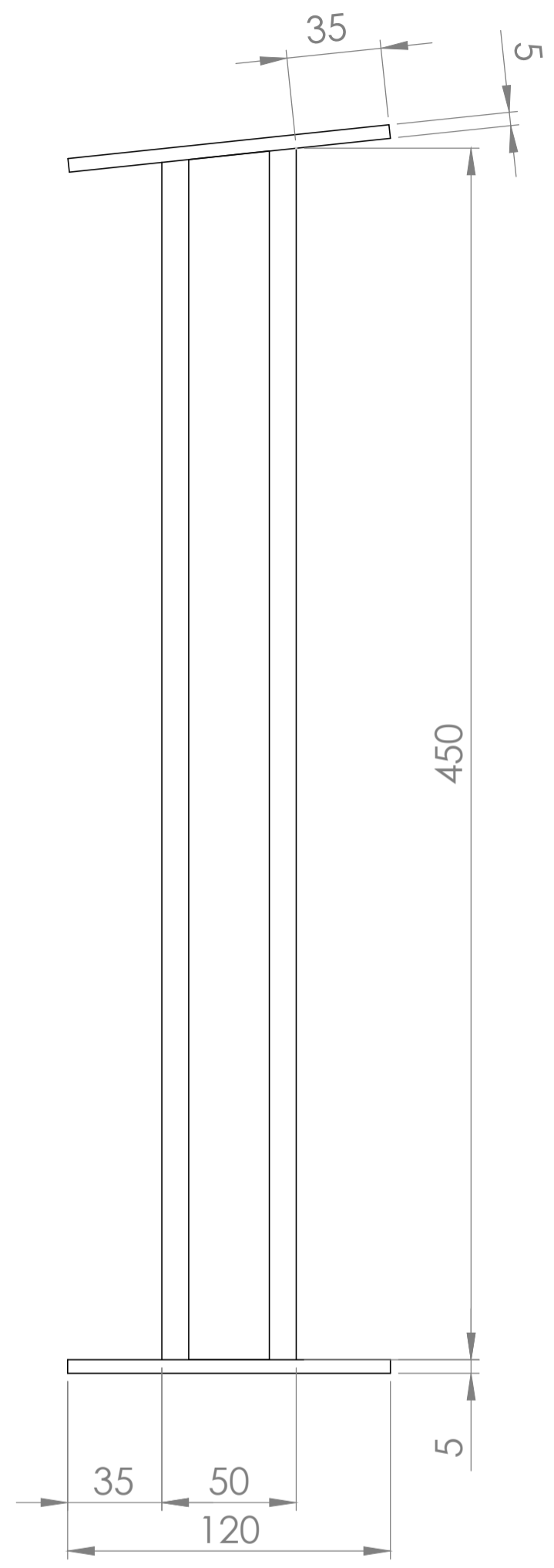

3 ks

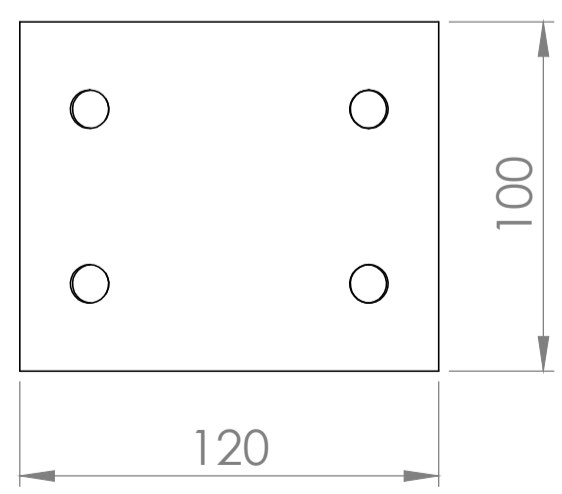

PČ	NAZOV	ROZMER	MATERIAL	NORMA	POZNAMKA	KS
1	PLATNA 7	PL 5 - 100x120	hlinik			2
2	JOKEL 7	TR4HR 100x50x2 - 450	hlinik			1

UNLESS OTHERWISE SPECIFIED: DIMENSIONS ARE IN MILLIMETERS SURFACE FINISH: TOLERANCES: LINEAR: ANGULAR:			FINISH:		DEBUR AND BREAK SHARP EDGES		DO NOT SCALE DRAWING		REVISION		
NAME	SIGNATURE	DATE					TITLE: VYSTUHA 2				
DRAWN cast0r		27.6.2012					DWG NO. SAV 12				
CHK'D							SCALE:1:3				
APPV'D							SHEET 12 OF 61				
MFG							A3				
Q.A			MATERIAL: hlinik								
			WEIGHT:								

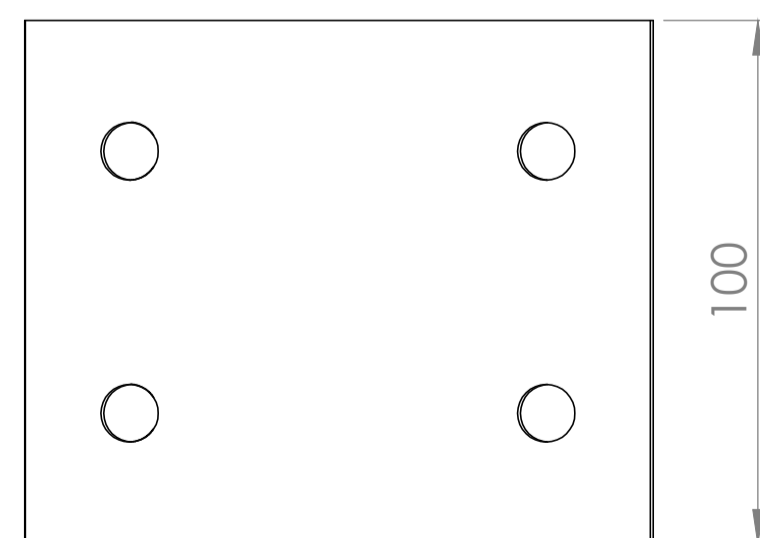
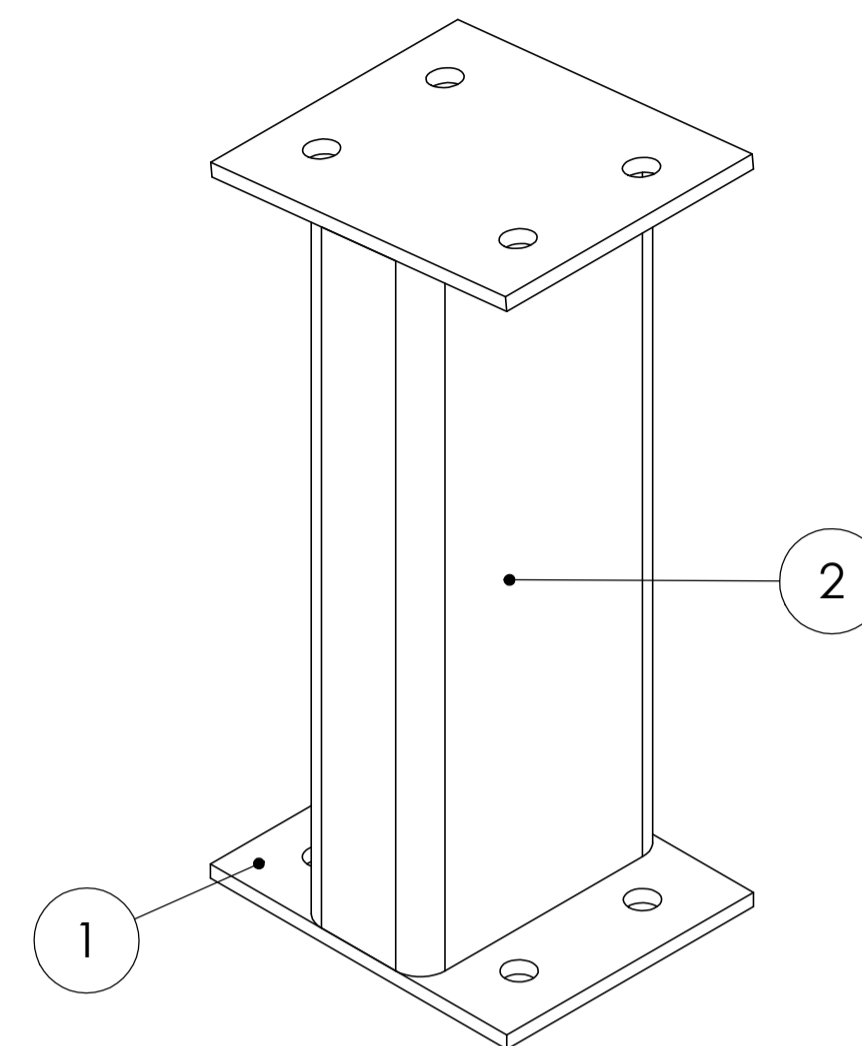
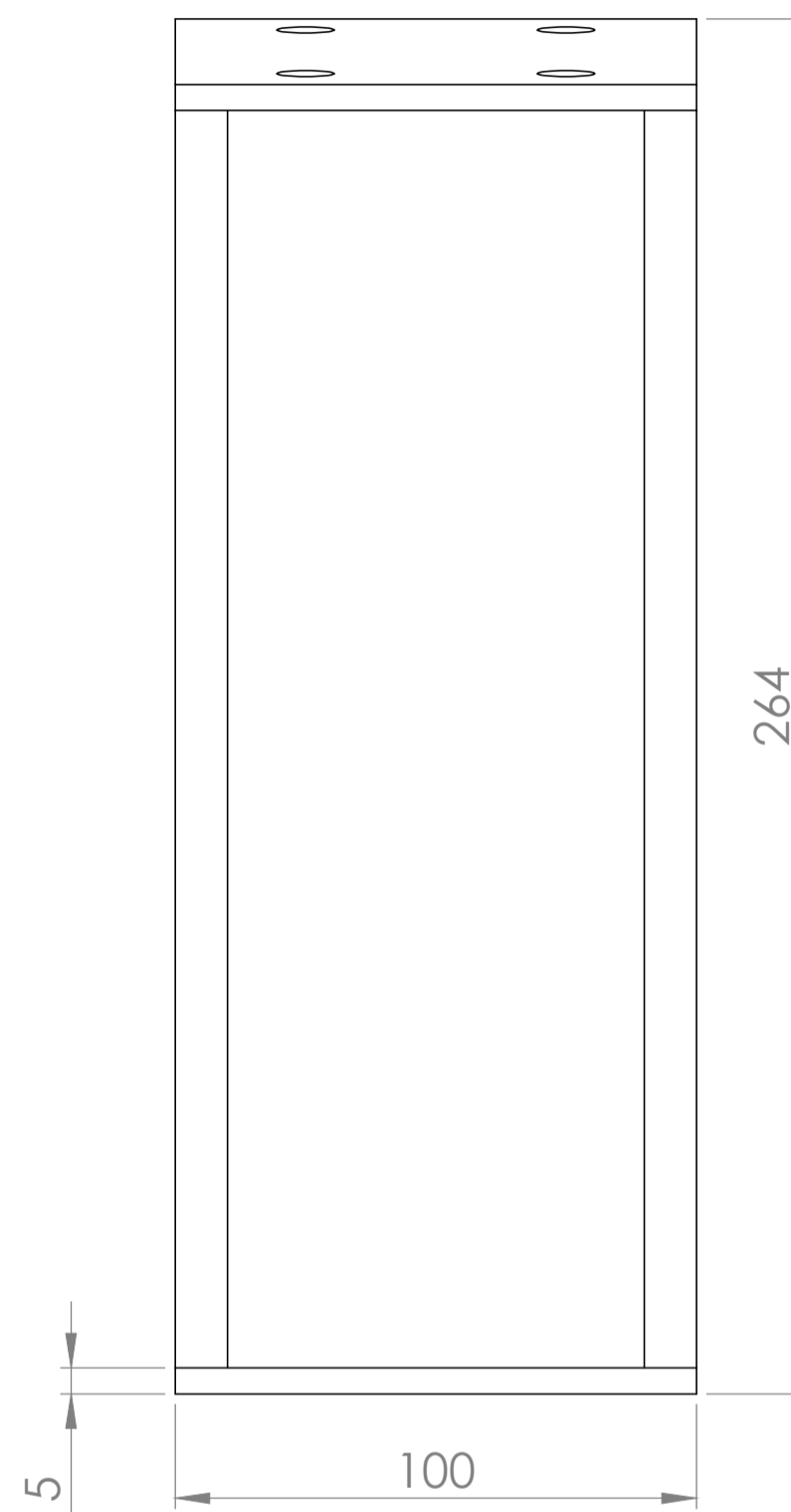
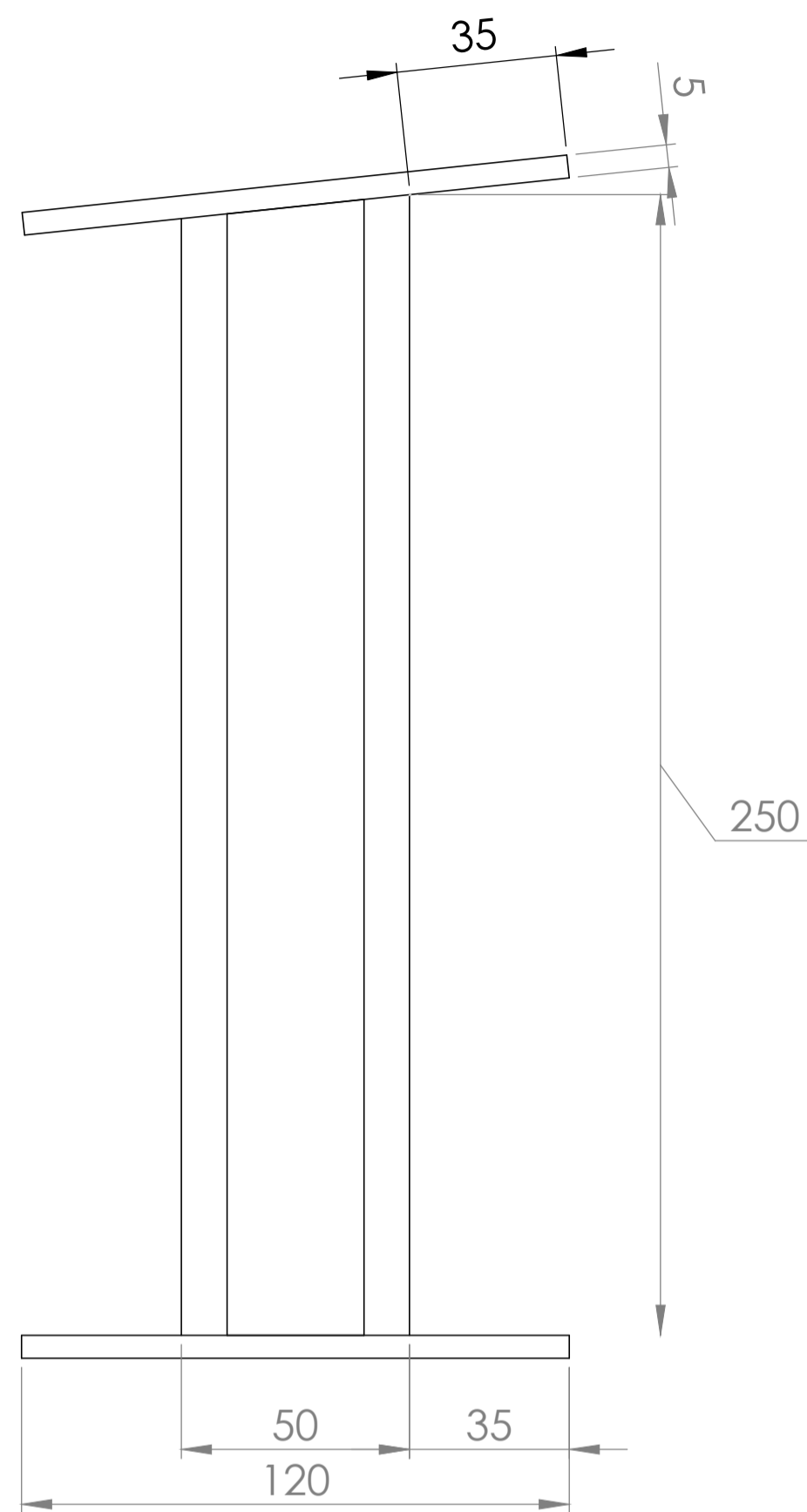

3 ks

PČ	NAZOV	ROZMER	MATERIAL	NORMA	POZNAMKA	KS
1	PLATNA 7	PL 5 - 100x120	hlinik			2
2	JOKEL 8	TR4HR 100x50x2 - 250	hlinik			1

UNLESS OTHERWISE SPECIFIED: DIMENSIONS ARE IN MILLIMETERS SURFACE FINISH: TOLERANCES: LINEAR: ANGULAR:			FINISH:		DEBUR AND BREAK SHARP EDGES		DO NOT SCALE DRAWING		REVISION			
NAME	SIGNATURE	DATE				TITLE:		<h1>VYSTUHA 3</h1>				
DRAWN	cast0r	27.6.2012				DWG NO.					<h2>SAV 13</h2>	
CHK'D						SCALE:1:2						
APPV'D						SHEET 13 OF 61						
MFG												
Q.A			MATERIAL:		hlinik							
			WEIGHT:									

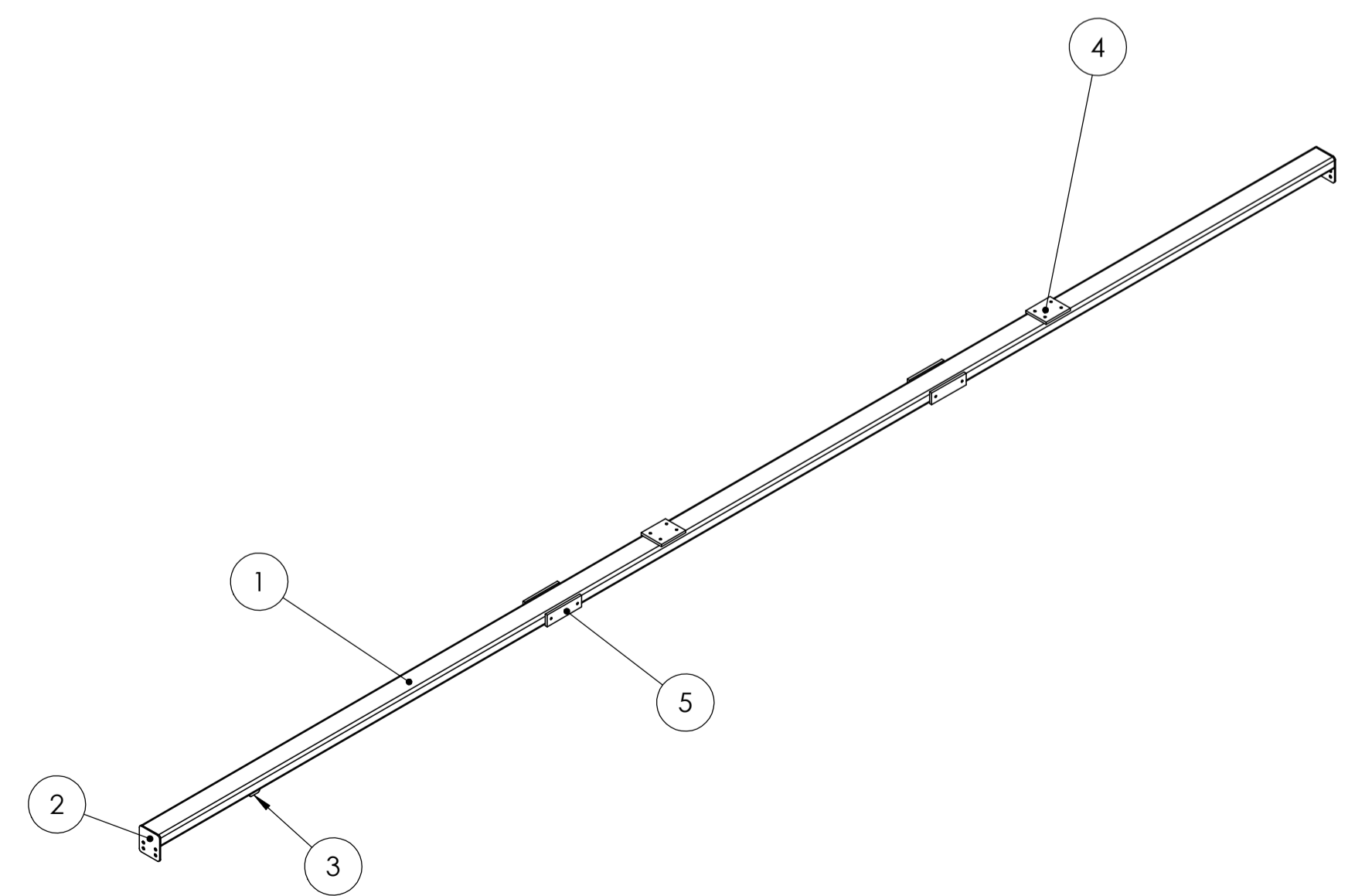
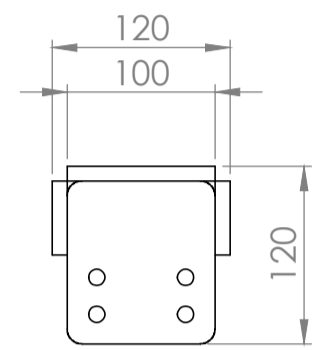
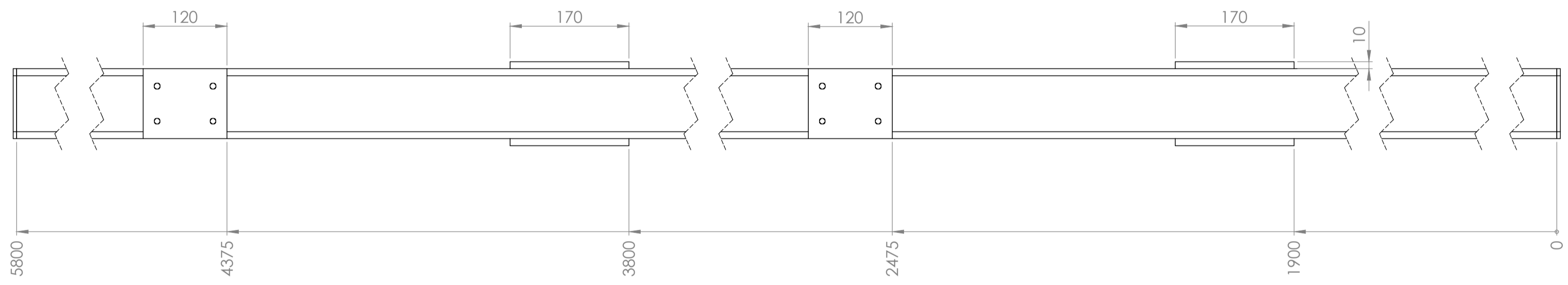
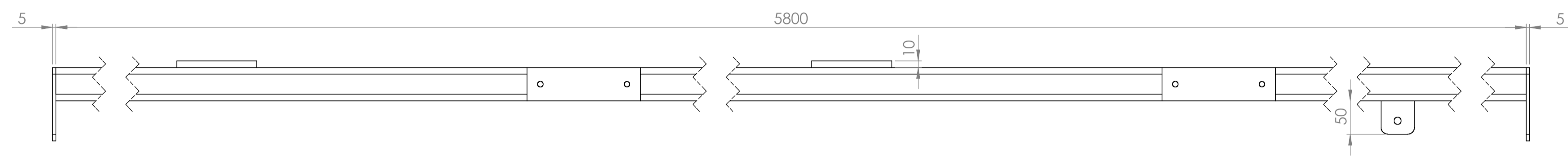
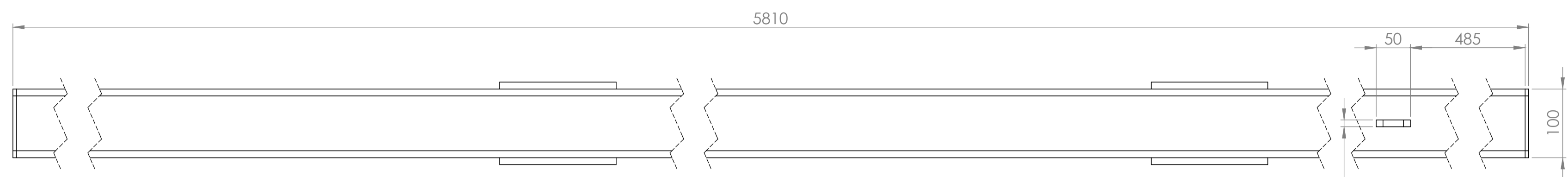

1 ks

PC	NAZOV	ROZMER	MATERIAL	NORMA	POZNAMKA	KS
1	JOKEL 5	TR4HR 100x50x2 - 5800	hlinik			1
2	PLATNA 4	PL 10 - 110x100	hlinik			2
3	PRIRUBA 1	PL 10 - 50x50	hlinik			1
4	PLATNA 6	PL 10 - 120x100	hlinik			2
5	PLATNA 8	PL 10 - 170x50	hlinik			4

UNLESS OTHERWISE SPECIFIED:
 DIMENSIONS ARE IN MILLIMETERS
 SURFACE FINISH:
 TOLERANCES:
 LINEAR:
 ANGULAR:

FINISH:

DEBUR AND BREAK SHARP EDGES

DO NOT SCALE DRAWING

REVISION

TITLE:

PRIECKA 3a

DWG NO. **SAV 14**

SCALE:1:5

SHEET 14 OF 61

A2

1 2 3 4 5 6 7 8 9 10 11 12

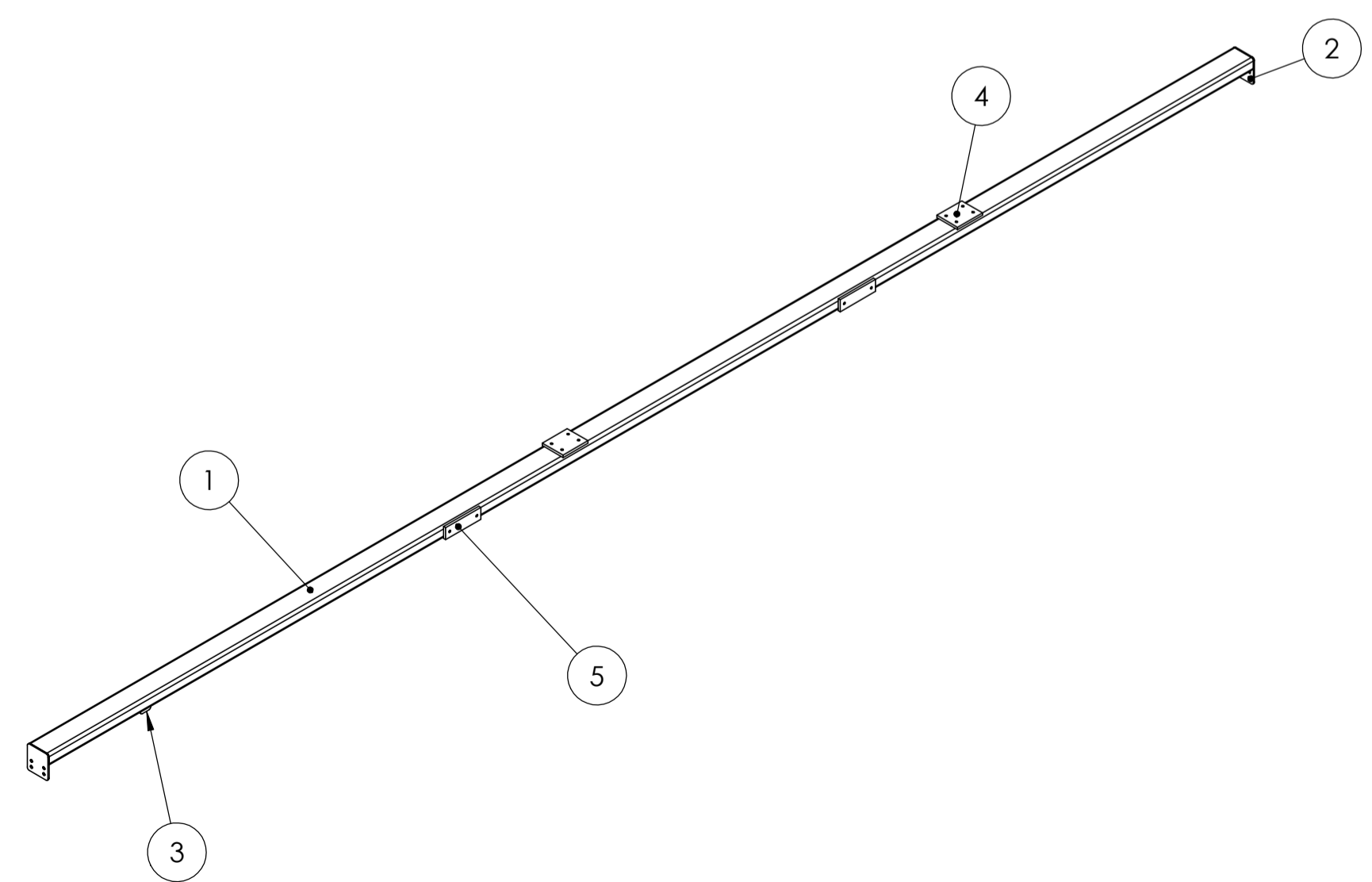
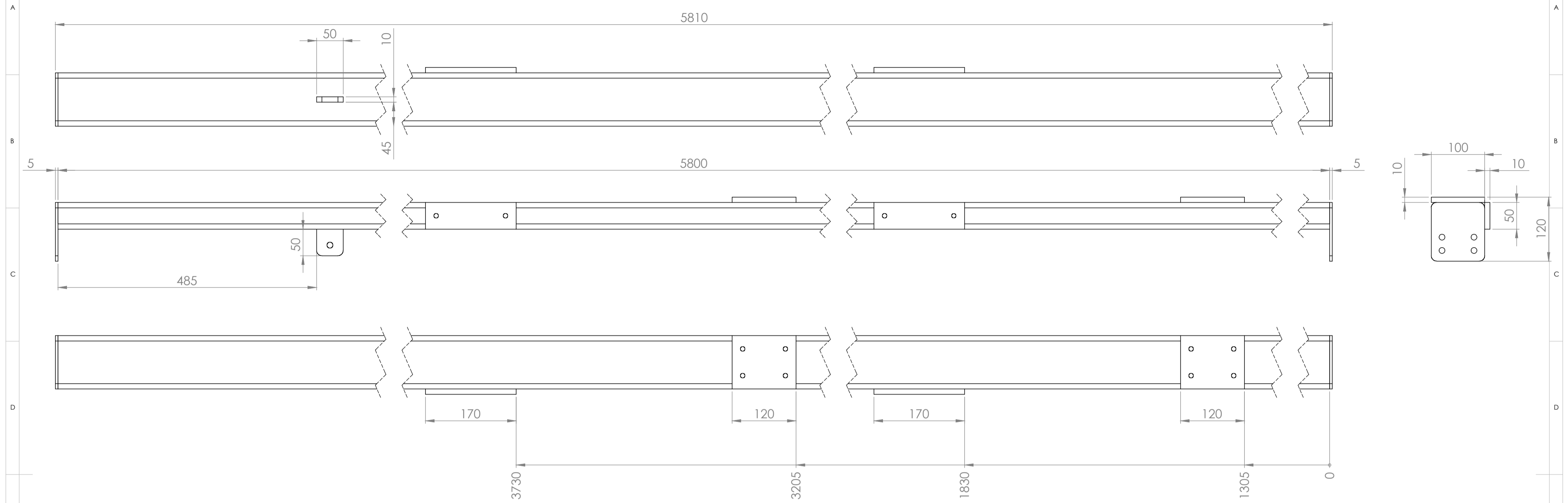

1 ks

PČ	NAZOV	ROZMER	MATERIAL	NORMA	POZNAMKA	KS
1	JOKEL 5	TR4HR 100x50x2 - 5800	hlinik			1
2	PLATNA 4	PL 10 - 110x100	hlinik			2
3	PRIRUBA 1	PL 10 - 50x50	hlinik			1
4	PLATNA 6	PL 10 - 120x100	hlinik			2
5	PLATNA 8	PL 10 - 170x50	hlinik			2

UNLESS OTHERWISE SPECIFIED: DIMENSIONS ARE IN MILLIMETERS
 SURFACE FINISH: TOLERANCES: LINEAR: ANGULAR:
 FINISH: DEBUR AND BREAK SHARP EDGES
 DO NOT SCALE DRAWING REVISION

DRAWN	NAME	SIGNATURE	DATE	TITLE:
CHK'D	cas10r		27.6.2012	PRIECKA 3b
APP'VD				DWG NO. SAV 15
MFG				A2
Q.A				SCALE:1:5 SHEET 15 OF 61

MATERIAL: hlinik

1 2 3 4 5 6 7 8

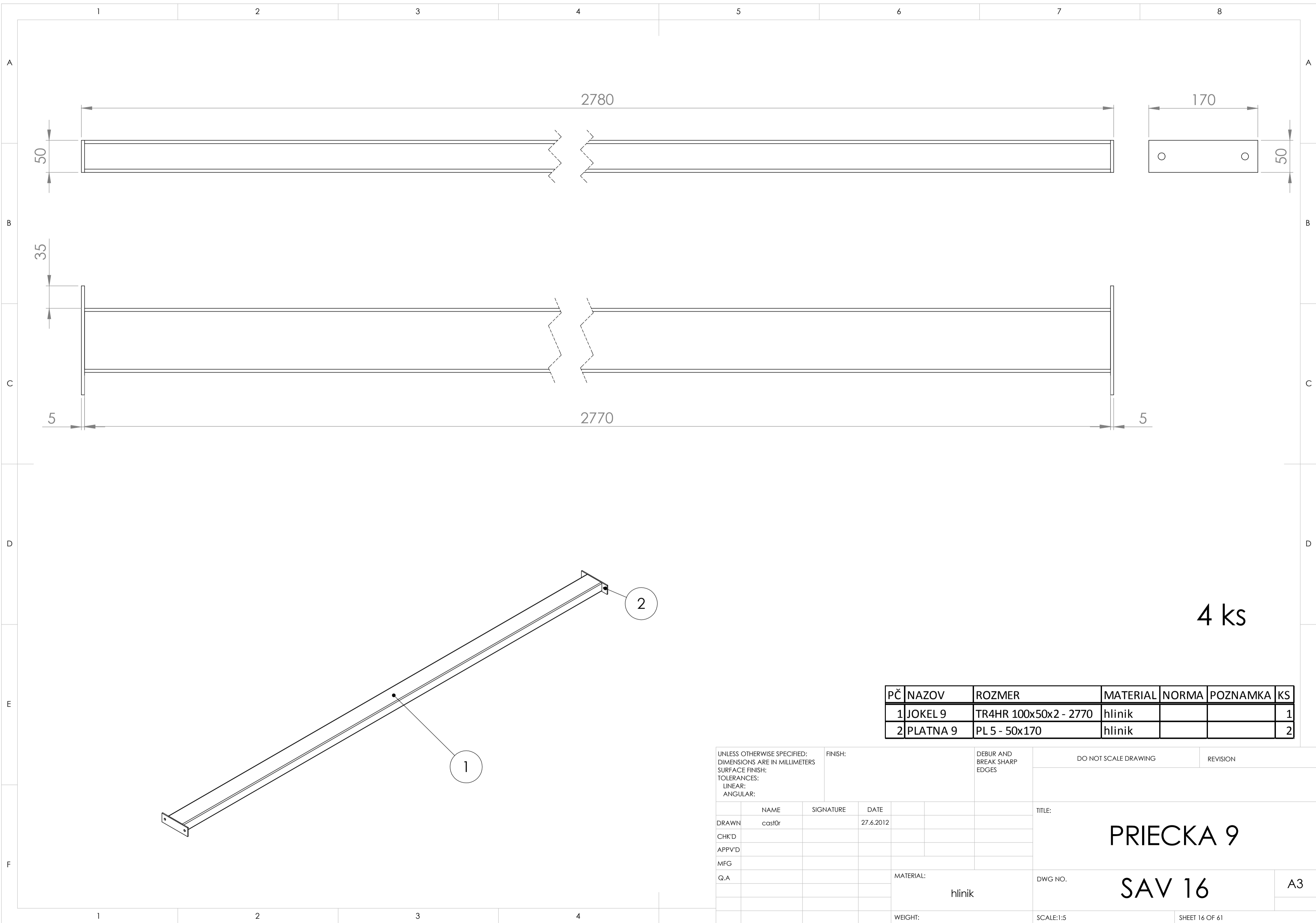

4 ks

PČ	NAZOV	ROZMER	MATERIAL	NORMA	POZNAMKA	KS
1	JOKEL 9	TR4HR 100x50x2 - 2770	hlinik			1
2	PLATNA 9	PL 5 - 50x170	hlinik			2

UNLESS OTHERWISE SPECIFIED: DIMENSIONS ARE IN MILLIMETERS SURFACE FINISH: TOLERANCES: LINEAR: ANGULAR:			FINISH:		DEBUR AND BREAK SHARP EDGES		DO NOT SCALE DRAWING		REVISION		
NAME	SIGNATURE	DATE					TITLE:				
DRAWN	cast0r	27.6.2012					PRIECKA 9				
CHK'D											
APPV'D											
MFG											
Q.A					MATERIAL: hlinik		DWG NO.		SAV 16		
					WEIGHT:		SCALE:1:5		SHEET 16 OF 61		
									A3		

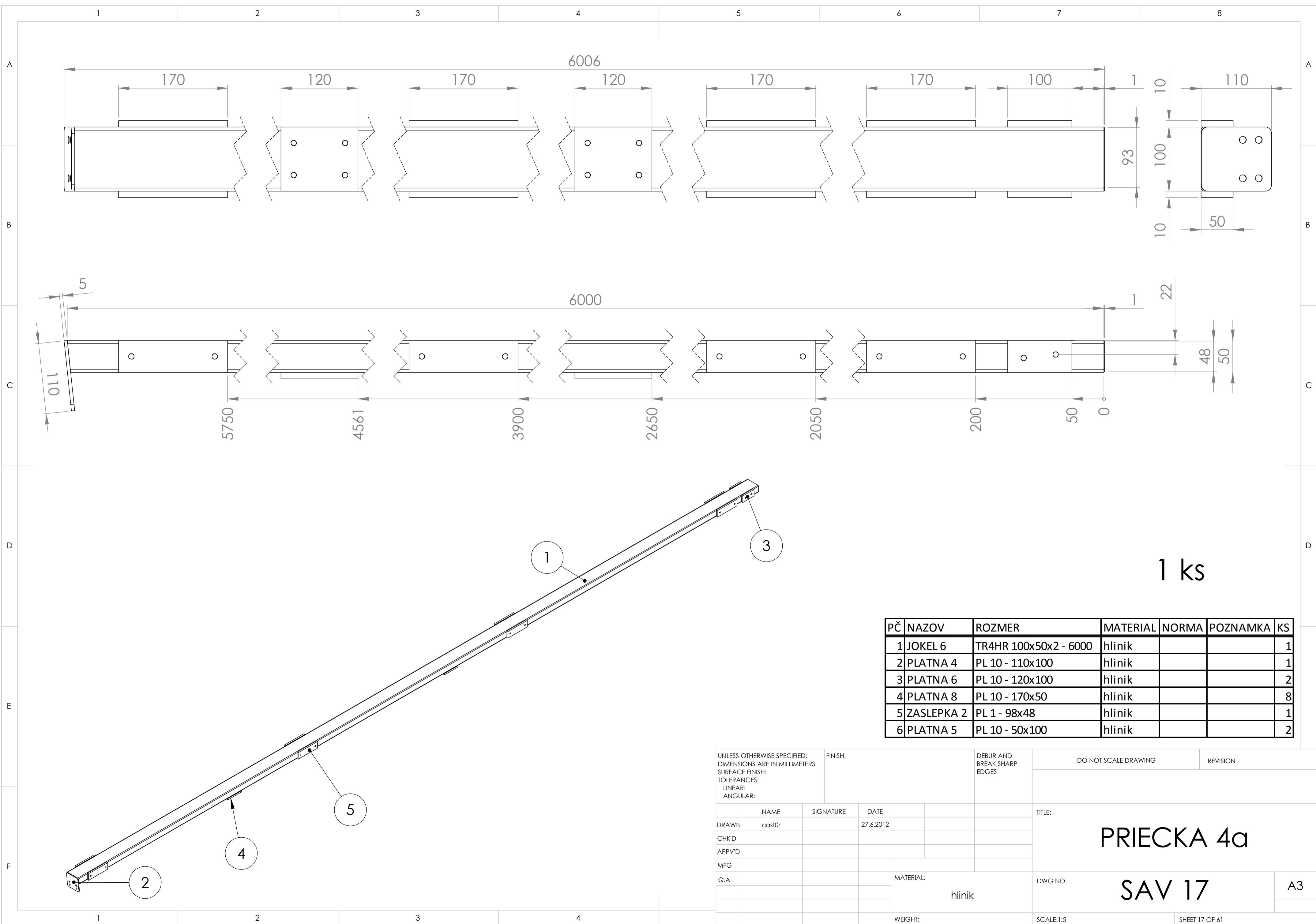

1 ks

PČ	NAZOV	ROZMER	MATERIAL	NORMA	POZNAMKA	KS
1	JOKEL 6	TR4HR 100x50x2 - 6000	hlinik			1
2	PLATNA 4	PL 10 - 110x100	hlinik			1
3	PLATNA 6	PL 10 - 120x100	hlinik			2
4	PLATNA 8	PL 10 - 170x50	hlinik			8
5	ZASLEPKA 2	PL 1 - 98x48	hlinik			1
6	PLATNA 5	PL 10 - 50x100	hlinik			2

UNLESS OTHERWISE SPECIFIED: DIMENSIONS ARE IN MILLIMETERS SURFACE FINISH: TOLERANCES: LINEAR: ANGULAR:			FINISH:		DEBUR AND BREAK SHARP EDGES		DO NOT SCALE DRAWING		REVISION	
NAME	SIGNATURE	DATE					TITLE:		PRIECKA 4a	
DRAWN	cast0r	27.6.2012					DWG NO.		SAV 17	
CHK'D							SCALE:1:5		SHEET 17 OF 61	
APPV'D							MATERIAL:		hlinik	
MFG							WEIGHT:			
Q.A							A3			

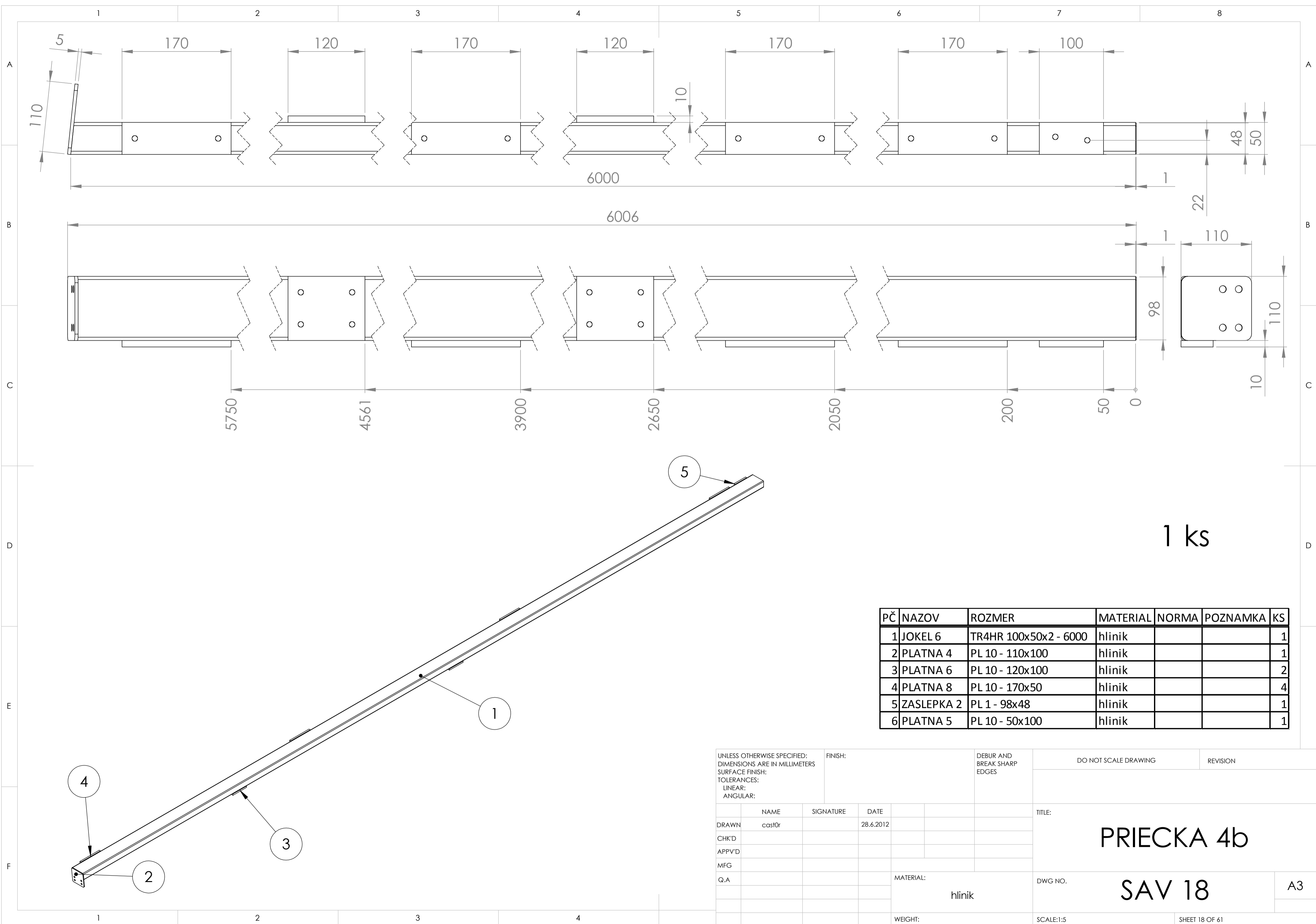

1 ks

PČ	NAZOV	ROZMER	MATERIAL	NORMA	POZNAMKA	KS
1	JOKEL 6	TR4HR 100x50x2 - 6000	hlinik			1
2	PLATNA 4	PL 10 - 110x100	hlinik			1
3	PLATNA 6	PL 10 - 120x100	hlinik			2
4	PLATNA 8	PL 10 - 170x50	hlinik			4
5	ZASLEPKA 2	PL 1 - 98x48	hlinik			1
6	PLATNA 5	PL 10 - 50x100	hlinik			1

UNLESS OTHERWISE SPECIFIED: DIMENSIONS ARE IN MILLIMETERS SURFACE FINISH: TOLERANCES: LINEAR: ANGULAR:			FINISH:		DEBUR AND BREAK SHARP EDGES		DO NOT SCALE DRAWING		REVISION	
NAME	SIGNATURE	DATE					TITLE:			
DRAWN	castOr	28.6.2012					PRIECKA 4b			
CHK'D							DWG NO.		A3	
APPV'D							SAV 18			
MFG					MATERIAL:		SCALE:1:5		SHEET 18 OF 61	
Q.A					hlinik					
					WEIGHT:					

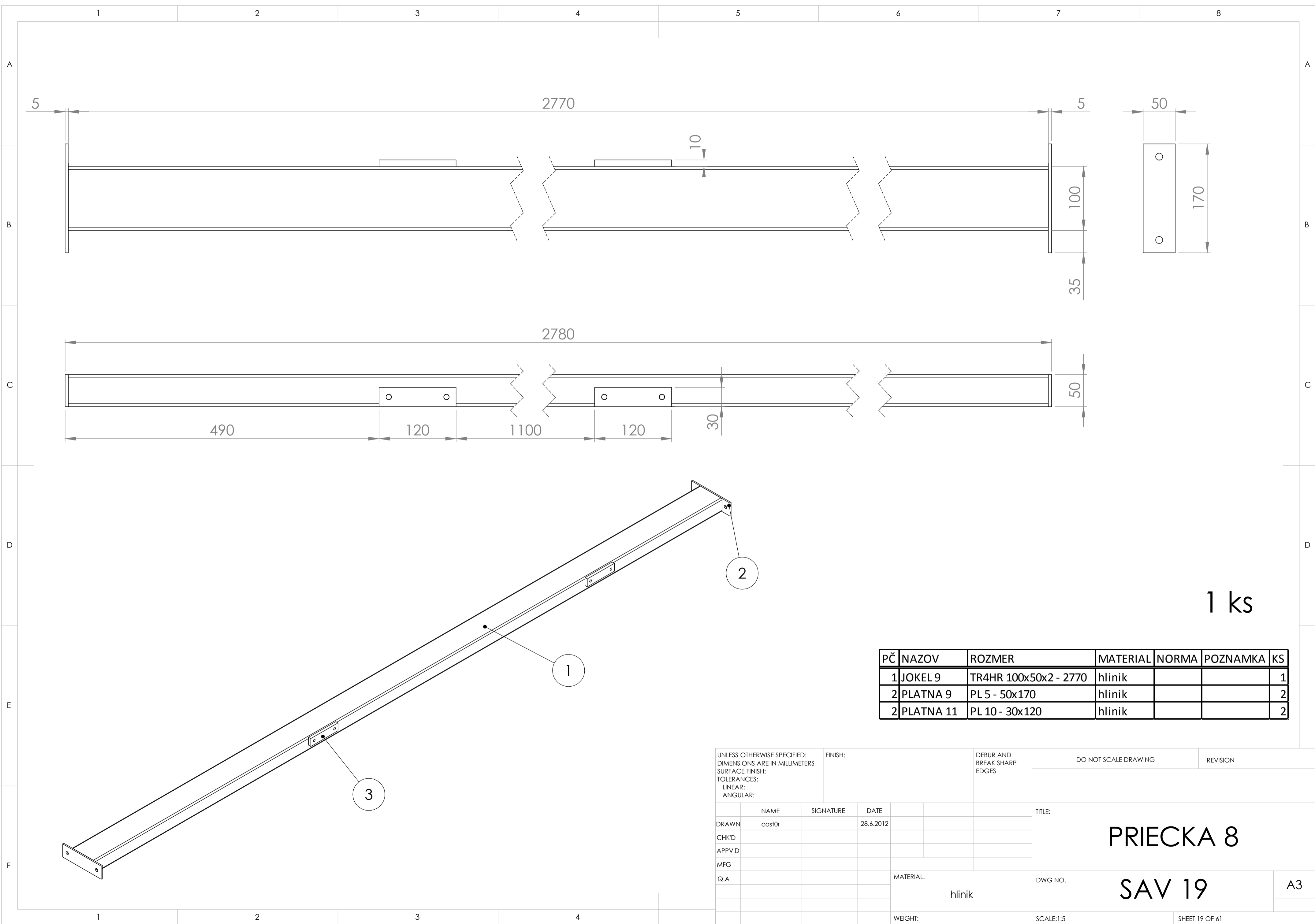

1 ks

PČ	NAZOV	ROZMER	MATERIAL	NORMA	POZNAMKA	KS
1	JOKEL 9	TR4HR 100x50x2 - 2770	hlinik			1
2	PLATNA 9	PL 5 - 50x170	hlinik			2
2	PLATNA 11	PL 10 - 30x120	hlinik			2

UNLESS OTHERWISE SPECIFIED: DIMENSIONS ARE IN MILLIMETERS SURFACE FINISH: TOLERANCES: LINEAR: ANGULAR:			FINISH:		DEBUR AND BREAK SHARP EDGES		DO NOT SCALE DRAWING		REVISION	
NAME	SIGNATURE	DATE					TITLE:			
DRAWN cast0r		28.6.2012					PRIECKA 8			
CHK'D							DWG NO.		A3	
APPV'D							SAV 19			
MFG					MATERIAL: hlinik		SCALE:1:5		SHEET 19 OF 61	
Q.A					WEIGHT:					

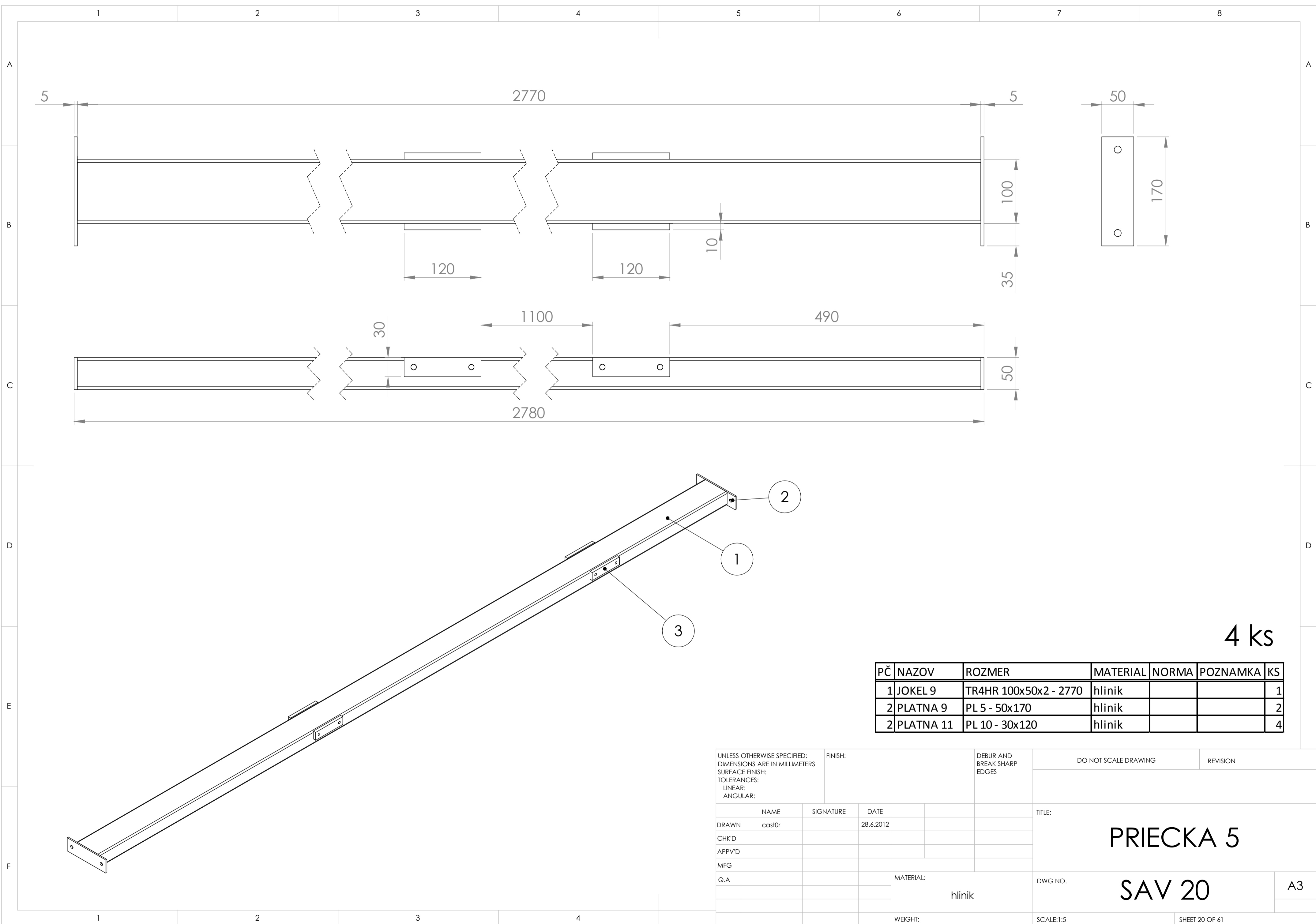

4 ks

PČ	NAZOV	ROZMER	MATERIAL	NORMA	POZNAMKA	KS
1	JOKEL 9	TR4HR 100x50x2 - 2770	hlinik			1
2	PLATNA 9	PL 5 - 50x170	hlinik			2
2	PLATNA 11	PL 10 - 30x120	hlinik			4

UNLESS OTHERWISE SPECIFIED: DIMENSIONS ARE IN MILLIMETERS SURFACE FINISH: TOLERANCES: LINEAR: ANGULAR:			FINISH:		DEBUR AND BREAK SHARP EDGES		DO NOT SCALE DRAWING		REVISION			
NAME	SIGNATURE	DATE				TITLE:		<p style="text-align: center; font-size: 24px;">PRIECKA 5</p> <p style="text-align: center; font-size: 36px;">SAV 20</p>				
DRAWN	cast0r	28.6.2012				DWG NO.					A3	
CHK'D						SCALE:1:5					SHEET 20 OF 61	
APPV'D						WEIGHT:						
MFG						MATERIAL:						
Q.A						hlinik						

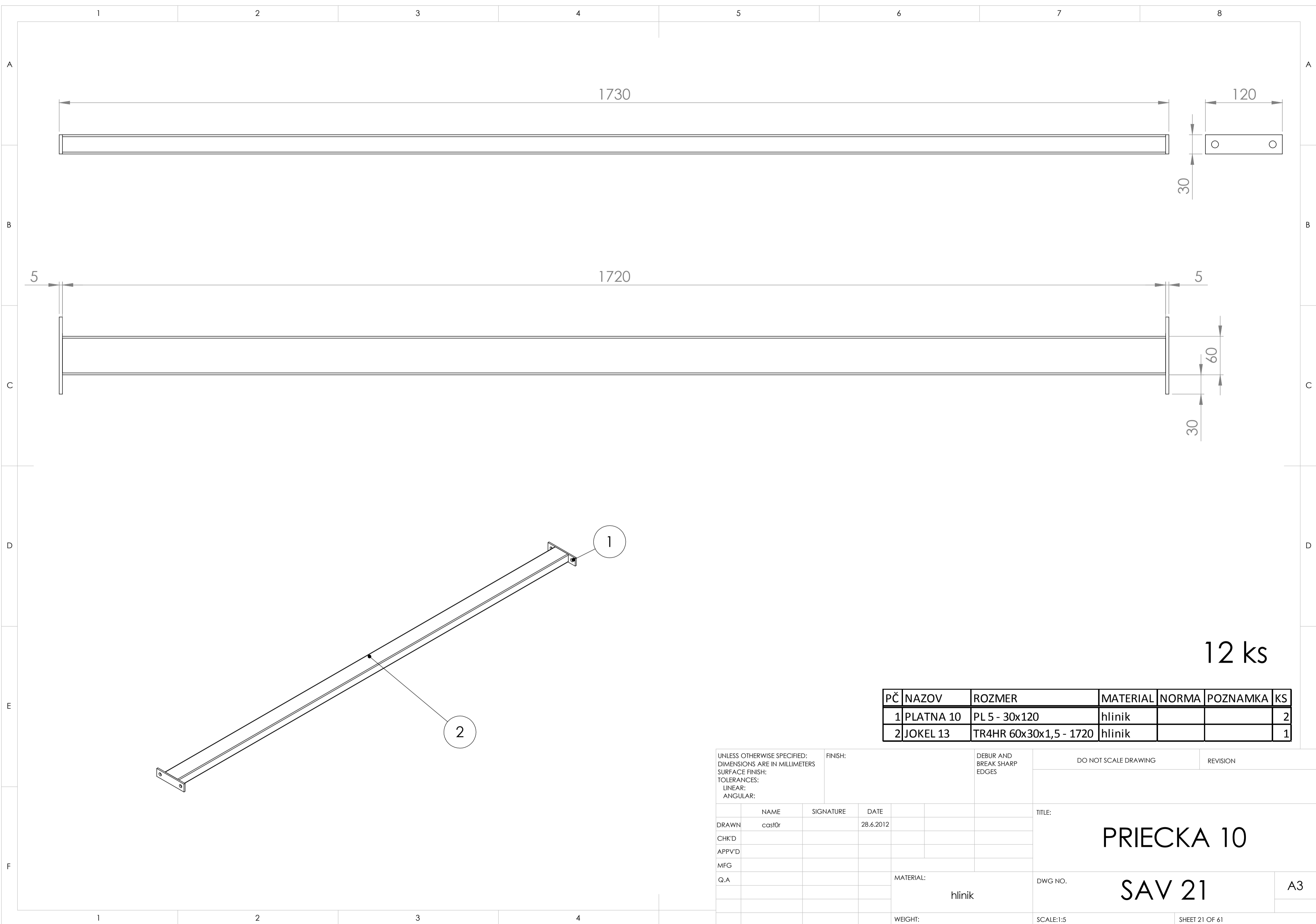

12 ks

PČ	NAZOV	ROZMER	MATERIAL	NORMA	POZNAMKA	KS
1	PLATNA 10	PL 5 - 30x120	hlinik			2
2	JOKEL 13	TR4HR 60x30x1,5 - 1720	hlinik			1

UNLESS OTHERWISE SPECIFIED: DIMENSIONS ARE IN MILLIMETERS SURFACE FINISH: TOLERANCES: LINEAR: ANGULAR:				FINISH:		DEBUR AND BREAK SHARP EDGES		DO NOT SCALE DRAWING		REVISION	
NAME	SIGNATURE	DATE				TITLE: PRIECKA 10					
DRAWN cast0r		28.6.2012				DWG NO. SAV 21					
CHK'D						SCALE:1:5					
APPV'D						SHEET 21 OF 61					
MFG						A3					
Q.A					MATERIAL: hlinik						
					WEIGHT:						

1 2 3 4 5 6 7 8

A
B
C
D
E
F

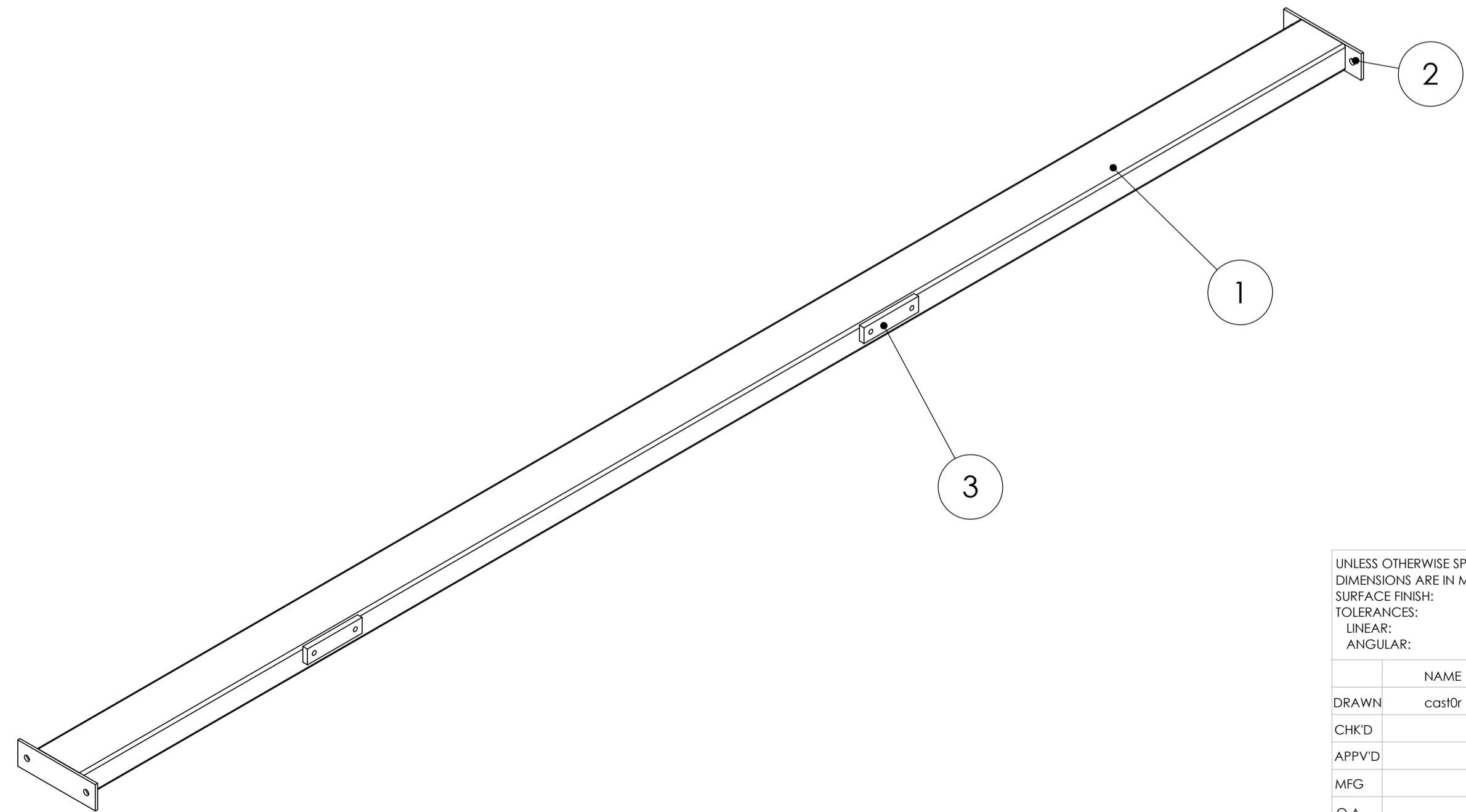
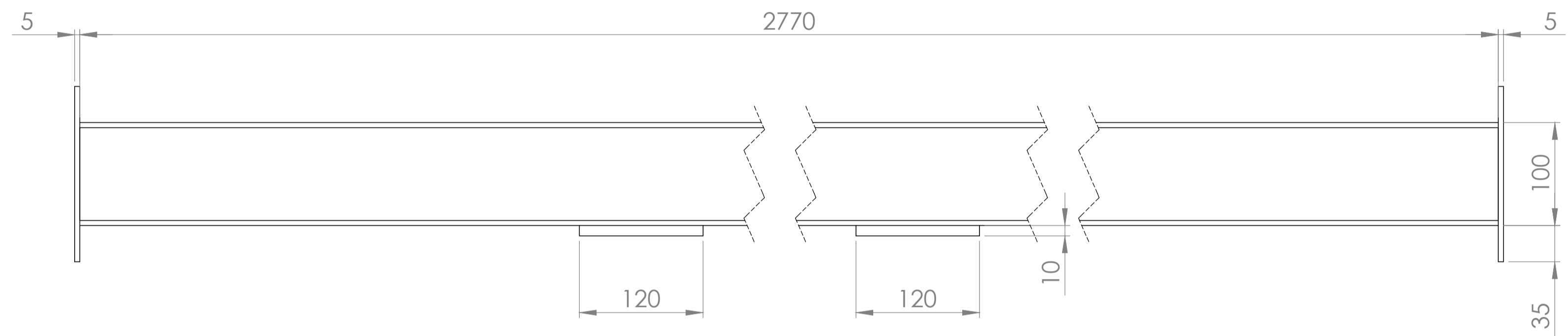
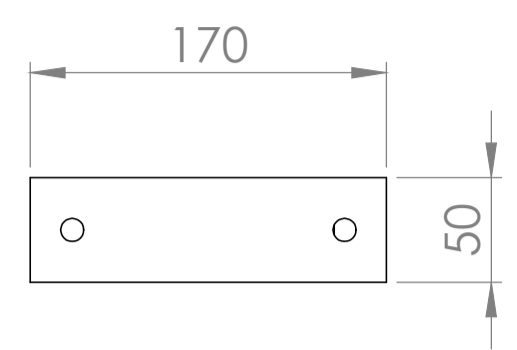
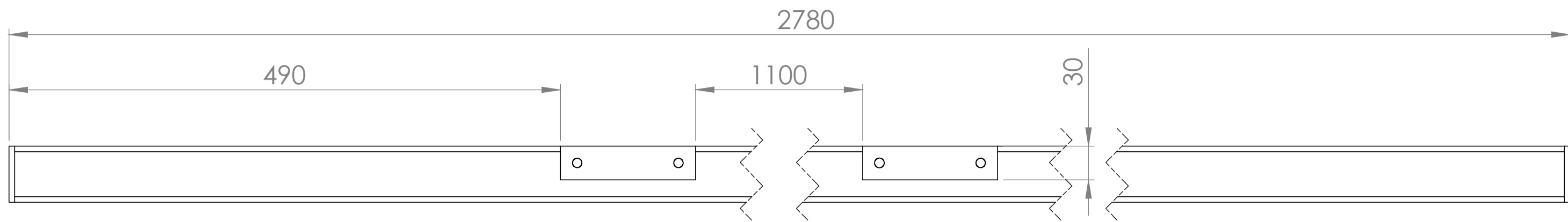

1 ks

PČ	NAZOV	ROZMER	MATERIAL	NORMA	POZNAMKA	KS
1	JOKEL 9	TR4HR 100x50x2 - 2770	hlinik			1
2	PLATNA 9	PL 5 - 50x170	hlinik			2
3	PLATNA 11	PL 10 - 30x120	hlinik			2

UNLESS OTHERWISE SPECIFIED: DIMENSIONS ARE IN MILLIMETERS SURFACE FINISH: TOLERANCES: LINEAR: ANGULAR:			FINISH:		DEBUR AND BREAK SHARP EDGES		DO NOT SCALE DRAWING		REVISION		
NAME	SIGNATURE	DATE				TITLE:					
DRAWN cast0r		28.6.2012				<h1>PRIECKA 8a</h1> <h2>SAV 22</h2>					
CHK'D											
APPV'D											
MFG											
Q.A			MATERIAL: hlinik			DWG NO.		SCALE:1:5		SHEET 22 OF 61	
			WEIGHT:							A3	

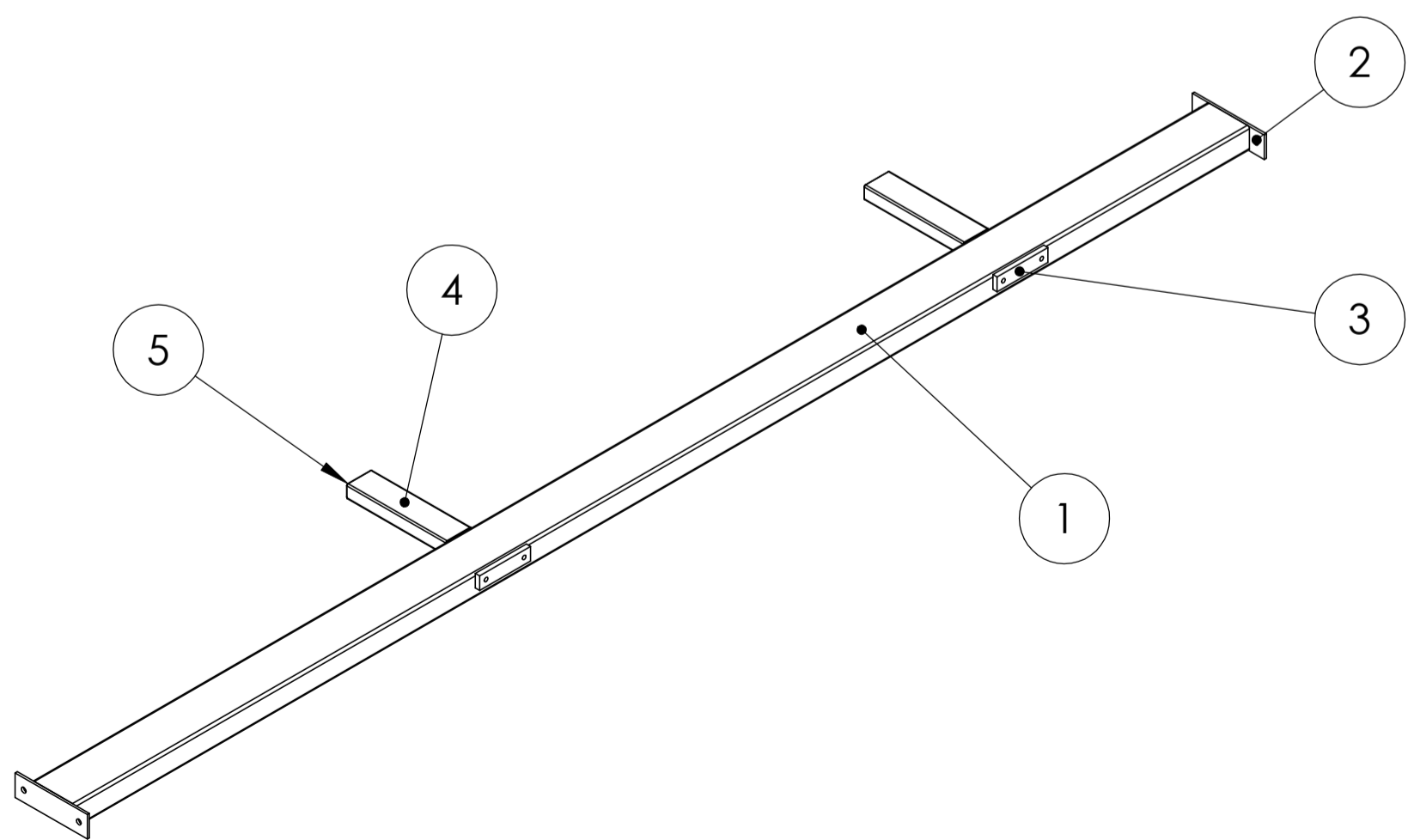
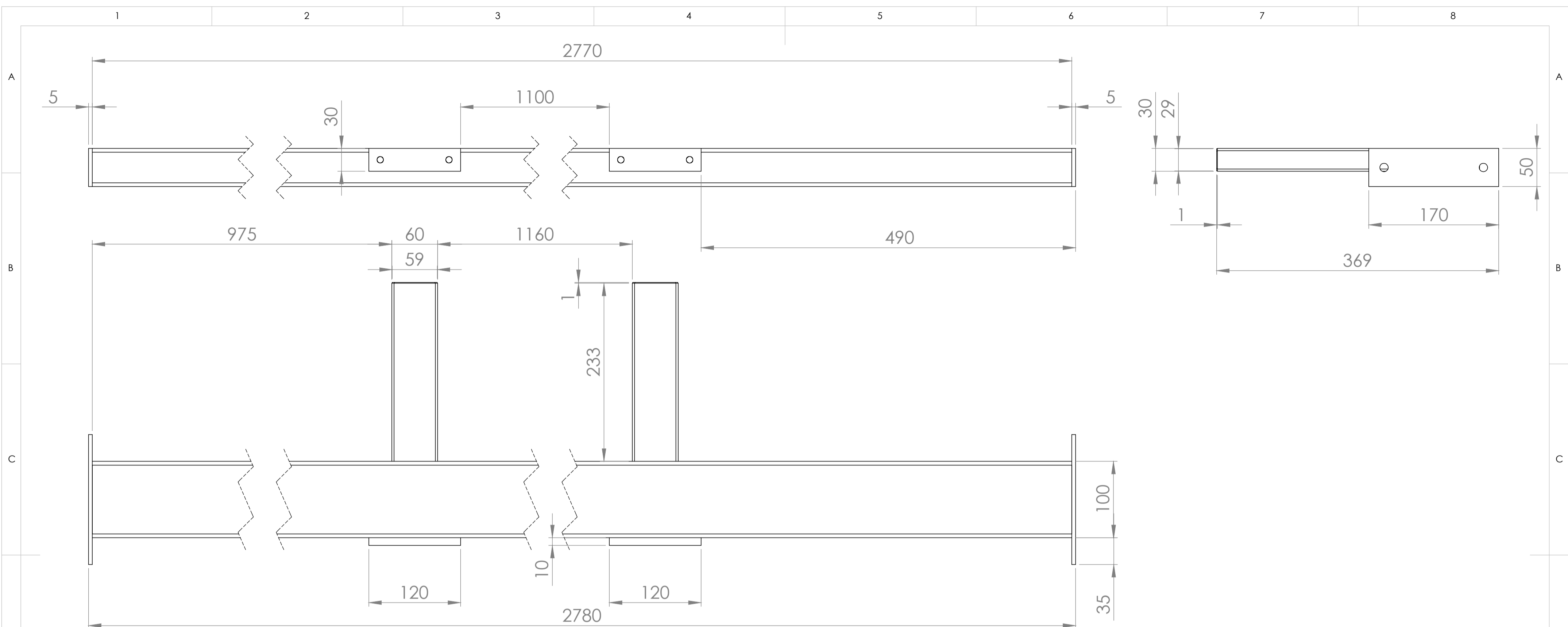

1 ks

PČ	NAZOV	ROZMER	MATERIAL	NORMA	POZNAMKA	KS
1	JOKEL 9	TR4HR 100x50x2 - 2770	hlinik			1
2	PLATNA 9	PL 5 - 50x170	hlinik			2
3	PLATNA 11	PL 10 - 30x120	hlinik			2
4	JOKEL15	TR4HR 60x30x1,5 - 233	hlinik			2
5	ZASLEPKA 1	PL 1 - 59x29	hlinik			2

UNLESS OTHERWISE SPECIFIED: DIMENSIONS ARE IN MILLIMETERS SURFACE FINISH: TOLERANCES: LINEAR: ANGULAR:			FINISH:	DEBUR AND BREAK SHARP EDGES	DO NOT SCALE DRAWING	REVISION
NAME	SIGNATURE	DATE	TITLE:			
DRAWN castOr		28.6.2012	PRIECKA 8pp			
CHK'D						
APPV'D						
MFG						
Q.A			MATERIAL: hlinik	DWG NO.	SAV 23	A3
			WEIGHT:	SCALE:1:5	SHEET 23 OF 61	

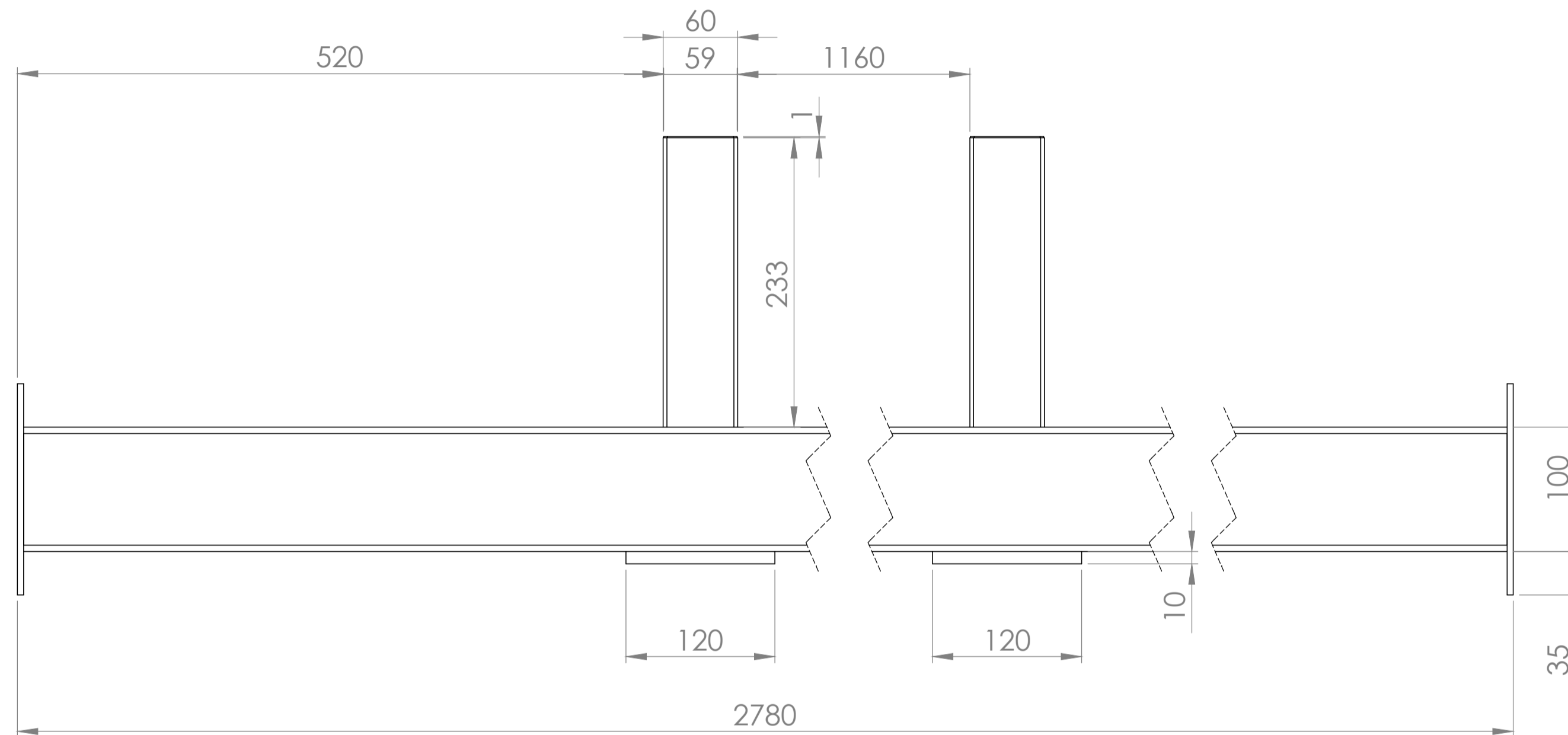
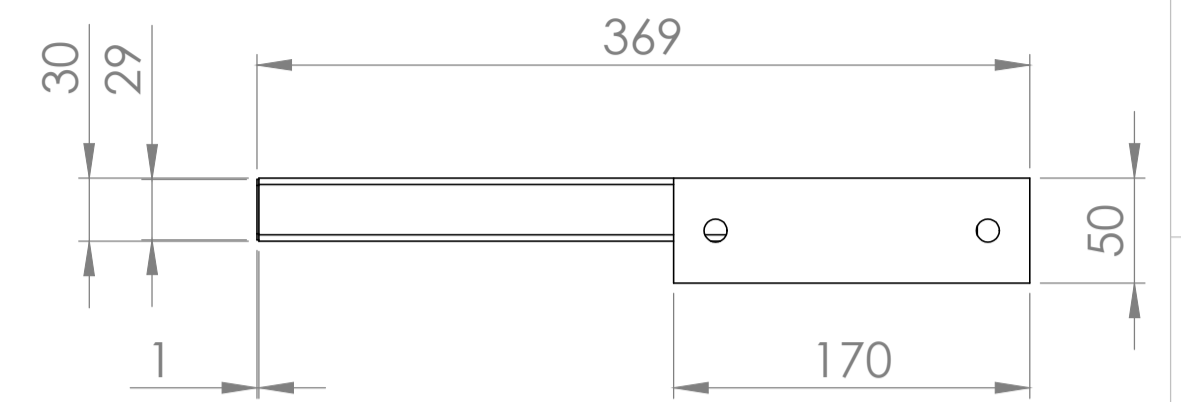
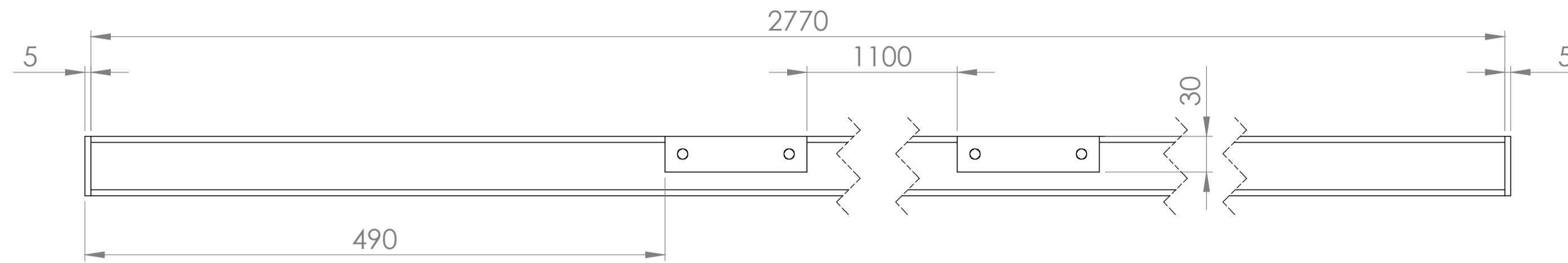

1 ks

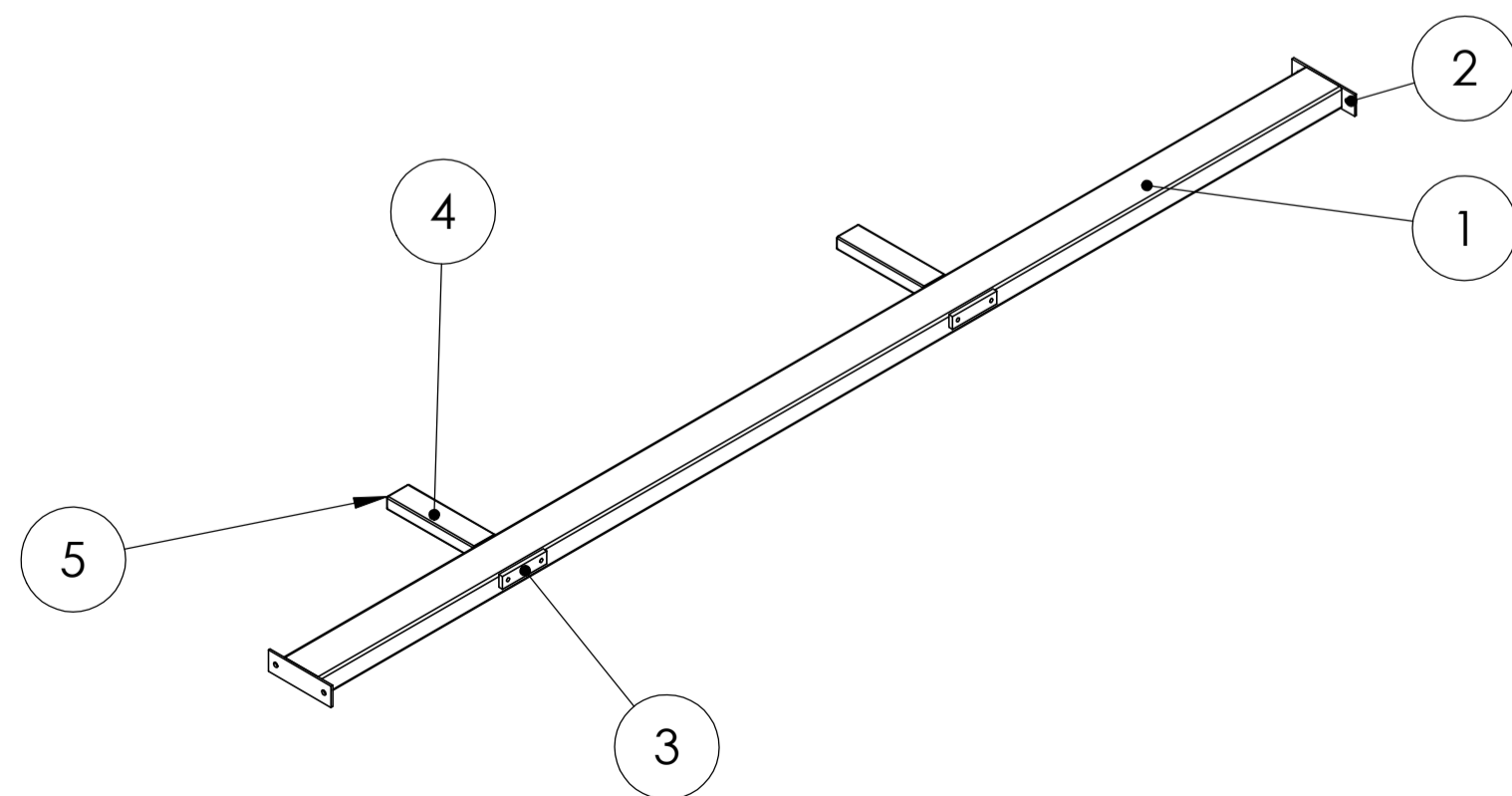

PČ	NAZOV	ROZMER	MATERIAL	NORMA	POZNAMKA	KS
1	JOKEĽ 9	TR4HR 100x50x2 - 2770	hlinik			1
2	PLATNA 9	PL 5 - 50x170	hlinik			2
3	PLATNA 11	PL 10 - 30x120	hlinik			2
4	JOKEĽ15	TR4HR 60x30x1,5 - 233	hlinik			2
5	ZASLEPKA 1	PL 1 - 59x29	hlinik			2

UNLESS OTHERWISE SPECIFIED:
DIMENSIONS ARE IN MILLIMETERS
SURFACE FINISH:
TOLERANCES:
LINEAR:
ANGULAR:

FINISH:

DEBUR AND
BREAK SHARP
EDGES

DO NOT SCALE DRAWING

REVISION

	NAME	SIGNATURE	DATE
DRAWN	cast0r		28.6.2012
CHK'D			
APPV'D			
MFG			
Q.A			

TITLE:

PRIECKA 8ap

DWG NO.

SAV 24

A3

WEIGHT:

SCALE:1:5

SHEET 24 OF 61

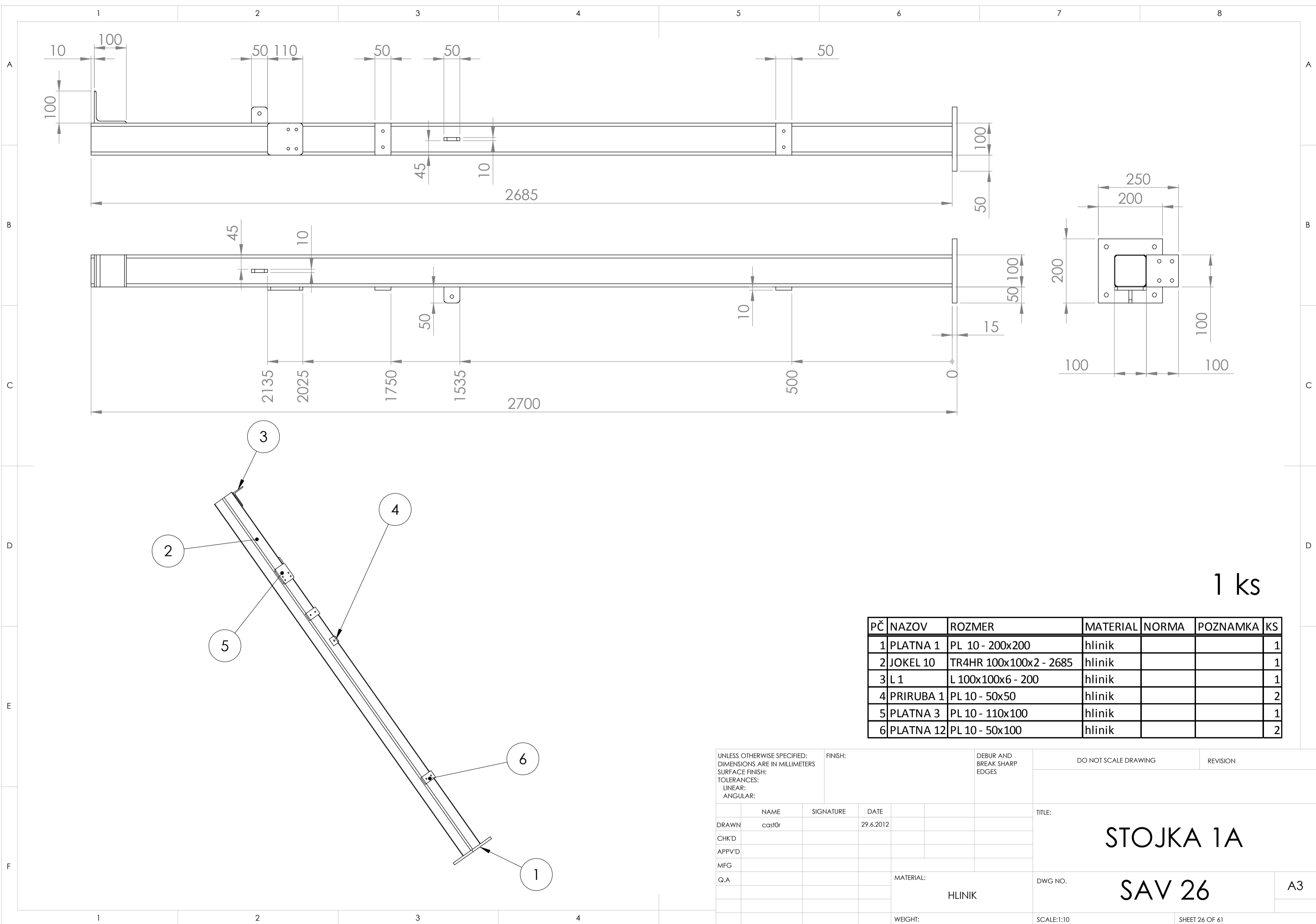

1 ks

PČ	NAZOV	ROZMER	MATERIAL	NORMA	POZNAMKA	KS
1	PLATNA 1	PL 10 - 200x200	hlinik			1
2	JOKEL 10	TR4HR 100x100x2 - 2685	hlinik			1
3	L 1	L 100x100x6 - 200	hlinik			1
4	PRIRUBA 1	PL 10 - 50x50	hlinik			2
5	PLATNA 3	PL 10 - 110x100	hlinik			1
6	PLATNA 12	PL 10 - 50x100	hlinik			2

UNLESS OTHERWISE SPECIFIED: DIMENSIONS ARE IN MILLIMETERS SURFACE FINISH: TOLERANCES: LINEAR: ANGULAR:			FINISH:		DEBUR AND BREAK SHARP EDGES		DO NOT SCALE DRAWING		REVISION	
NAME	SIGNATURE	DATE					TITLE:		<h1>STOJKA 1A</h1> <h2>SAV 26</h2>	
DRAWN	castOr	29.6.2012					DWG NO.			
CHK'D							SCALE:1:10			
APPV'D							SHEET 26 OF 61			
MFG										
Q.A			MATERIAL:		HLINIK				A3	
			WEIGHT:							

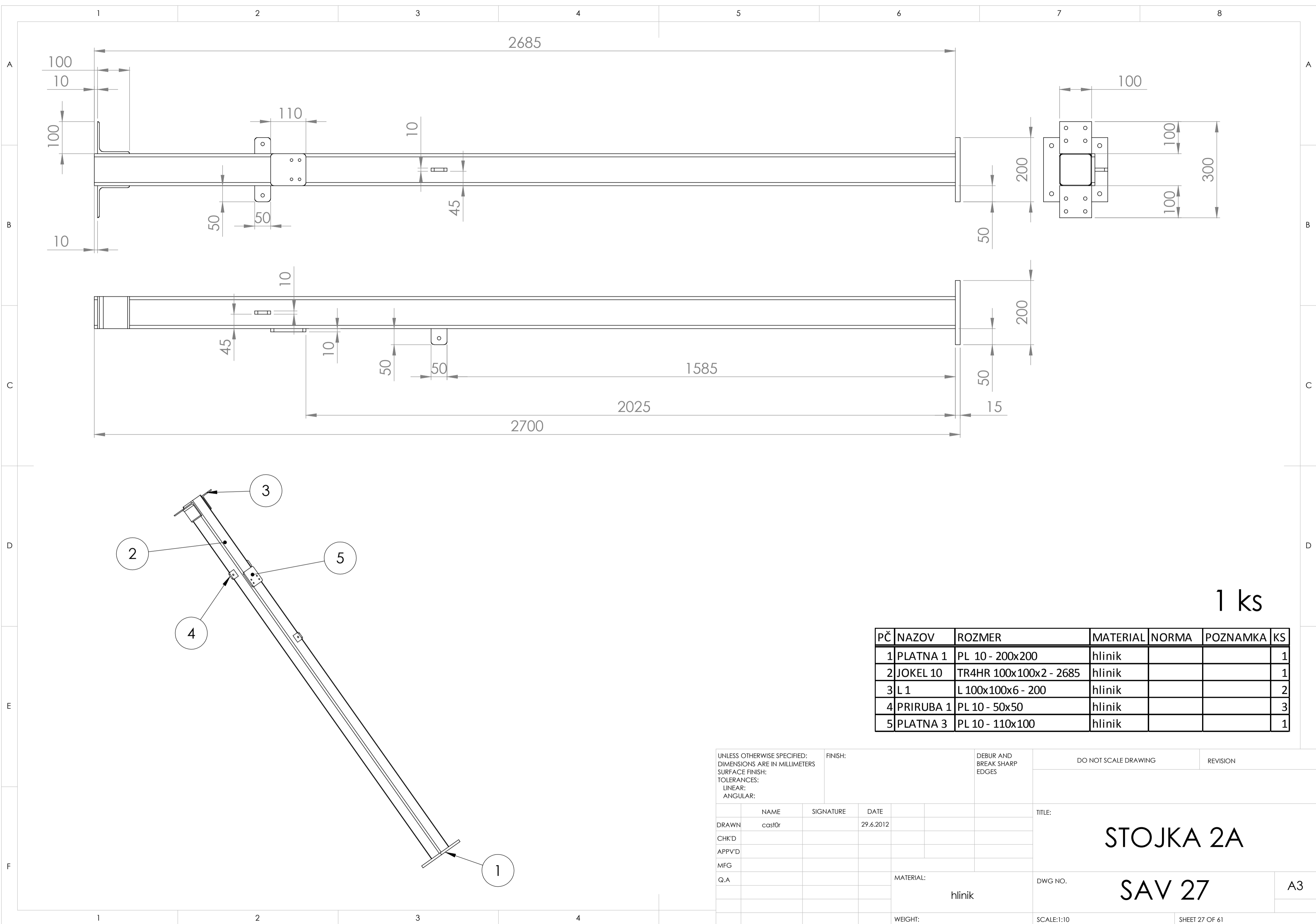

1 ks

PČ	NAZOV	ROZMER	MATERIAL	NORMA	POZNAMKA	KS
1	PLATNA 1	PL 10 - 200x200	hlinik			1
2	JOKEL 10	TR4HR 100x100x2 - 2685	hlinik			1
3	L 1	L 100x100x6 - 200	hlinik			2
4	PRIRUBA 1	PL 10 - 50x50	hlinik			3
5	PLATNA 3	PL 10 - 110x100	hlinik			1

UNLESS OTHERWISE SPECIFIED: DIMENSIONS ARE IN MILLIMETERS SURFACE FINISH: TOLERANCES: LINEAR: ANGULAR:			FINISH:		DEBUR AND BREAK SHARP EDGES		DO NOT SCALE DRAWING		REVISION		
NAME	SIGNATURE	DATE					TITLE:				
DRAWN cast0r		29.6.2012					<p style="text-align: center; font-size: 24px; font-weight: bold;">STOJKA 2A</p> <p style="text-align: center; font-size: 36px; font-weight: bold;">SAV 27</p>				
CHK'D											
APPV'D											
MFG											
Q.A			MATERIAL:		hlinik		DWG NO.		A3		
			WEIGHT:				SCALE:1:10		SHEET 27 OF 61		

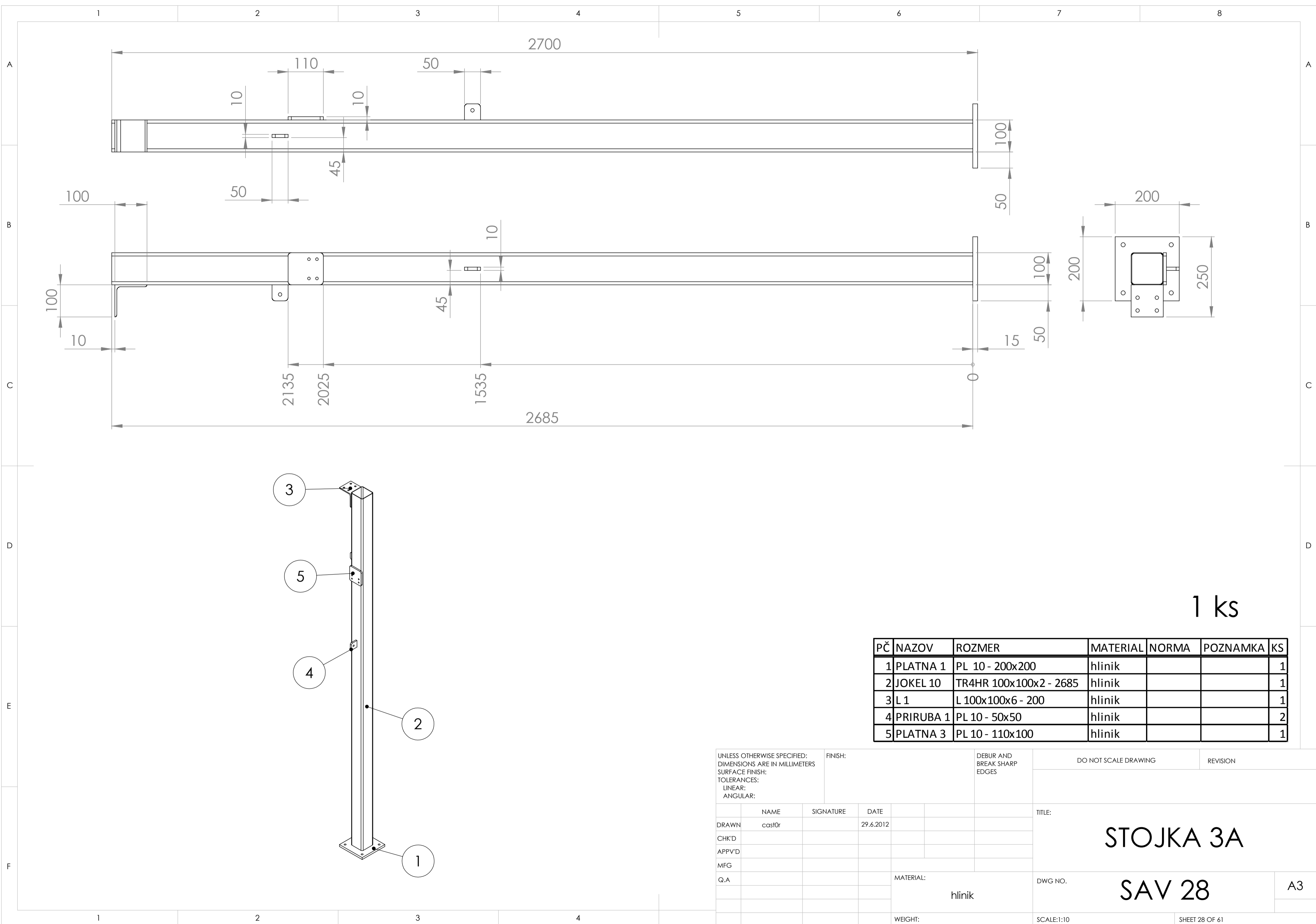

1 ks

PČ	NAZOV	ROZMER	MATERIAL	NORMA	POZNAMKA	KS
1	PLATNA 1	PL 10 - 200x200	hlinik			1
2	JOKEL 10	TR4HR 100x100x2 - 2685	hlinik			1
3	L 1	L 100x100x6 - 200	hlinik			1
4	PRIRUBA 1	PL 10 - 50x50	hlinik			2
5	PLATNA 3	PL 10 - 110x100	hlinik			1

UNLESS OTHERWISE SPECIFIED: DIMENSIONS ARE IN MILLIMETERS SURFACE FINISH: TOLERANCES: LINEAR: ANGULAR:			FINISH:		DEBUR AND BREAK SHARP EDGES		DO NOT SCALE DRAWING		REVISION		
NAME	SIGNATURE	DATE					TITLE:				
DRAWN	cast0r	29.6.2012					<h1>STOJKA 3A</h1>				
CHK'D											
APPV'D											
MFG											
Q.A			MATERIAL:		hlinik		DWG NO.		SAV 28		
			WEIGHT:				SCALE:1:10		SHEET 28 OF 61		

A3

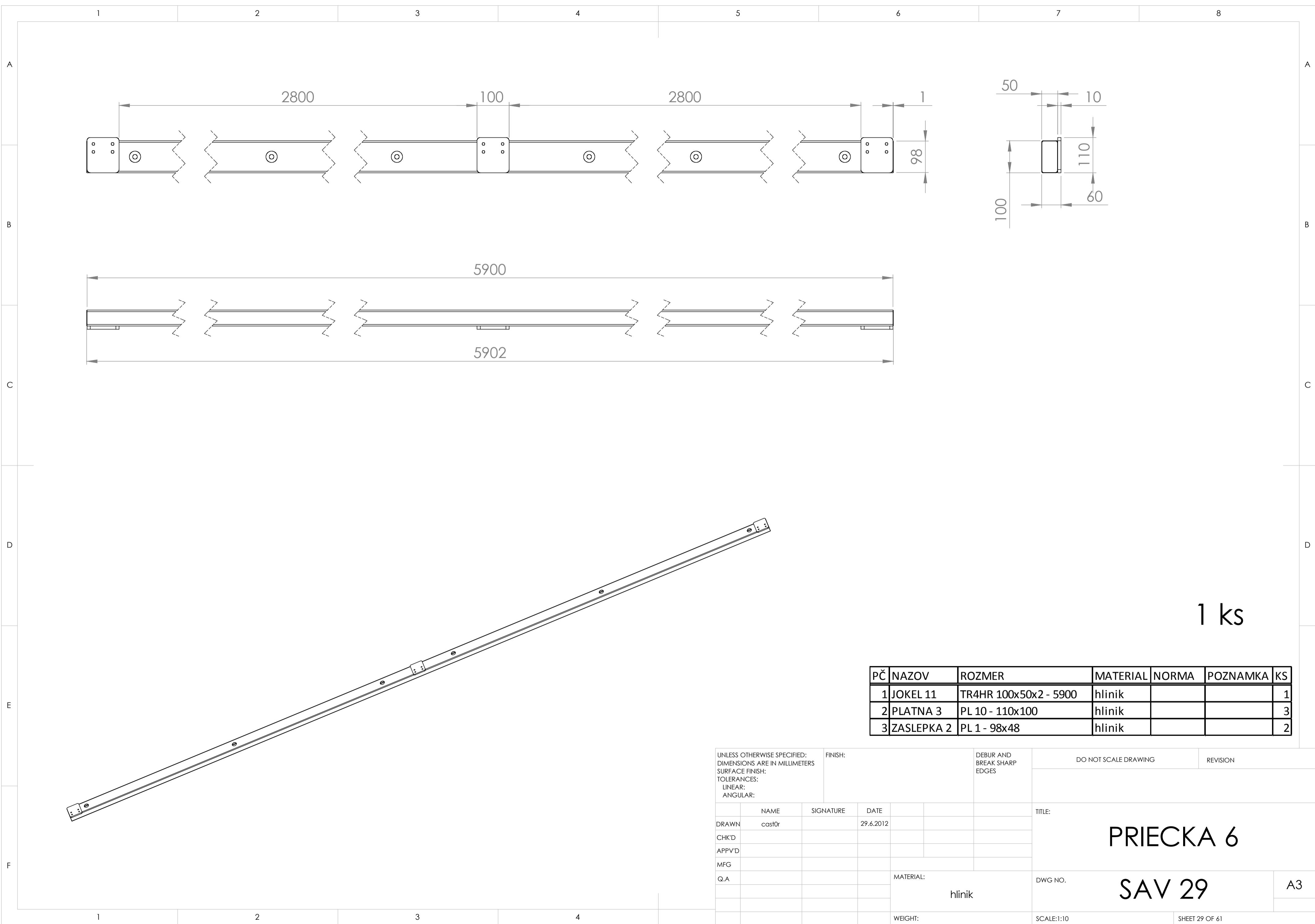

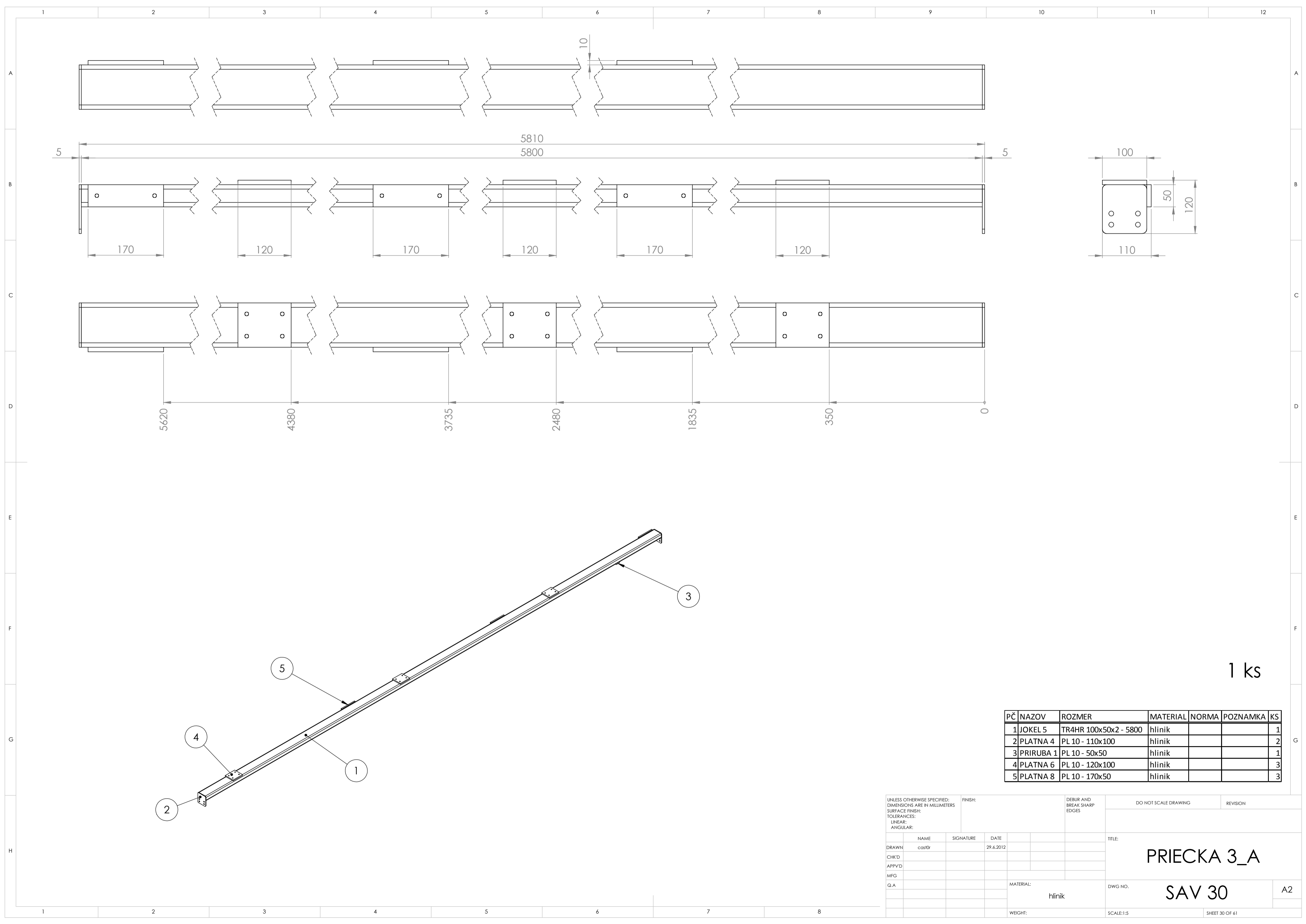

1 ks

PČ	NAZOV	ROZMER	MATERIAL	NORMA	POZNAMKA	KS
1	JOKEL 5	TR4HR 100x50x2 - 5800	hlinik			1
2	PLATNA 4	PL 10 - 110x100	hlinik			2
3	PRIRUBA 1	PL 10 - 50x50	hlinik			1
4	PLATNA 6	PL 10 - 120x100	hlinik			3
5	PLATNA 8	PL 10 - 170x50	hlinik			3

UNLESS OTHERWISE SPECIFIED: DIMENSIONS ARE IN MILLIMETERS			FINISH:		DEBUR AND BREAK SHARP EDGES		DO NOT SCALE DRAWING		REVISION	
SURFACE FINISH:										
TOLERANCES:										
LINEAR:										
ANGULAR:										
DRAWN	NAME	SIGNATURE	DATE					TITLE:		
CHKD	cas10r		29.6.2012					PRIECKA 3_A		
APPVD								DWG NO.		
MFG						MATERIAL:		SAV 30		A2
Q.A						hlinik		SCALE:1:5		
					WEIGHT:		SHEET 30 OF 61			

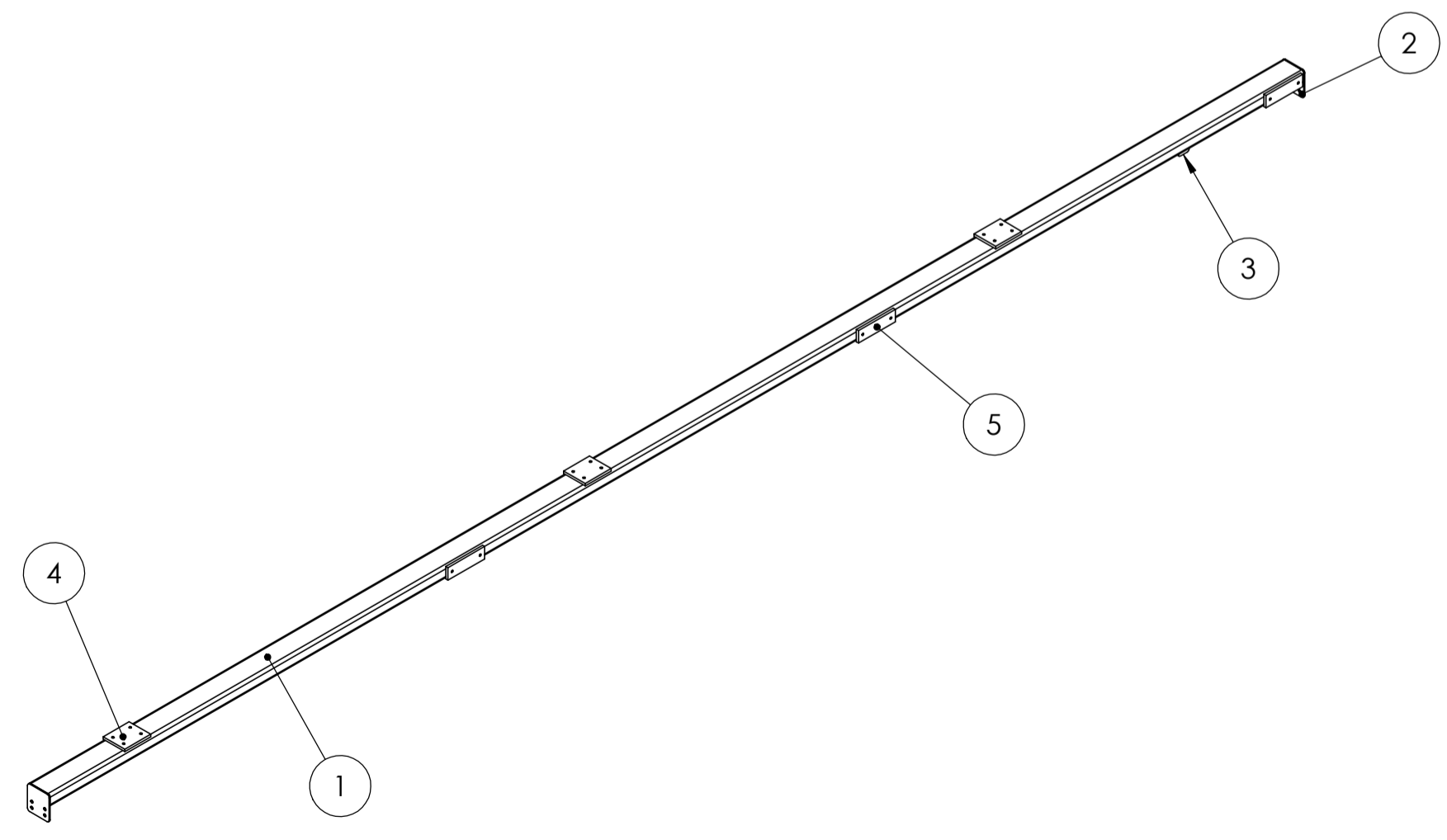
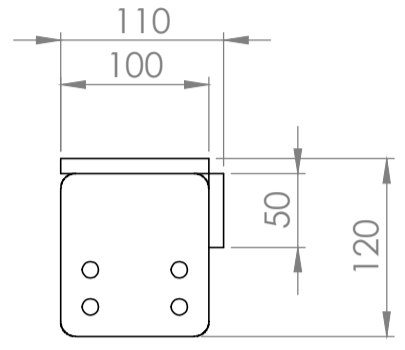
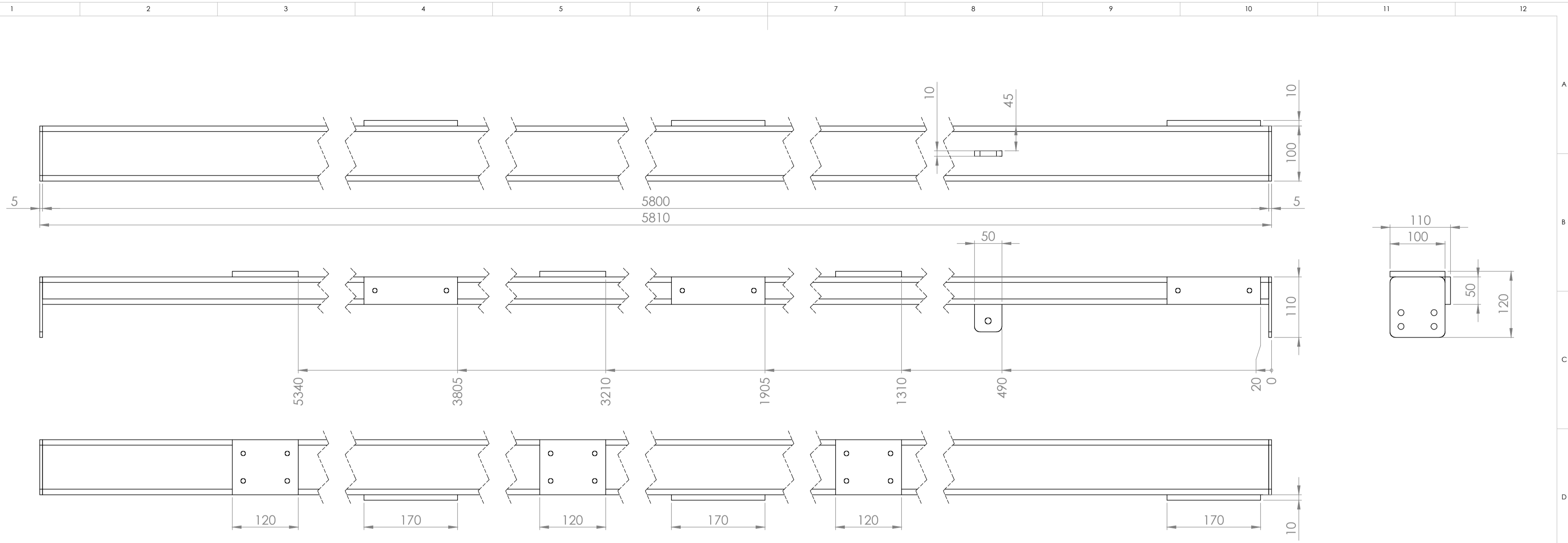

1 ks

PČ	NAZOV	ROZMER	MATERIAL	NORMA	POZNAMKA	KS
1	JOKEL 5	TR4HR 100x50x2 - 5800	hlinik			1
2	PLATNA 4	PL 10 - 110x100	hlinik			2
3	PRIRUBA 1	PL 10 - 50x50	hlinik			1
4	PLATNA 6	PL 10 - 120x100	hlinik			3
5	PLATNA 8	PL 10 - 170x50	hlinik			3

UNLESS OTHERWISE SPECIFIED: DIMENSIONS ARE IN MILLIMETERS			FINISH:		DEBUR AND BREAK SHARP EDGES		DO NOT SCALE DRAWING		REVISION	
SURFACE FINISH:										
TOLERANCES:										
LINEAR:										
ANGULAR:										
DRAWN	NAME	SIGNATURE	DATE					TITLE:		
CHK'D	cas10r		29.6.2012					PRIECKA 3b_A		
APP'VD								DWG NO.		
MFG								SAV 32		A2
Q.A						MATERIAL:				
						hlinik				
						WEIGHT:				
								SCALE:1:5		SHEET 32 OF 61

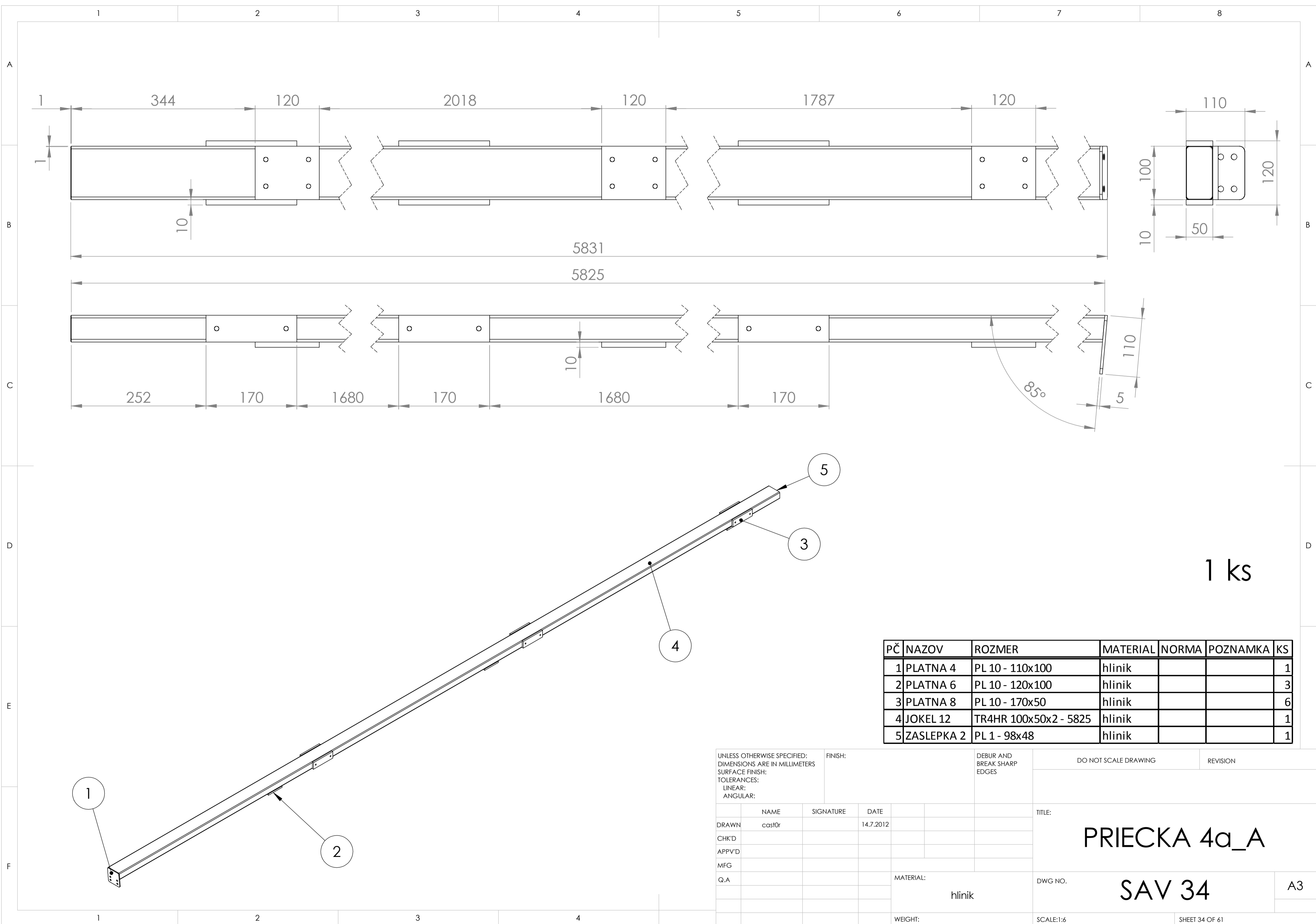

1 ks

PČ	NAZOV	ROZMER	MATERIAL	NORMA	POZNAMKA	KS
1	PLATNA 4	PL 10 - 110x100	hlinik			1
2	PLATNA 6	PL 10 - 120x100	hlinik			3
3	PLATNA 8	PL 10 - 170x50	hlinik			6
4	JOKEL 12	TR4HR 100x50x2 - 5825	hlinik			1
5	ZASLEPKA 2	PL 1 - 98x48	hlinik			1

UNLESS OTHERWISE SPECIFIED: DIMENSIONS ARE IN MILLIMETERS SURFACE FINISH: TOLERANCES: LINEAR: ANGULAR:			FINISH:		DEBUR AND BREAK SHARP EDGES		DO NOT SCALE DRAWING		REVISION	
NAME	SIGNATURE	DATE				TITLE:				
DRAWN	castOr	14.7.2012				PRIECKA 4a_A				
CHK'D						DWG NO.				
APPV'D						SAV 34				
MFG						SCALE:1:6				
Q.A			MATERIAL: hlinik			SHEET 34 OF 61				
			WEIGHT:			A3				

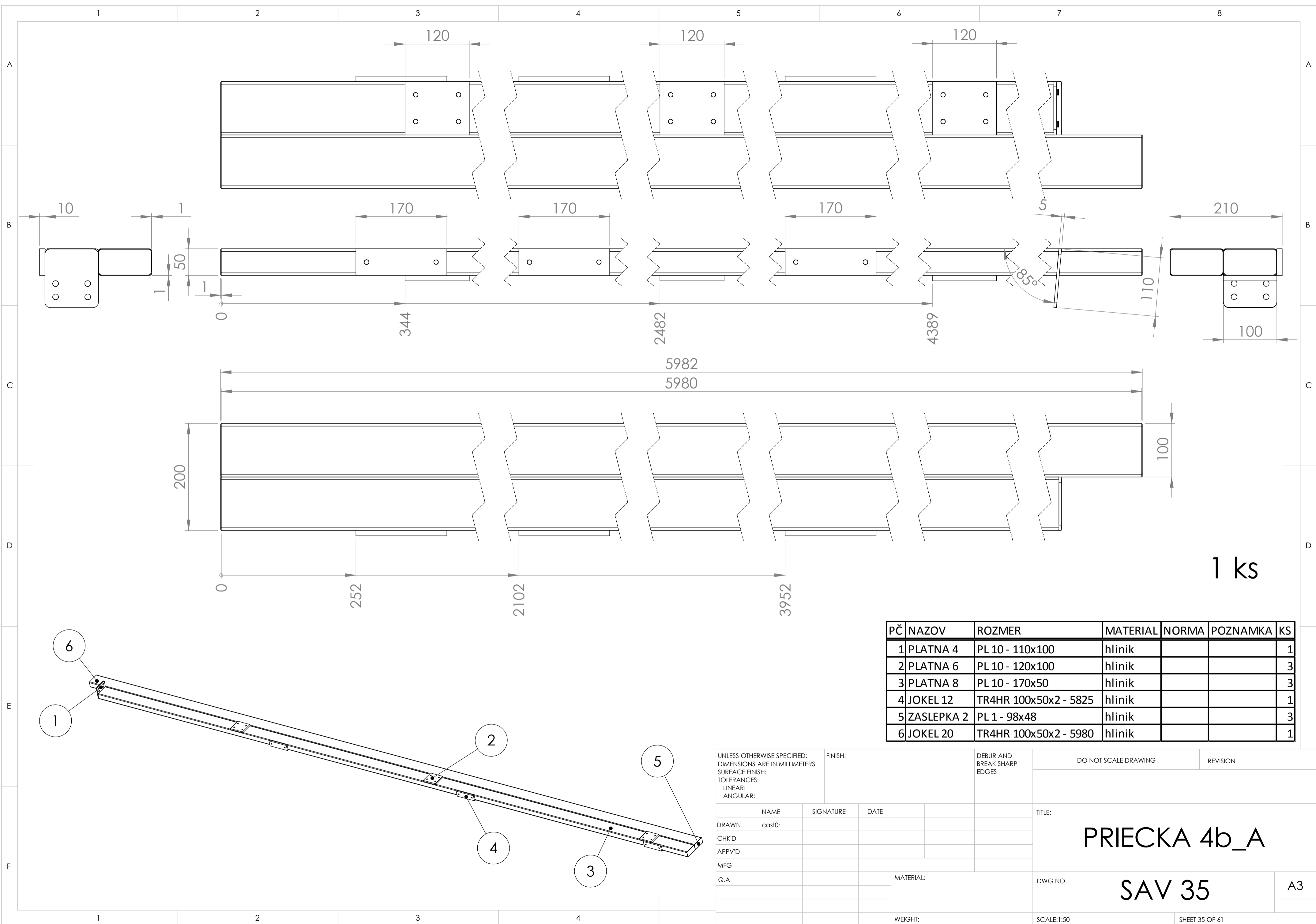

1 ks

PČ	NAZOV	ROZMER	MATERIAL	NORMA	POZNAMKA	KS
1	PLATNA 4	PL 10 - 110x100	hlinik			1
2	PLATNA 6	PL 10 - 120x100	hlinik			3
3	PLATNA 8	PL 10 - 170x50	hlinik			3
4	JOKEL 12	TR4HR 100x50x2 - 5825	hlinik			1
5	ZASLEPKA 2	PL 1 - 98x48	hlinik			3
6	JOKEL 20	TR4HR 100x50x2 - 5980	hlinik			1

UNLESS OTHERWISE SPECIFIED:
 DIMENSIONS ARE IN MILLIMETERS
 SURFACE FINISH:
 TOLERANCES:
 LINEAR:
 ANGULAR:

FINISH:

DEBUR AND BREAK SHARP EDGES

DO NOT SCALE DRAWING

REVISION

NAME	SIGNATURE	DATE
DRAWN	cast0r	
CHK'D		
APPV'D		
MFG		
Q.A		

TITLE:
PRIECKA 4b_A

DWG NO.:
SAV 35

SCALE:1:50

SHEET 35 OF 61

A3

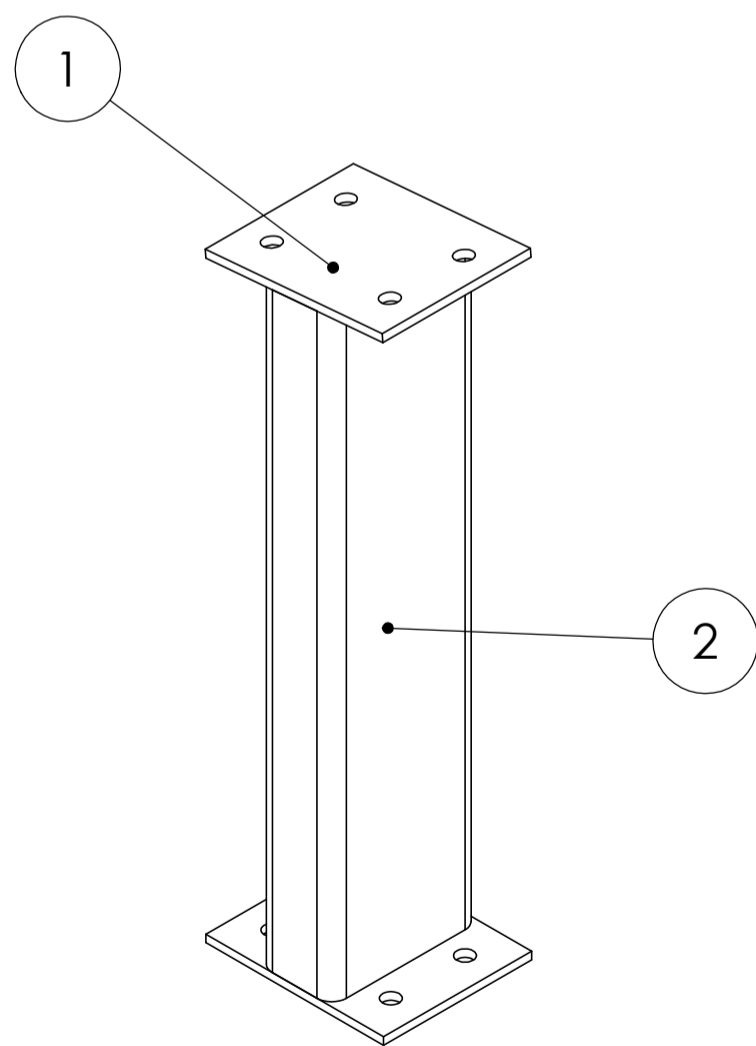
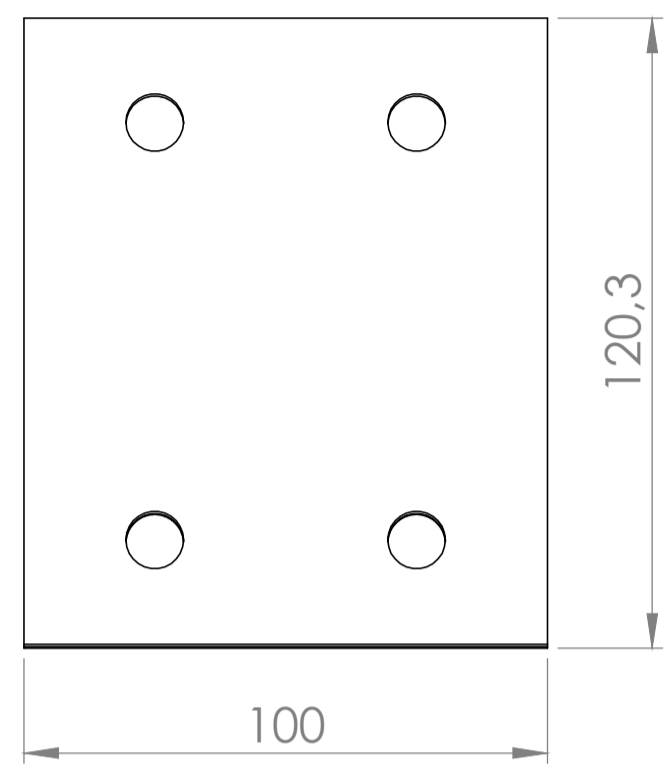

3 ks

PČ	NAZOV	ROZMER	MATERIAL	NORMA	POZNAMKA	KS
1	PLATNA 7	PL 5 - 100x120	hlinik			2
2	JOKEĽ 16	TR4HR 100x50x2 - 402,5	hlinik			1

UNLESS OTHERWISE SPECIFIED: DIMENSIONS ARE IN MILLIMETERS SURFACE FINISH: TOLERANCES: LINEAR: ANGULAR:			FINISH:		DEBUR AND BREAK SHARP EDGES		DO NOT SCALE DRAWING		REVISION	
NAME	SIGNATURE	DATE			TITLE:					
DRAWN	castOr				<h1>VYSTUHA 4</h1>					
CHK'D										
APPV'D										
MFG										
Q.A			MATERIAL:		DWG NO.		SAV 37		A3	
			WEIGHT:		SCALE:1:2		SHEET 37 OF 61			

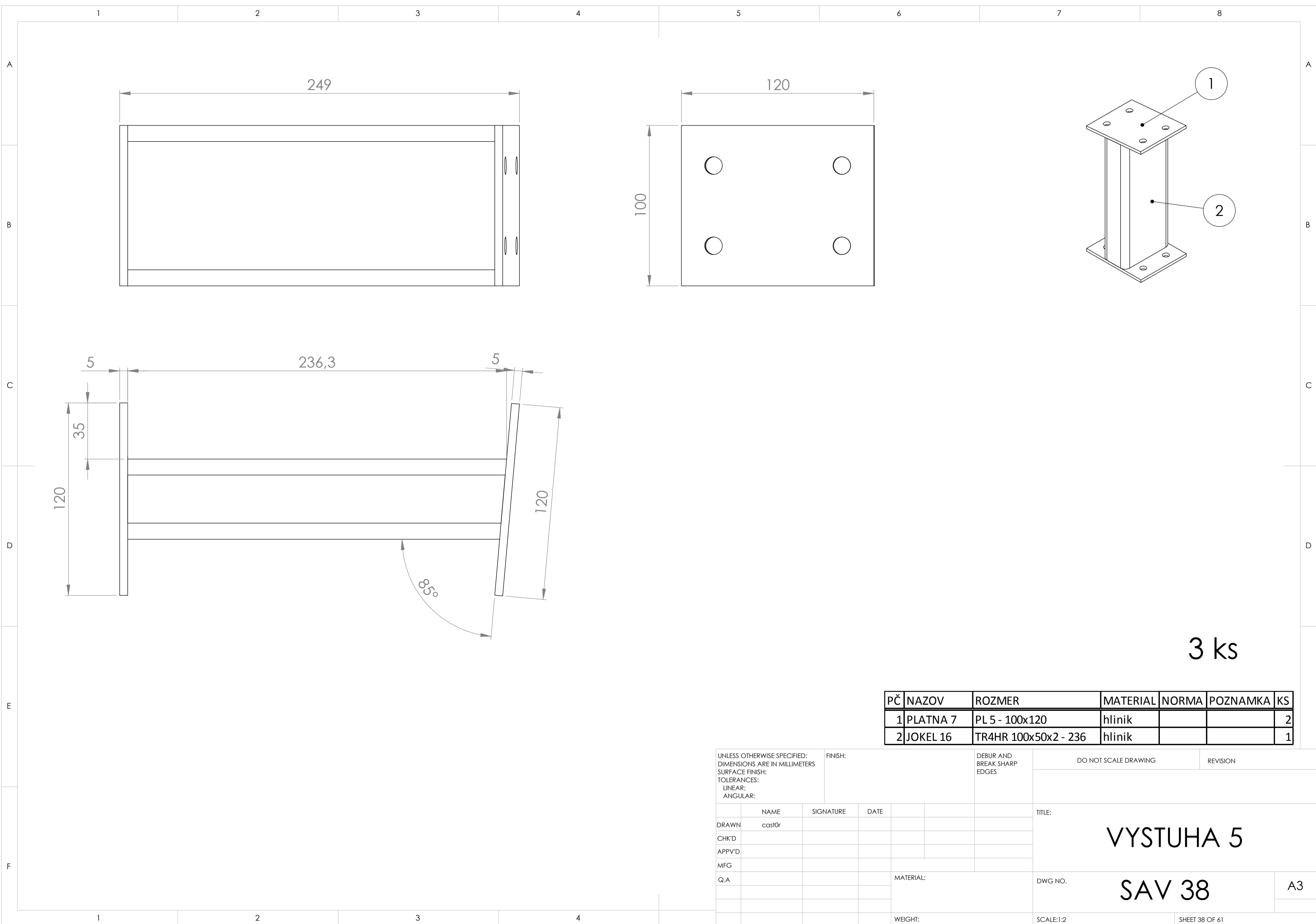

3 ks

PČ	NAZOV	ROZMER	MATERIAL	NORMA	POZNAMKA	KS
1	PLATNA 7	PL 5 - 100x120	hlinik			2
2	JOKEL 16	TR4HR 100x50x2 - 236	hlinik			1

UNLESS OTHERWISE SPECIFIED: DIMENSIONS ARE IN MILLIMETERS SURFACE FINISH: TOLERANCES: LINEAR: ANGULAR:			FINISH:		DEBUR AND BREAK SHARP EDGES		DO NOT SCALE DRAWING		REVISION	
NAME	SIGNATURE	DATE							TITLE:	
DRAWN cast0r									<h1>VYSTUHA 5</h1> <h2>SAV 38</h2>	
CHK'D										
APPV'D										
MFG										
Q.A					MATERIAL:		DWG NO.		A3	
					WEIGHT:		SCALE:1:2		SHEET 38 OF 61	

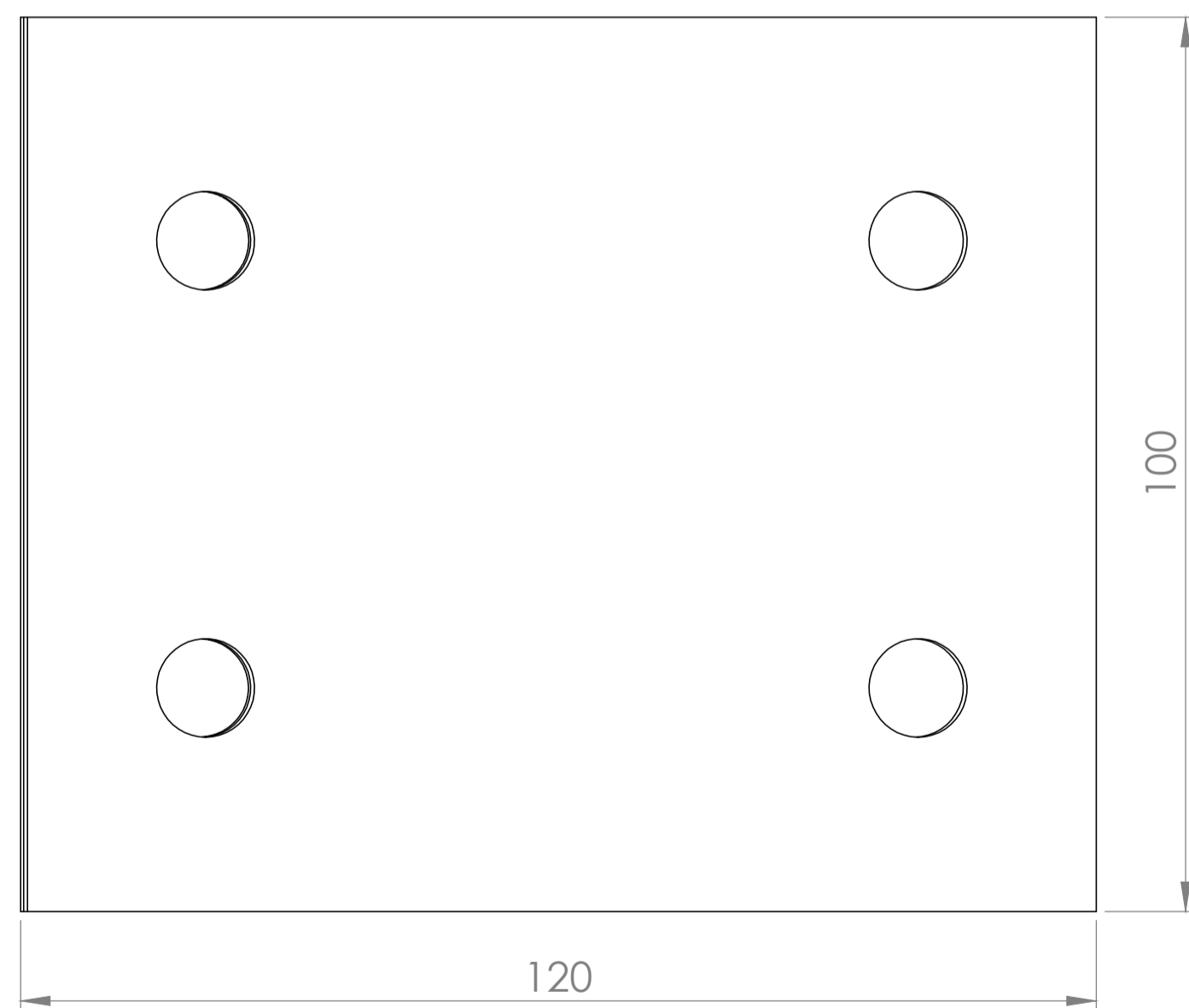
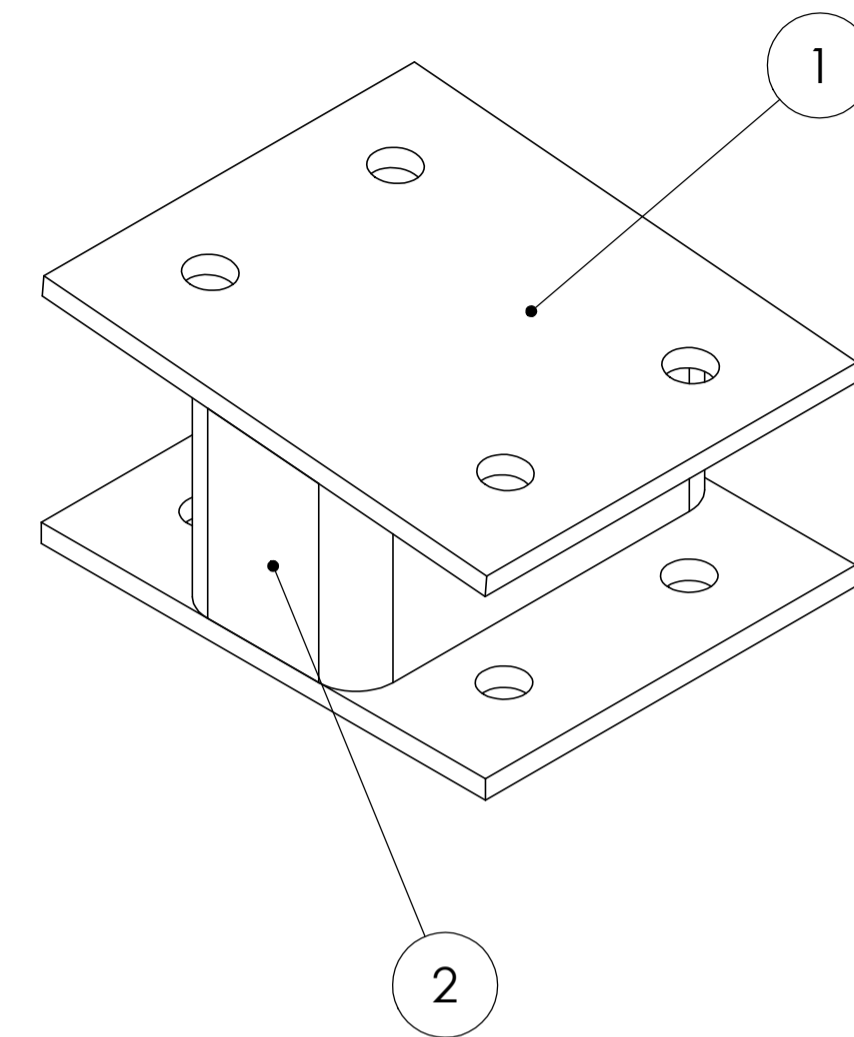
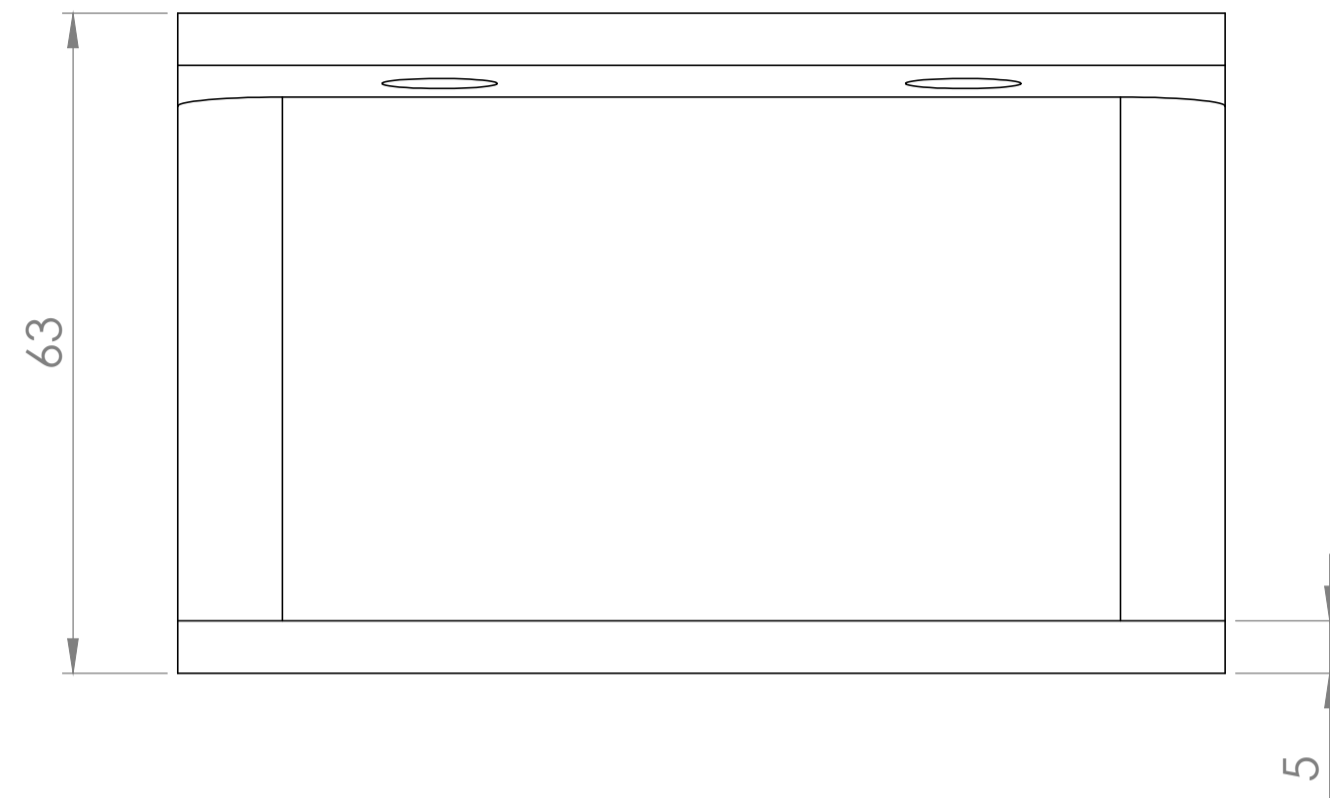
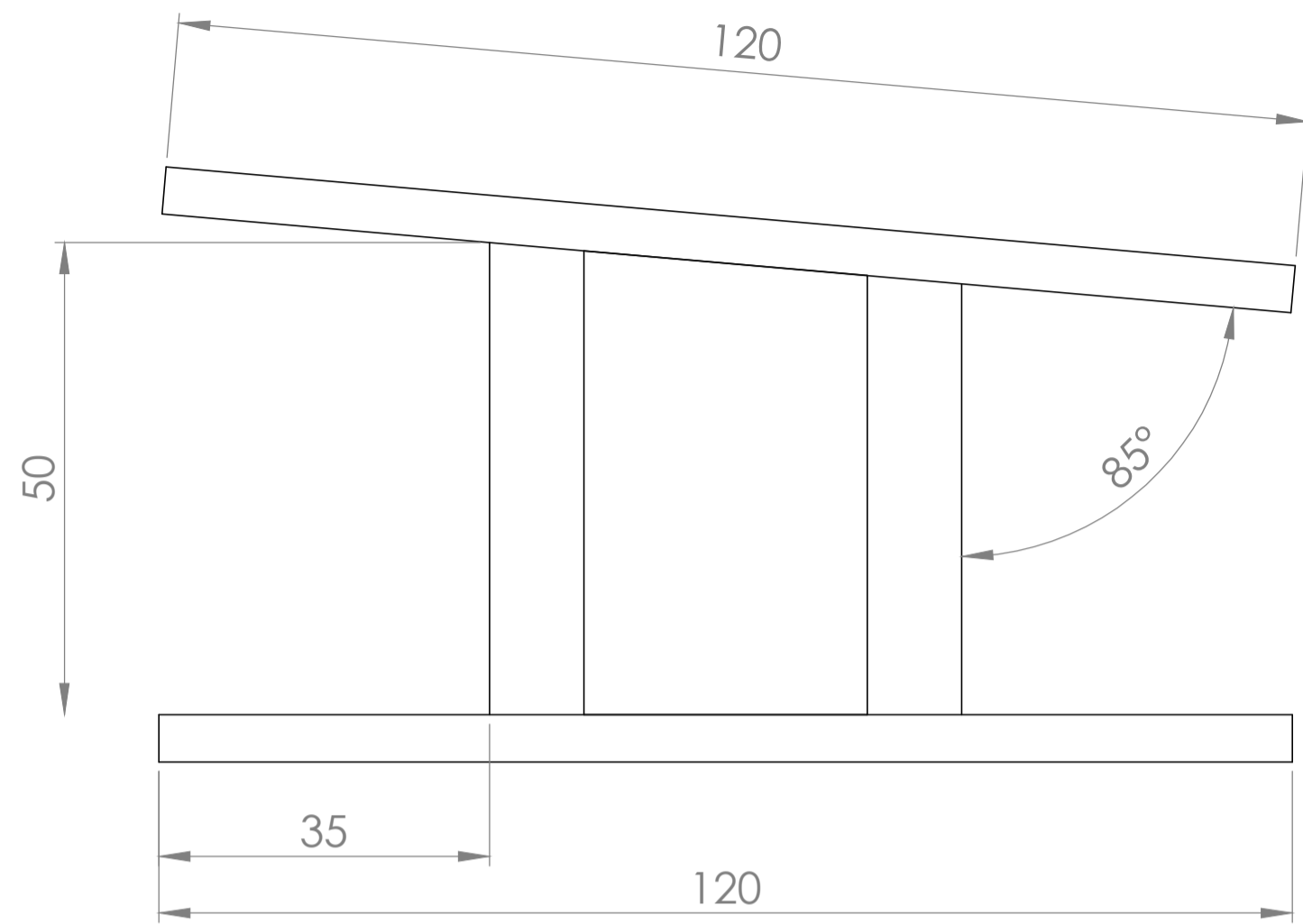

3 ks

PČ	NAZOV	ROZMER	MATERIAL	NORMA	POZNAMKA	KS
1	PLATNA 7	PL 5 - 100x120	hlinik			2
2	JOKEL 16	TR4HR 100x50x2 - 50	hlinik			1

UNLESS OTHERWISE SPECIFIED: DIMENSIONS ARE IN MILLIMETERS SURFACE FINISH: TOLERANCES: LINEAR: ANGULAR:			FINISH:		DEBUR AND BREAK SHARP EDGES		DO NOT SCALE DRAWING		REVISION	
NAME	SIGNATURE	DATE				TITLE:		<h1>VYSTUHA 6</h1> <h2>SAV 39</h2>		
DRAWN	cast0r					DWG NO.				
CHK'D						SCALE:1:1				
APPV'D						SHEET 39 OF 61				
MFG										
Q.A			MATERIAL:					A3		
			WEIGHT:							

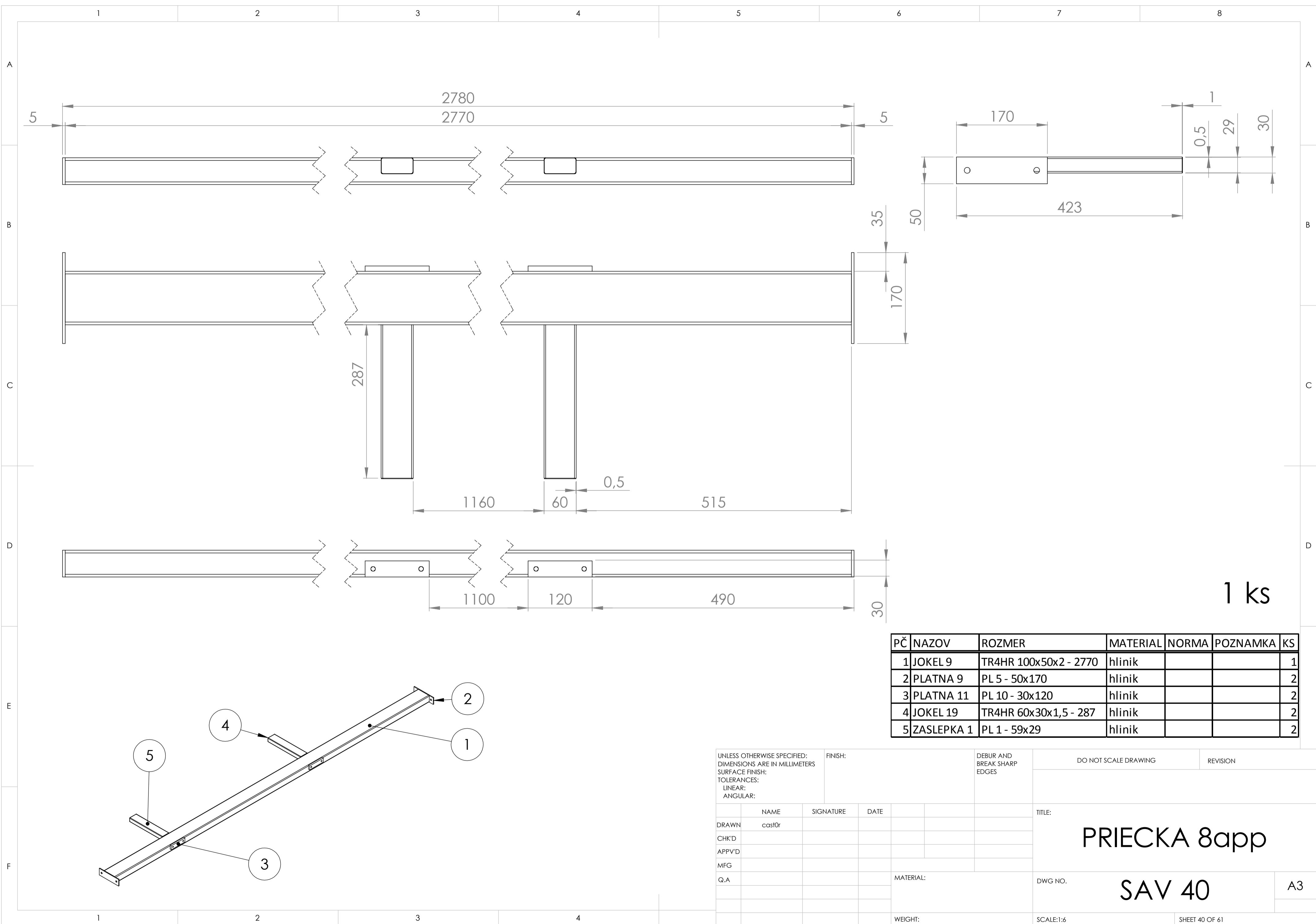

UNLESS OTHERWISE SPECIFIED: DIMENSIONS ARE IN MILLIMETERS SURFACE FINISH: TOLERANCES: LINEAR: ANGULAR:			FINISH:	DEBUR AND BREAK SHARP EDGES	DO NOT SCALE DRAWING	REVISION
DRAWN	NAME	SIGNATURE	DATE		TITLE: PRIECKA 8app	
CHK'D	cast0r				DWG NO. SAV 40	
APPV'D					A3	
MFG				MATERIAL:	SCALE:1:6	
Q.A				WEIGHT:	SHEET 40 OF 61	

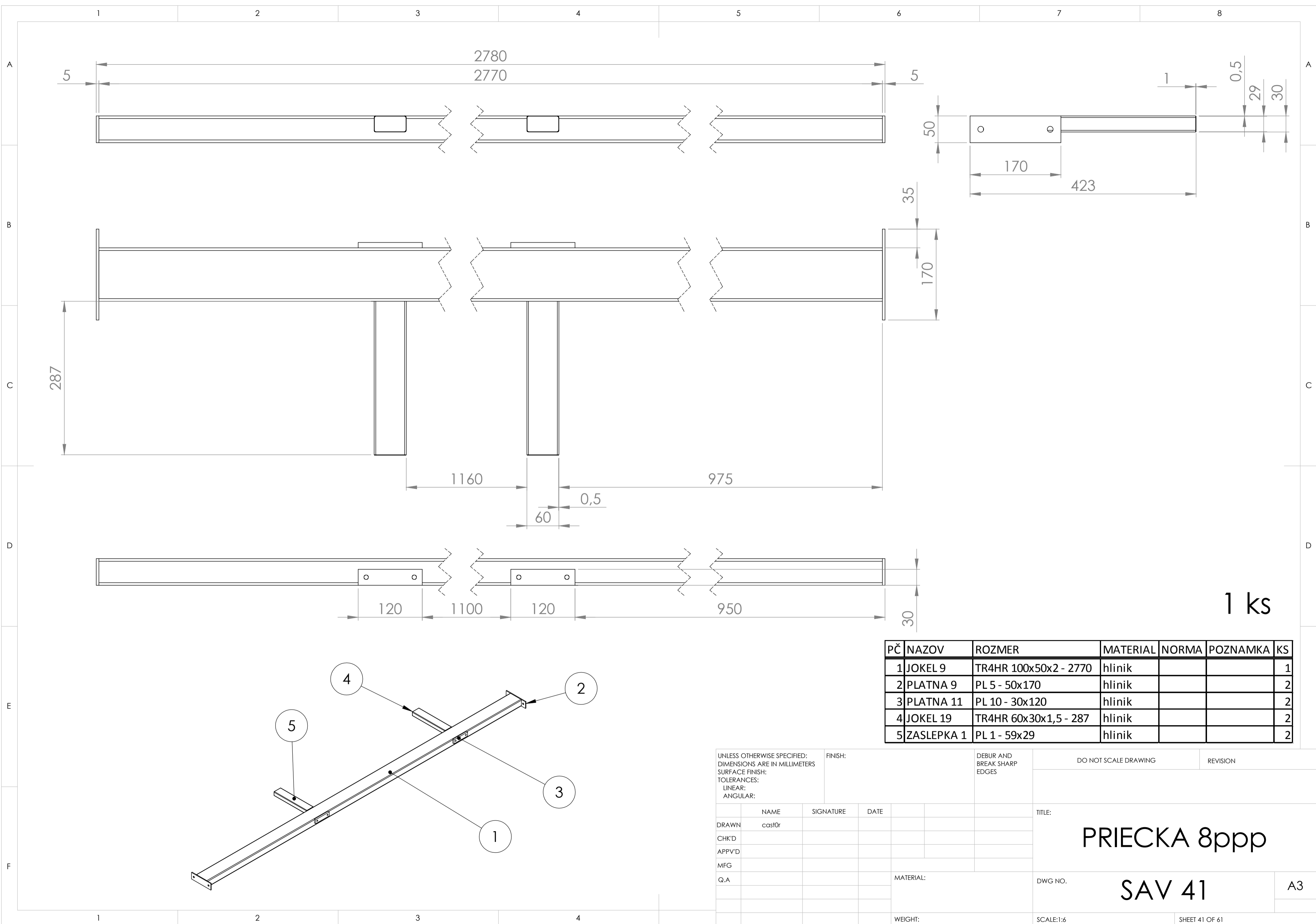

1 ks

PČ	NAZOV	ROZMER	MATERIAL	NORMA	POZNAMKA	KS
1	JOKEL 9	TR4HR 100x50x2 - 2770	hlinik			1
2	PLATNA 9	PL 5 - 50x170	hlinik			2
3	PLATNA 11	PL 10 - 30x120	hlinik			2
4	JOKEL 19	TR4HR 60x30x1,5 - 287	hlinik			2
5	ZASLEPKA 1	PL 1 - 59x29	hlinik			2

UNLESS OTHERWISE SPECIFIED:
 DIMENSIONS ARE IN MILLIMETERS
 SURFACE FINISH:
 TOLERANCES:
 LINEAR:
 ANGULAR:

FINISH:

DEBUR AND
 BREAK SHARP
 EDGES

DO NOT SCALE DRAWING

REVISION

	NAME	SIGNATURE	DATE
DRAWN	cast0r		
CHK'D			
APPV'D			
MFG			
Q.A			

TITLE: PRIECKA 8ppp	
DWG NO. SAV 41	A3
SCALE:1:6	SHEET 41 OF 61

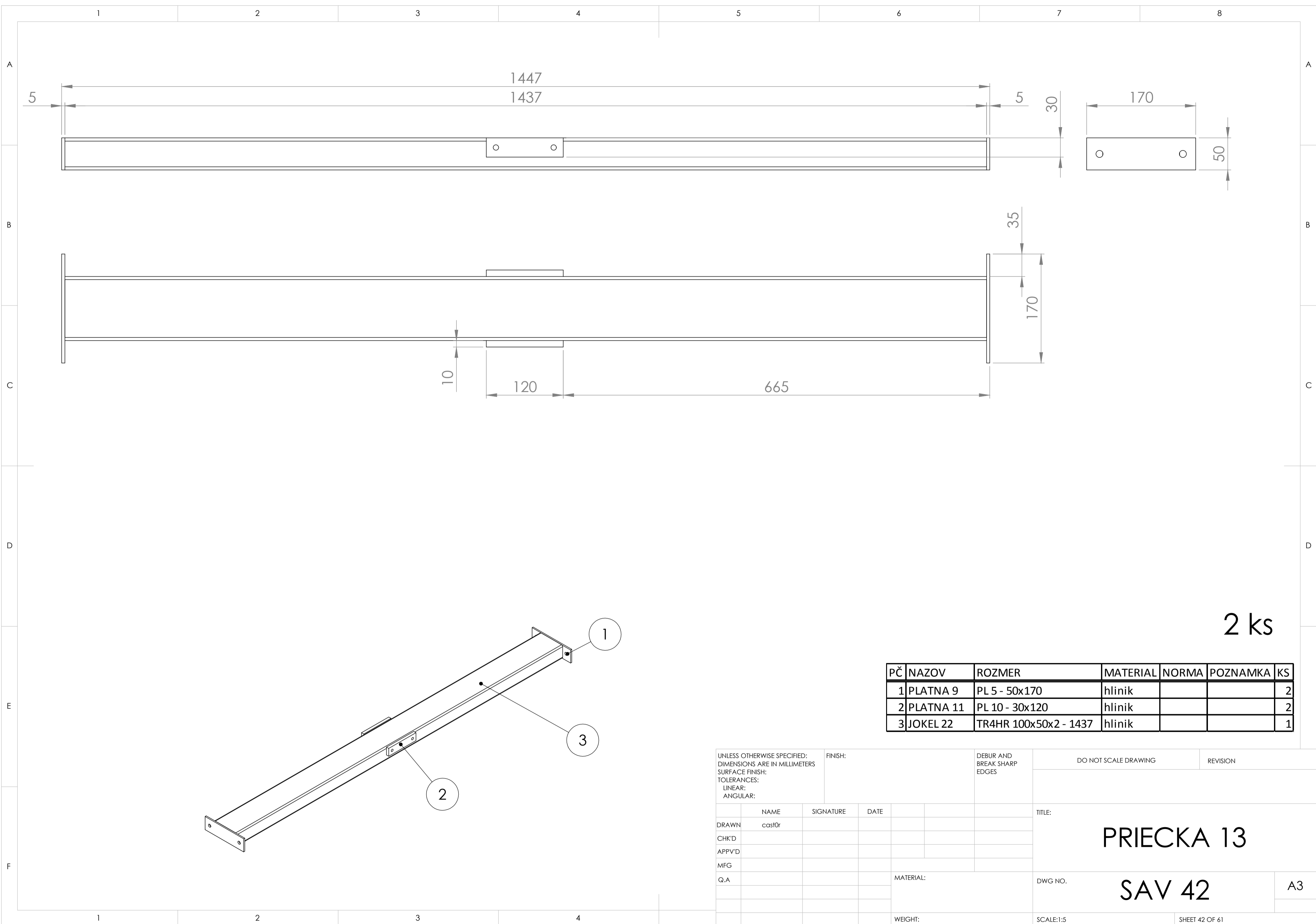

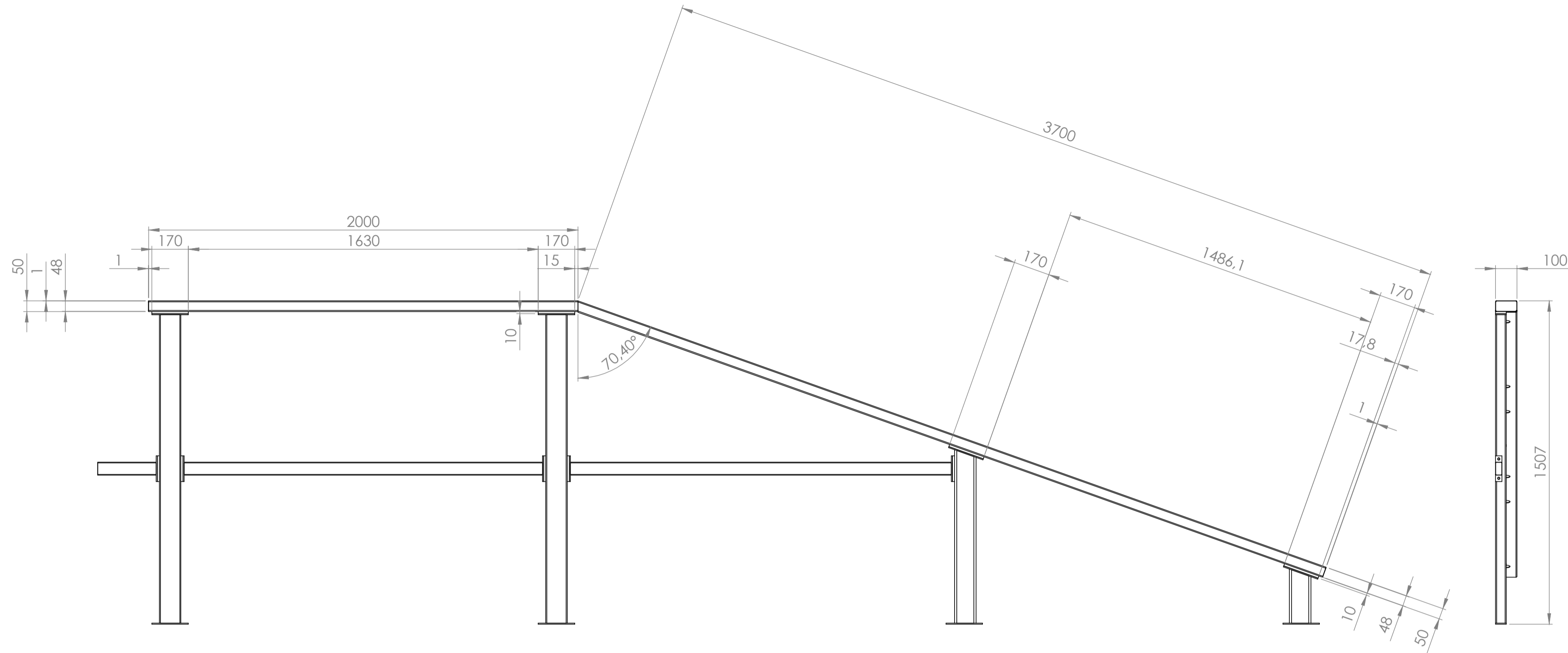

1 ks

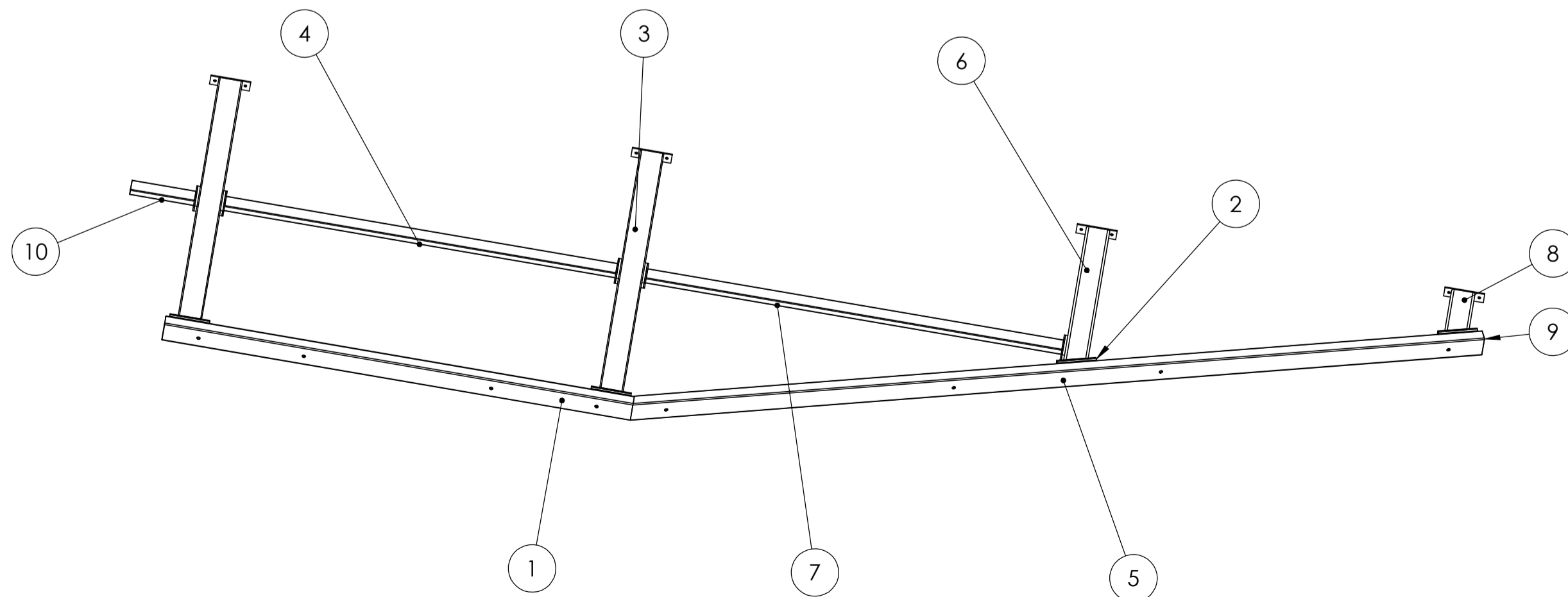

PČ	NAZOV	ROZMER	MATERIAL	NORMA	POZNAMKA	KS
1	JOKEL 21	TR4HR 100x50x2 - 2000	hlinik			1
2	PLATNA 8	PL 10 - 170x50	hlinik			4
3	PRIECKA 13					2
4	PRIECKA 14					1
5	JOKEL 21a	TR4HR 100x50x2 - 3700	hlinik			1
6	PRIECKA 13a					1
7	PRIECKA 16					1
8	PRIECKA 13ab					1
9	ZASLEPKA 2	PL 1 - 98x48	hlinik			2
10	PRIECKA 17					1
11	SKRUTKA	M10x16		DIN 912		26
12	PODLOZKA	M10		DIN 125-A		26
13	Guma 5	1670		GUMA 1 - EPDM	http://www.tercomontbb.sk	1
14	Guma 6	1775		GUMA 1 - EPDM	http://www.tercomontbb.sk	1
15	Guma 7	272		GUMA 1 - EPDM	http://www.tercomontbb.sk	1

UNLESS OTHERWISE SPECIFIED: DIMENSIONS ARE IN MILLIMETERS
 FINISH: SURFACE FINISH: TOLERANCES: LINEAR: ANGULAR:
 DEBUR AND BREAK SHARP EDGES
 DO NOT SCALE DRAWING
 REVISION

NAME	SIGNATURE	DATE	TITLE:
DRAWN: cas30r			ZOSTAVA 3
CHKD:			
APPVD:			
MFG:			
Q.A:			

MATERIAL: DWG NO. **SAV 43** A2
 WEIGHT: SCALE:1:15 SHEET 43 OF 61

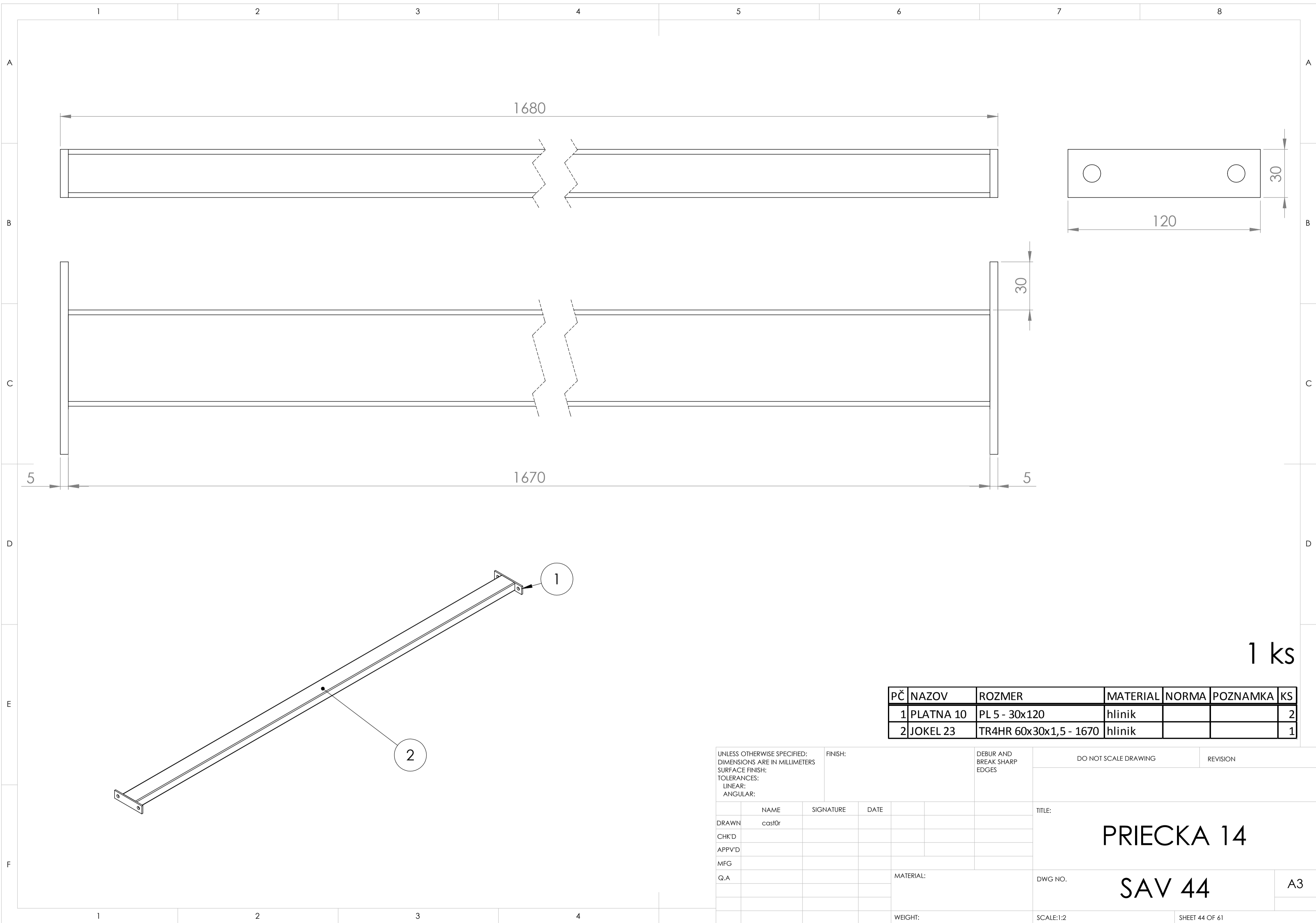

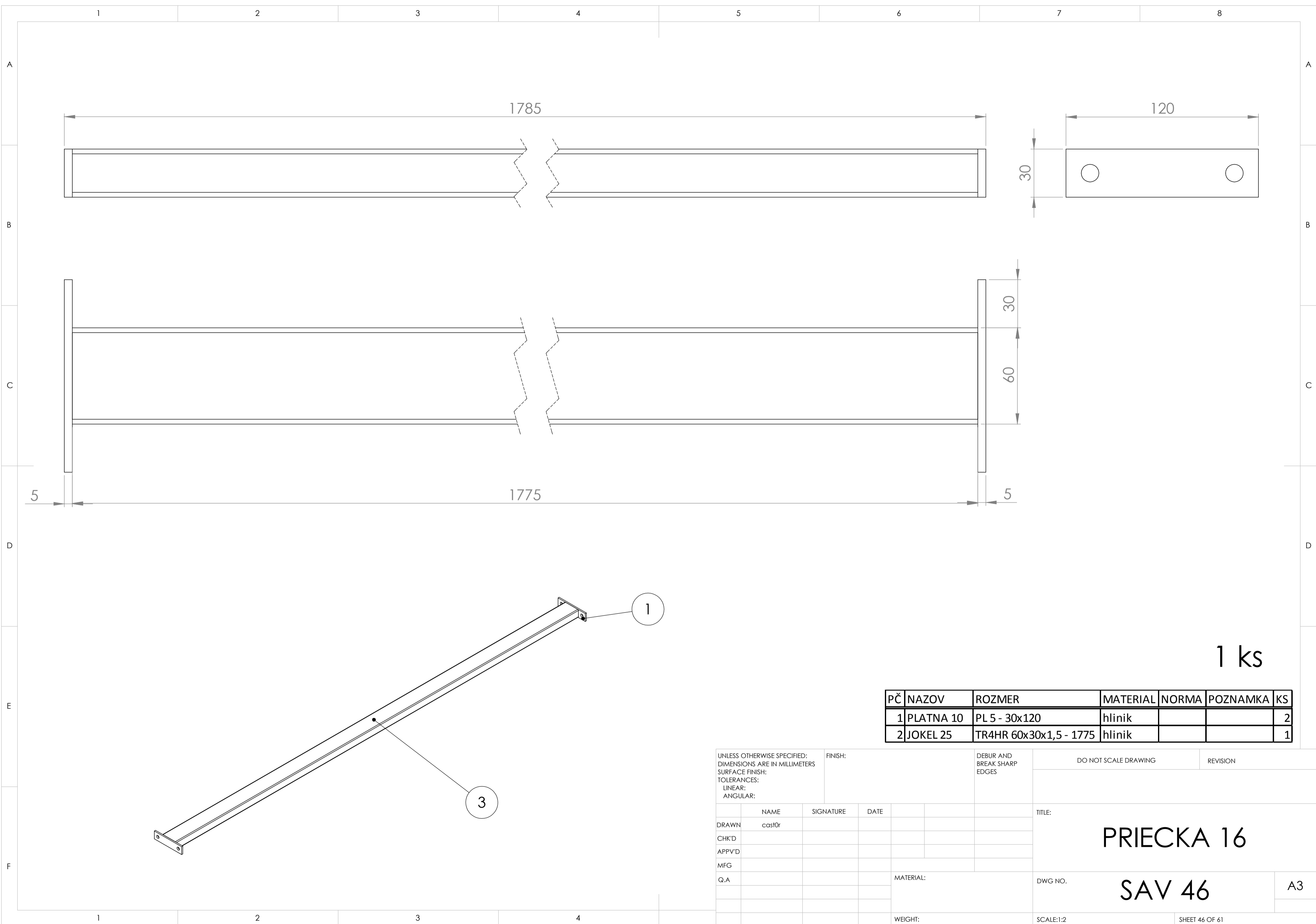

PČ	NAZOV	ROZMER	MATERIAL	NORMA	POZNAMKA	KS
1	PLATNA 10	PL 5 - 30x120	hlinik			2
2	JOKEL 25	TR4HR 60x30x1,5 - 1775	hlinik			1

UNLESS OTHERWISE SPECIFIED: DIMENSIONS ARE IN MILLIMETERS SURFACE FINISH: TOLERANCES: LINEAR: ANGULAR:				FINISH:		DEBUR AND BREAK SHARP EDGES		DO NOT SCALE DRAWING		REVISION	
DRAWN		NAME		SIGNATURE		DATE		TITLE:			
CHK'D		cast0r						PRIECKA 16			
APPV'D											
MFG								DWG NO.		A3	
Q.A								SCALE:1:2		SHEET 46 OF 61	
								WEIGHT:			

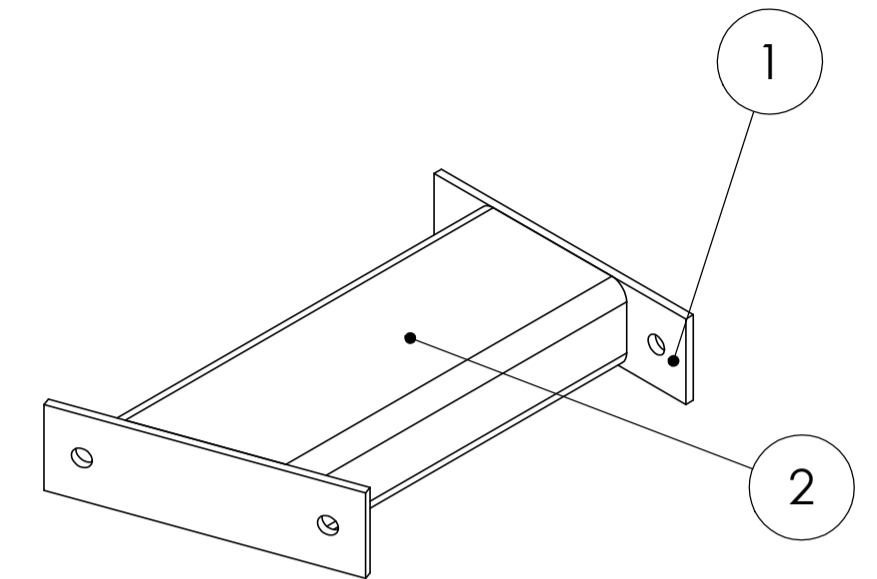
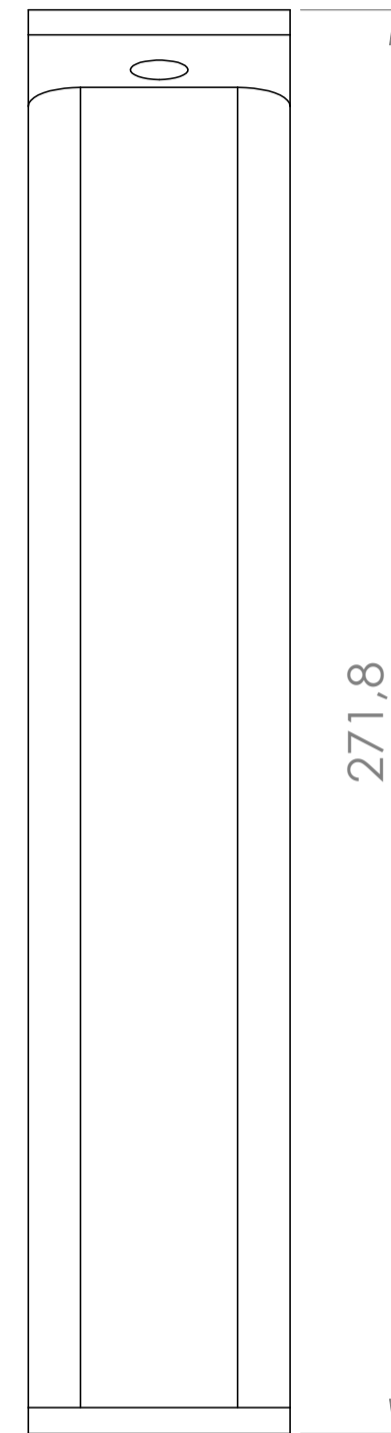
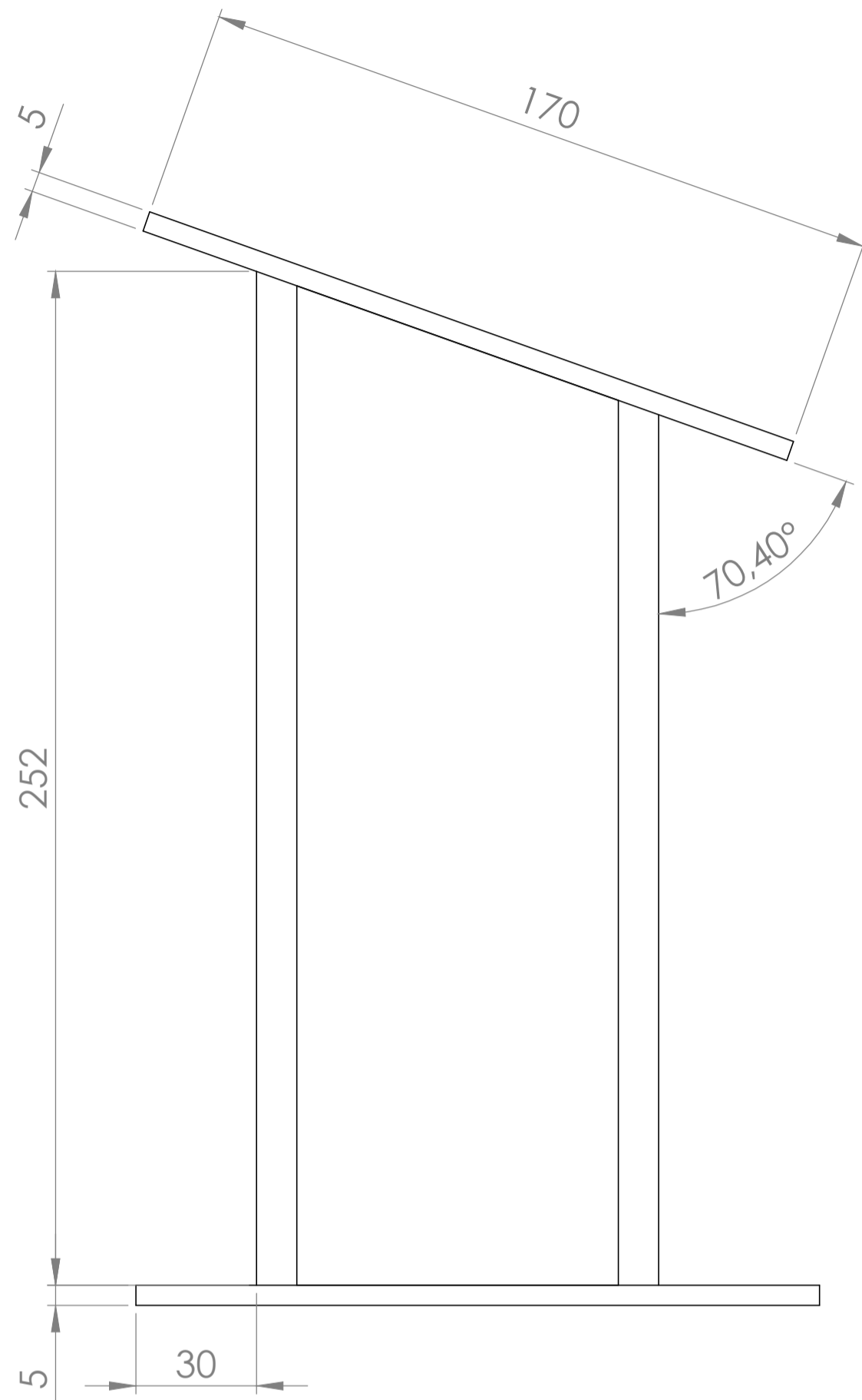

1 ks



PČ	NAZOV	ROZMER	MATERIAL	NORMA	POZNAMKA	KS
1	PLATNA 9	PL 5 - 50x170	hlinik			2
2	JOKEĽ 22	TR4HR 100x50x2 - 252	hlinik			1

UNLESS OTHERWISE SPECIFIED: DIMENSIONS ARE IN MILLIMETERS SURFACE FINISH: TOLERANCES: LINEAR: ANGULAR:			FINISH:		DEBUR AND BREAK SHARP EDGES		DO NOT SCALE DRAWING		REVISION	
NAME	SIGNATURE	DATE				TITLE: PRIECKA 13ab				
DRAWN cast0r						DWG NO. SAV 47				
CHK'D						SCALE:1:2				
APPV'D						SHEET 47 OF 61				
MFG						A3				
Q.A			MATERIAL:							
			WEIGHT:							

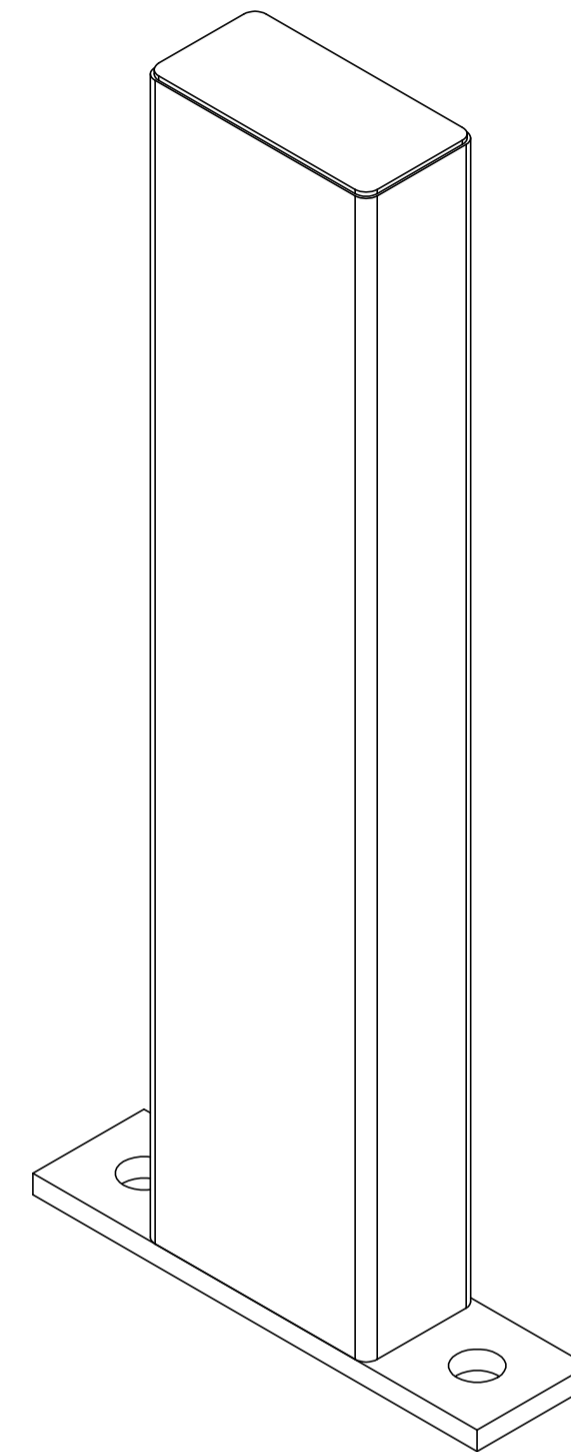
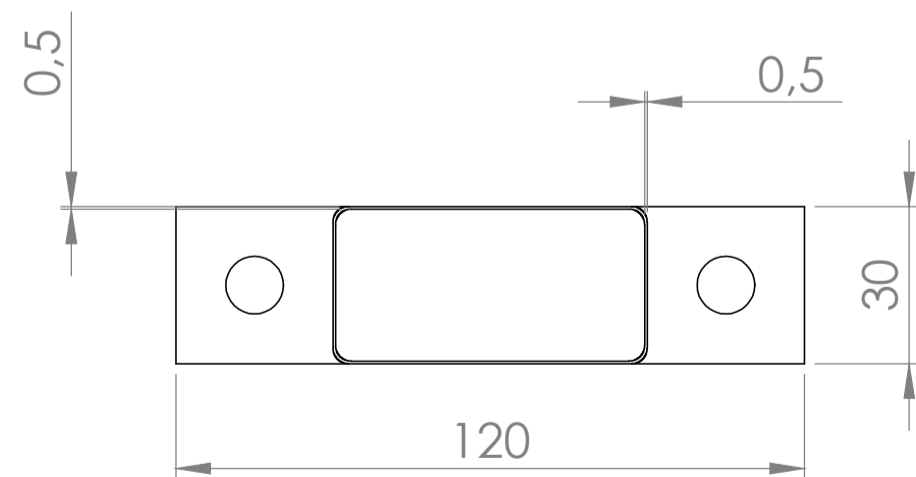
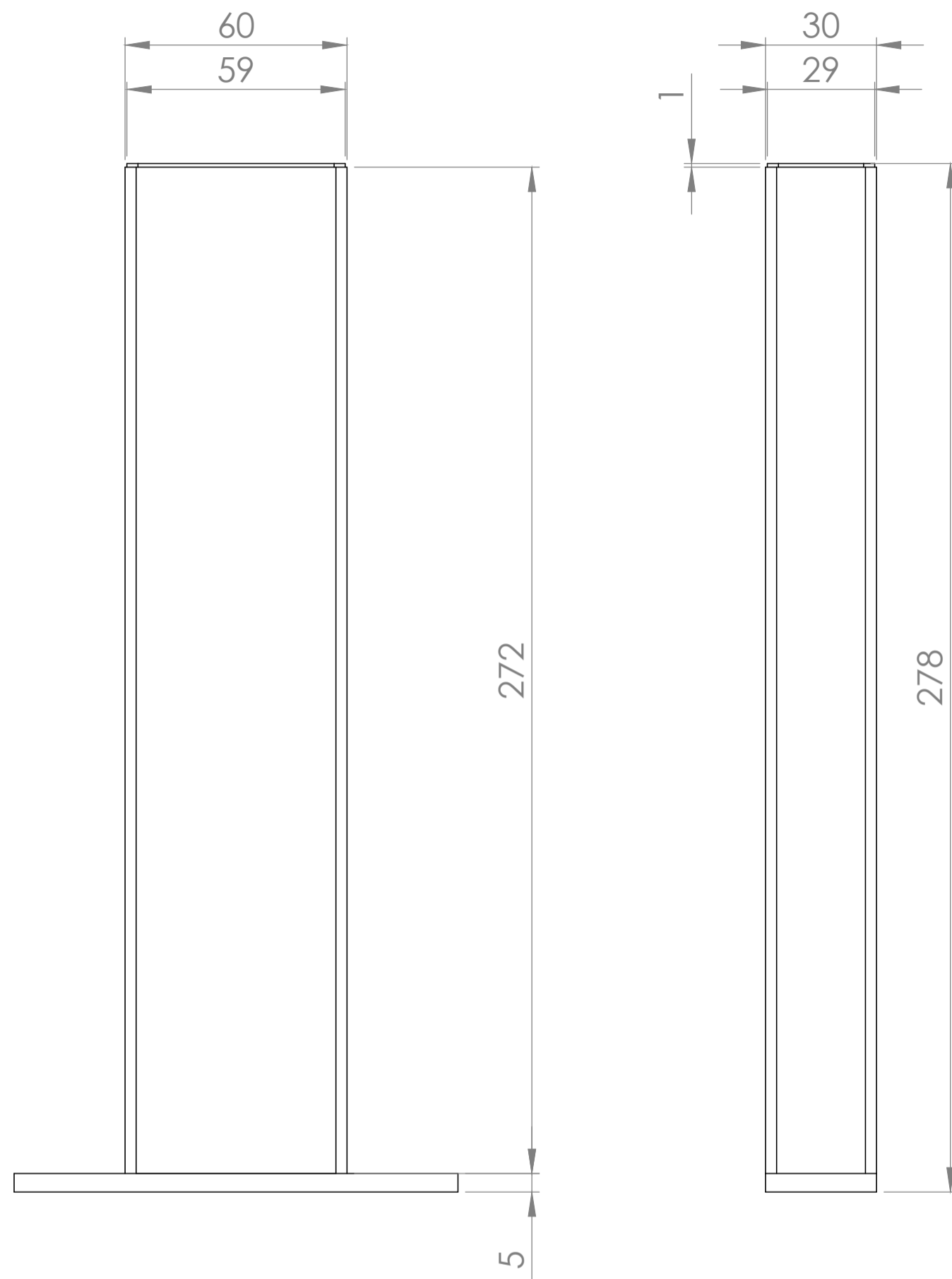

PČ	NAZOV	ROZMER	MATERIAL	NORMA	POZNAMKA	KS
1	ZASLEPKA 1	PL 1 - 59x29	hlinik			1
2	PLATNA 10	PL 5 - 30x120	hlinik			1
2	JOKEL 26	TR4HR 60x30x1,5 - 272	hlinik			1

UNLESS OTHERWISE SPECIFIED: DIMENSIONS ARE IN MILLIMETERS SURFACE FINISH: TOLERANCES: LINEAR: ANGULAR:			FINISH:		DEBUR AND BREAK SHARP EDGES		DO NOT SCALE DRAWING		REVISION	
NAME	SIGNATURE	DATE				TITLE:				
DRAWN	cast0r					<h1>PRIECKA 17</h1>				
CHK'D										
APPV'D										
MFG										
Q.A			MATERIAL:			DWG NO.		<h1>SAV 48</h1>		A3
			WEIGHT:			SCALE:1:2				

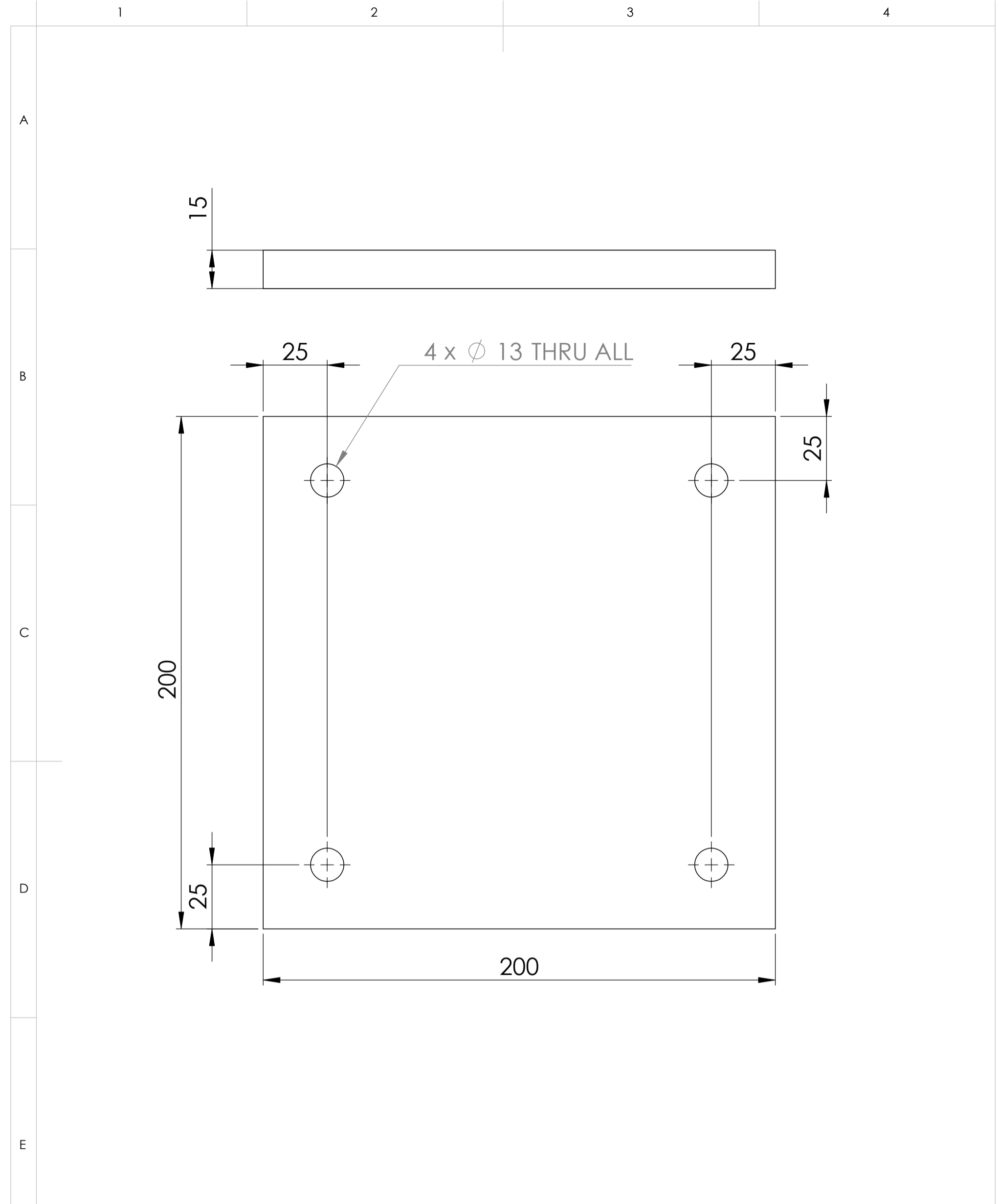

UNLESS OTHERWISE SPECIFIED: DIMENSIONS ARE IN MILLIMETERS SURFACE FINISH: TOLERANCES: LINEAR: ANGULAR:		FINISH:		DEBUR AND BREAK SHARP EDGES		DO NOT SCALE DRAWING		REVISION	
						TITLE: PLATNA 1			
DRAWN	NAME	SIGNATURE	DATE						
CHK'D	cas10r								
APP'VD									
MFG						DWG NO. SAV 49		A4	
Q.A				MATERIAL:					
				WEIGHT:		SCALE:1:2		SHEET 49 OF 61	

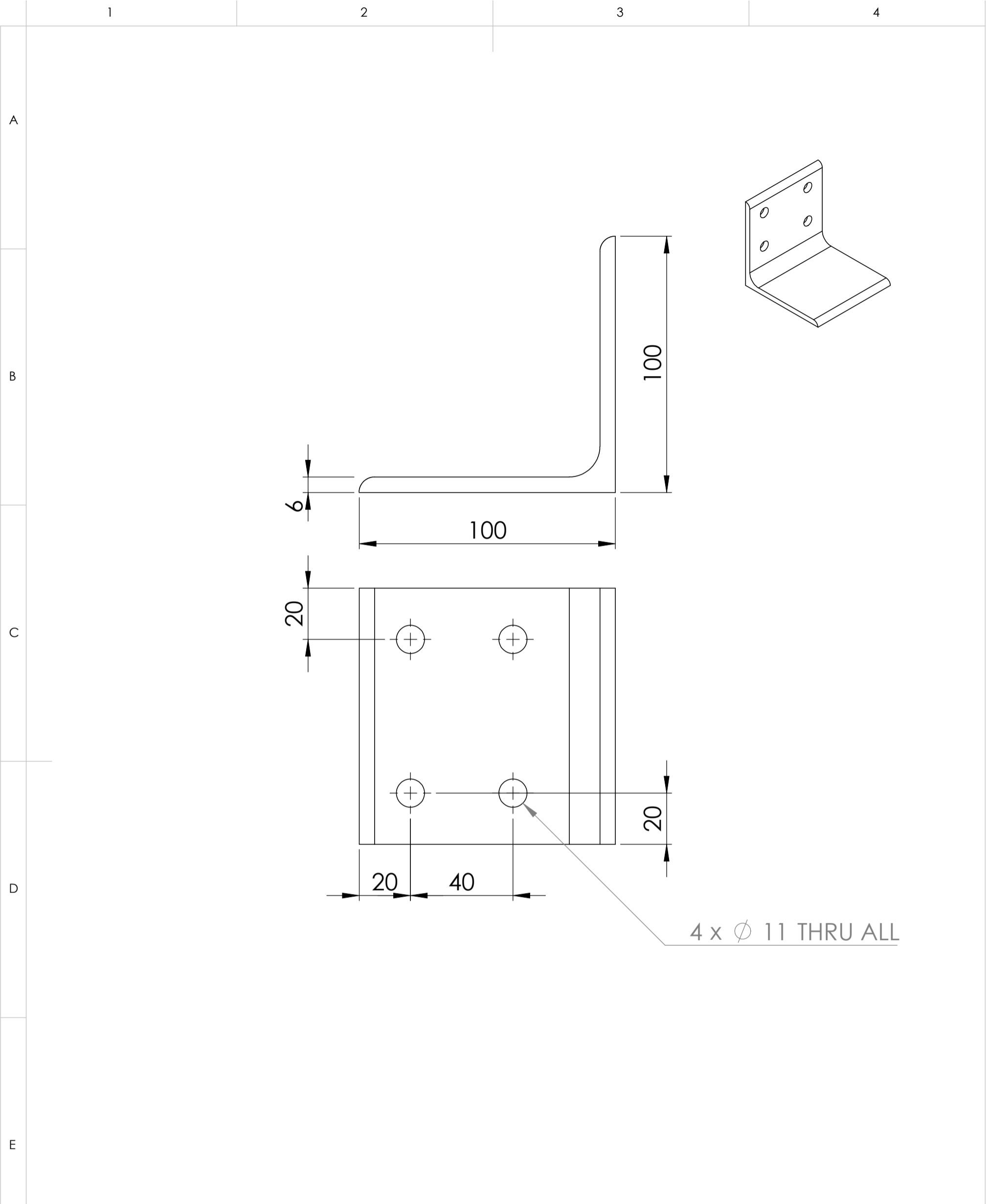

UNLESS OTHERWISE SPECIFIED: DIMENSIONS ARE IN MILLIMETERS		FINISH:		DEBUR AND BREAK SHARP EDGES		DO NOT SCALE DRAWING		REVISION	
SURFACE FINISH:									
TOLERANCES:									
LINEAR:									
ANGULAR:									
	NAME	SIGNATURE	DATE			TITLE: L1			
DRAWN	cast0r								
CHK'D									
APP'VD									
F MFG									
Q.A				MATERIAL:		DWG NO.		A4	
						SAV 50			
				WEIGHT:		SCALE:1:2		SHEET 50 OF 61	

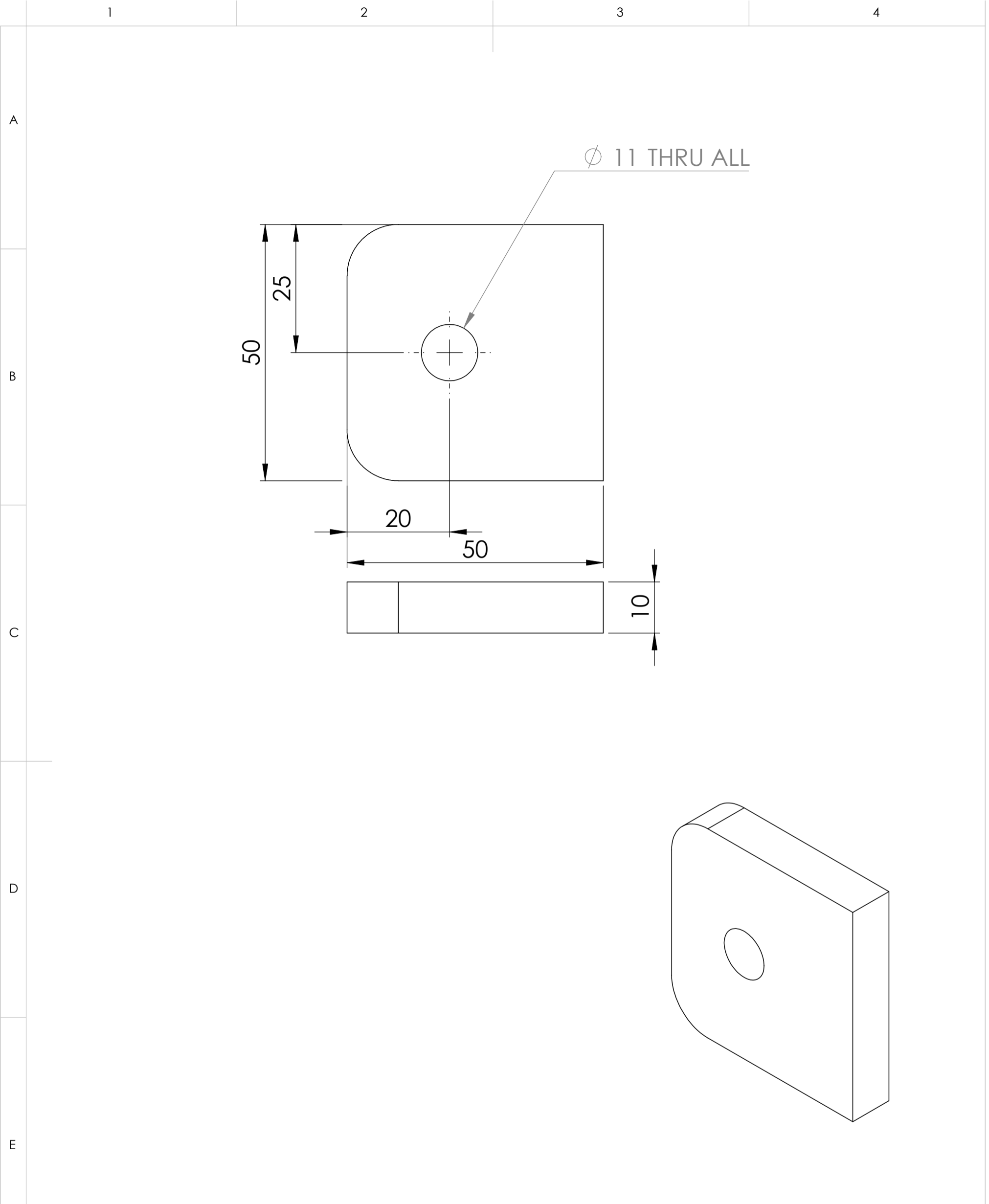

UNLESS OTHERWISE SPECIFIED: DIMENSIONS ARE IN MILLIMETERS SURFACE FINISH: TOLERANCES: LINEAR: ANGULAR:		FINISH:		DEBUR AND BREAK SHARP EDGES		DO NOT SCALE DRAWING		REVISION	
	NAME	SIGNATURE	DATE			TITLE: PRIRUBA 1			
DRAWN	cas10r								
CHK'D									
APP'VD									
MFG									
Q.A				MATERIAL:		DWG NO.		A4	
				WEIGHT:		SCALE:1:1		SHEET 51 OF 61	

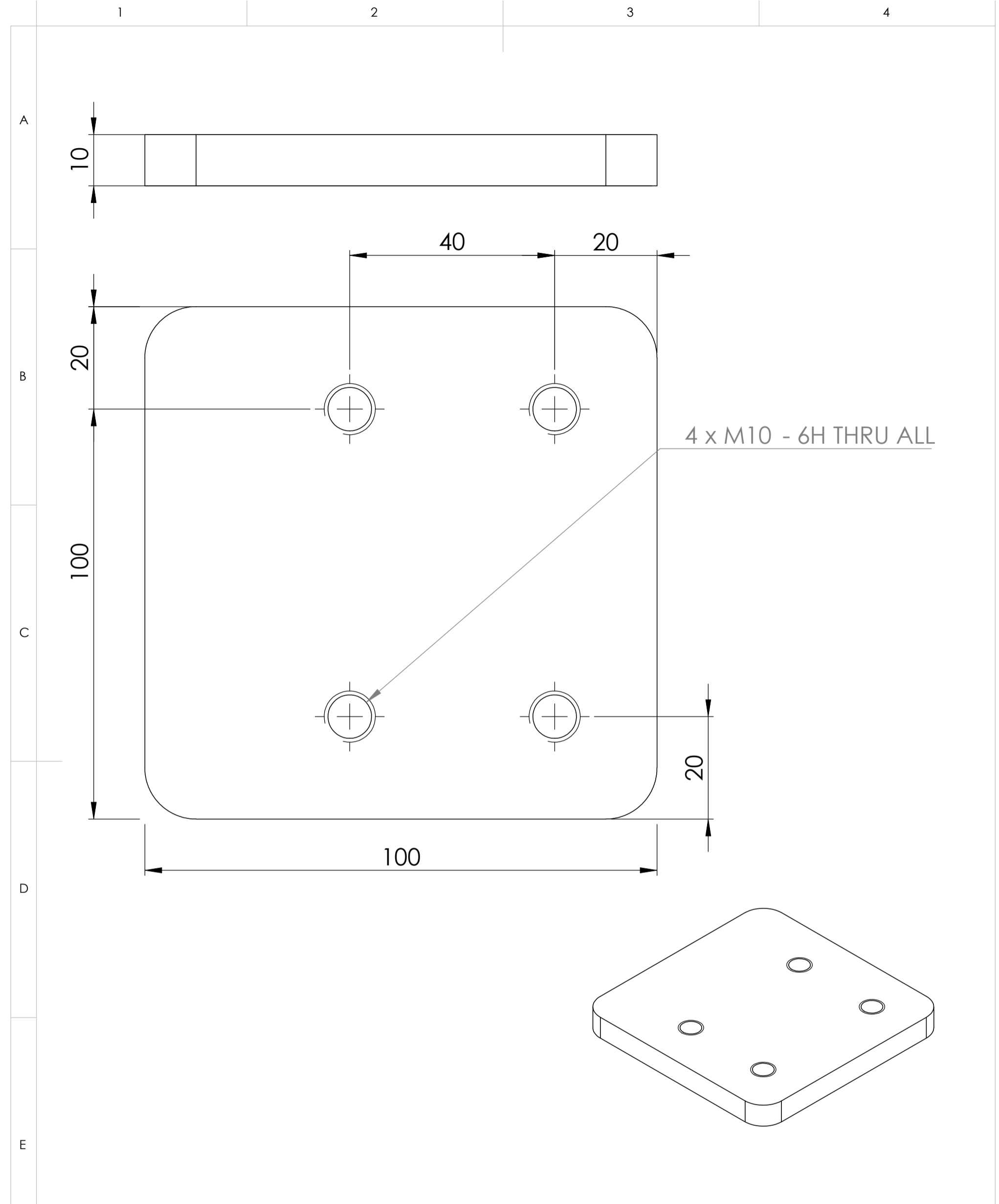

UNLESS OTHERWISE SPECIFIED: DIMENSIONS ARE IN MILLIMETERS SURFACE FINISH: TOLERANCES: LINEAR: ANGULAR:				FINISH:		DEBUR AND BREAK SHARP EDGES		DO NOT SCALE DRAWING		REVISION			
								<p>TITLE:</p> <h1>PLATNA 2</h1>					
DRAWN		NAME		SIGNATURE		DATE							
CHK'D													
APPV'D													
MFG													
Q.A								MATERIAL:		DWG NO.			
										SAV 52			
								WEIGHT:		SCALE:1:1			
										SHEET 52 OF 61			
										A4			

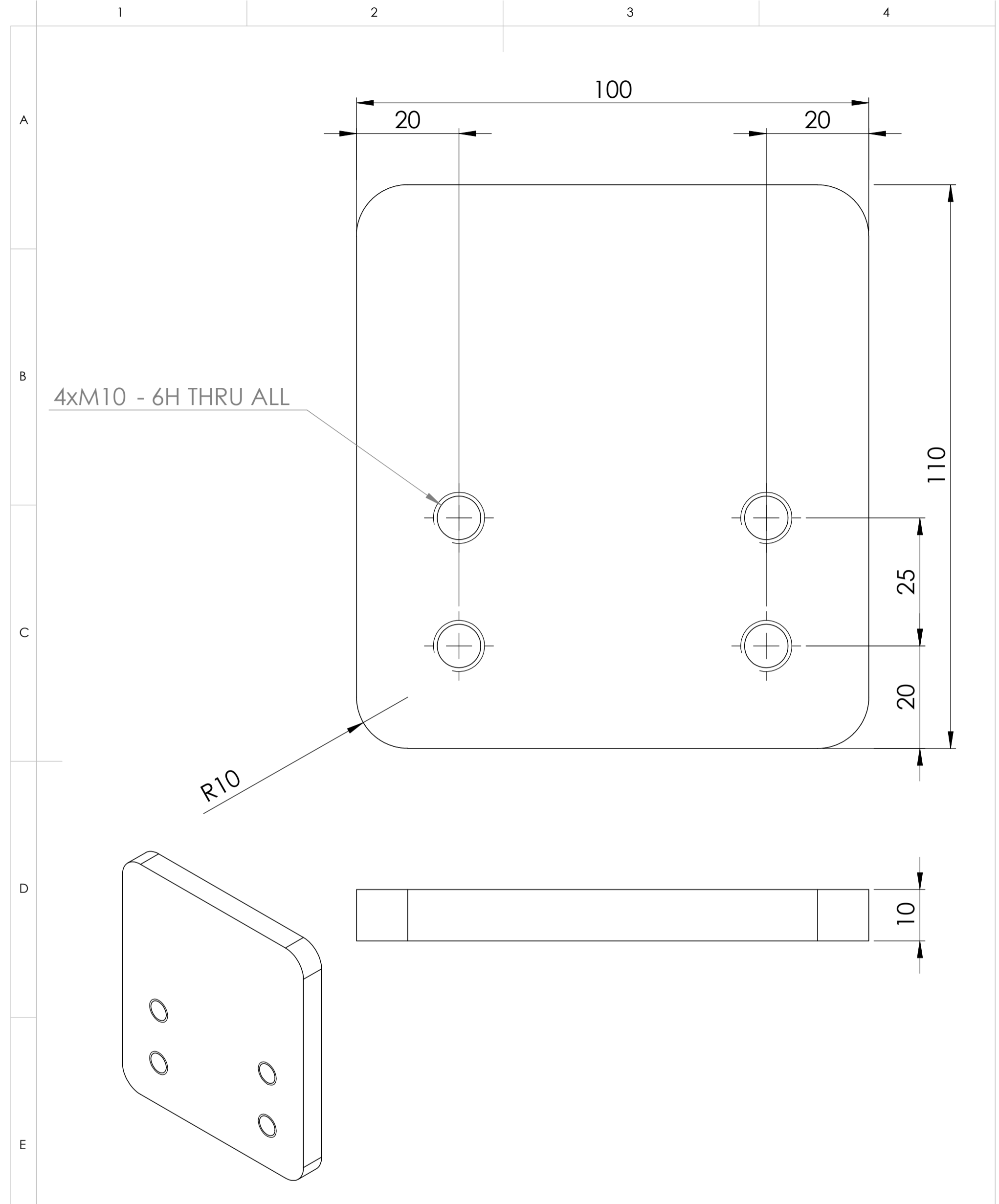

UNLESS OTHERWISE SPECIFIED: DIMENSIONS ARE IN MILLIMETERS SURFACE FINISH: TOLERANCES: LINEAR: ANGULAR:				FINISH:		DEBUR AND BREAK SHARP EDGES		DO NOT SCALE DRAWING		REVISION			
								TITLE: PLATNA 3					
DRAWN		NAME		SIGNATURE		DATE							
CHK'D													
APP'VD													
MFG													
Q.A						MATERIAL:		DWG NO.		A4			
						WEIGHT:		SCALE:1:1		SHEET 53 OF 61			

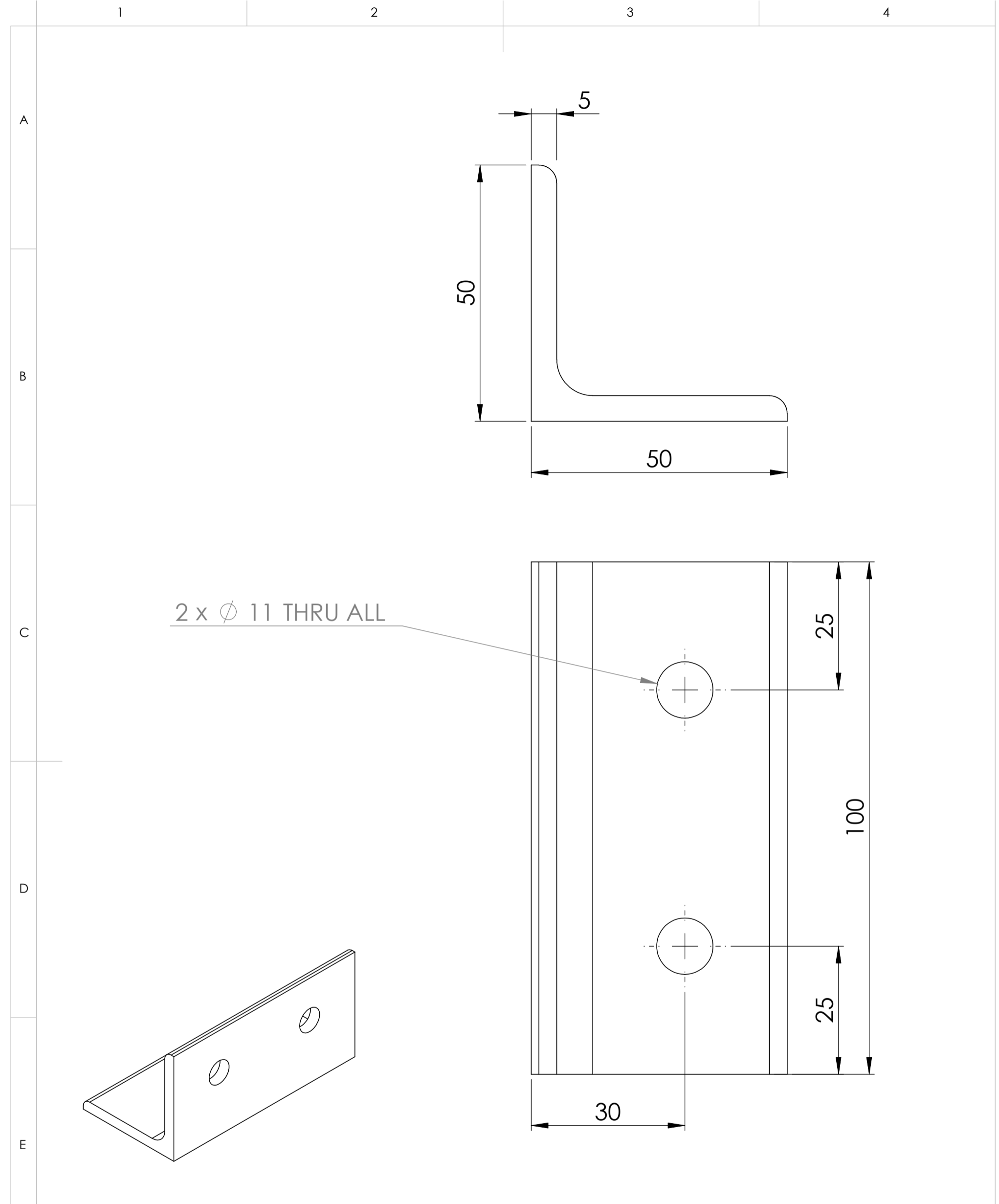

UNLESS OTHERWISE SPECIFIED: DIMENSIONS ARE IN MILLIMETERS SURFACE FINISH: TOLERANCES: LINEAR: ANGULAR:				FINISH:		DEBUR AND BREAK SHARP EDGES		DO NOT SCALE DRAWING		REVISION			
								<h1>L2</h1>					
DRAWN		NAME		SIGNATURE		DATE							
CHK'D													
APP'VD													
MFG													
Q.A						MATERIAL:		DWG NO.		A4			
								SAV 54					
						WEIGHT:		SCALE: 1:1		SHEET 54 OF 61			

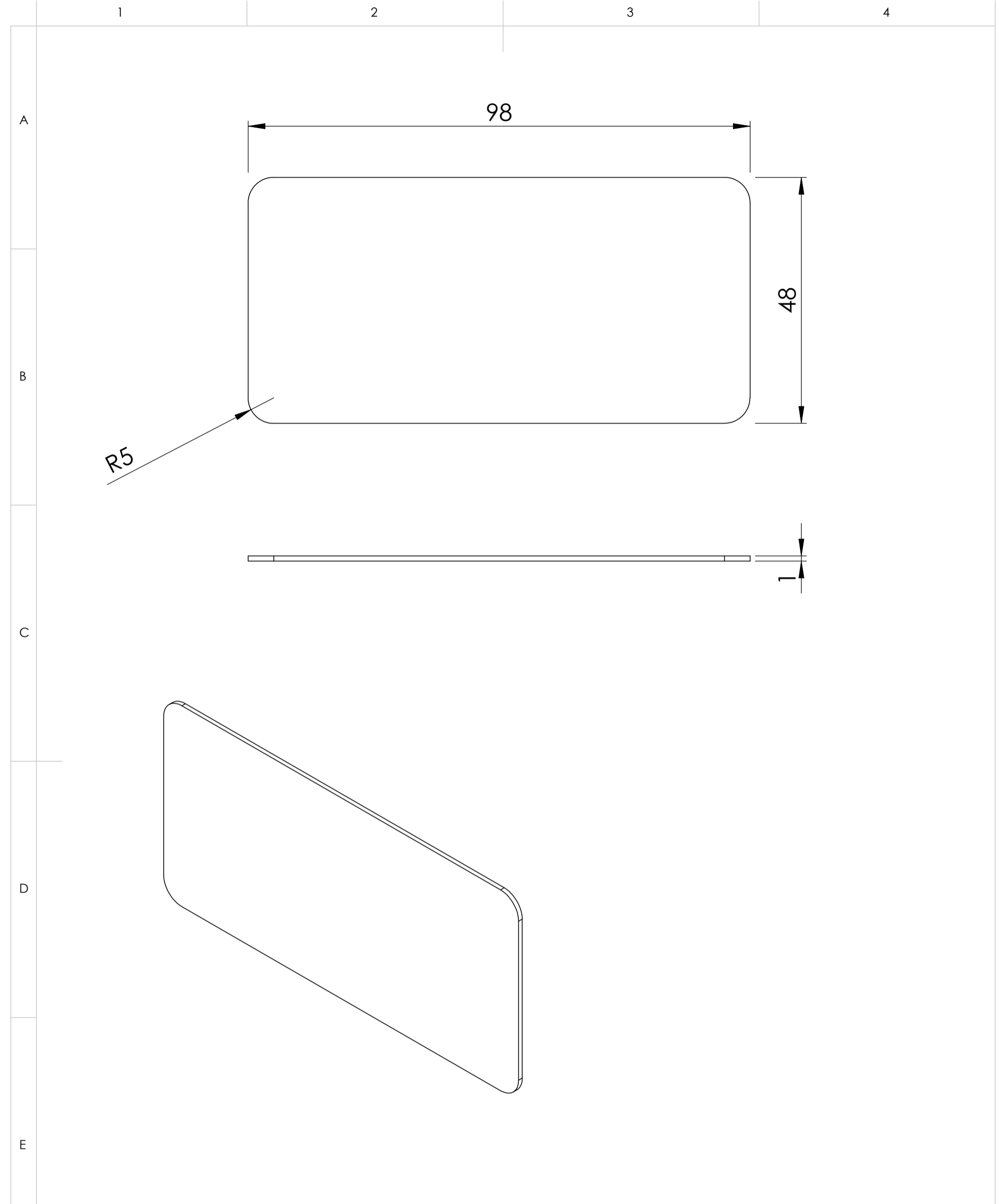

UNLESS OTHERWISE SPECIFIED: DIMENSIONS ARE IN MILLIMETERS SURFACE FINISH: TOLERANCES: LINEAR: ANGULAR:				FINISH:		DEBUR AND BREAK SHARP EDGES		DO NOT SCALE DRAWING		REVISION	
	NAME	SIGNATURE	DATE					TITLE: ZASLEPKA 2			
DRAWN	cas10r										
CHK'D											
APP'VD											
MFG											
Q.A				MATERIAL:			DWG NO.		SAV 55		A4
				WEIGHT:			SCALE:1:1		SHEET 55 OF 61		

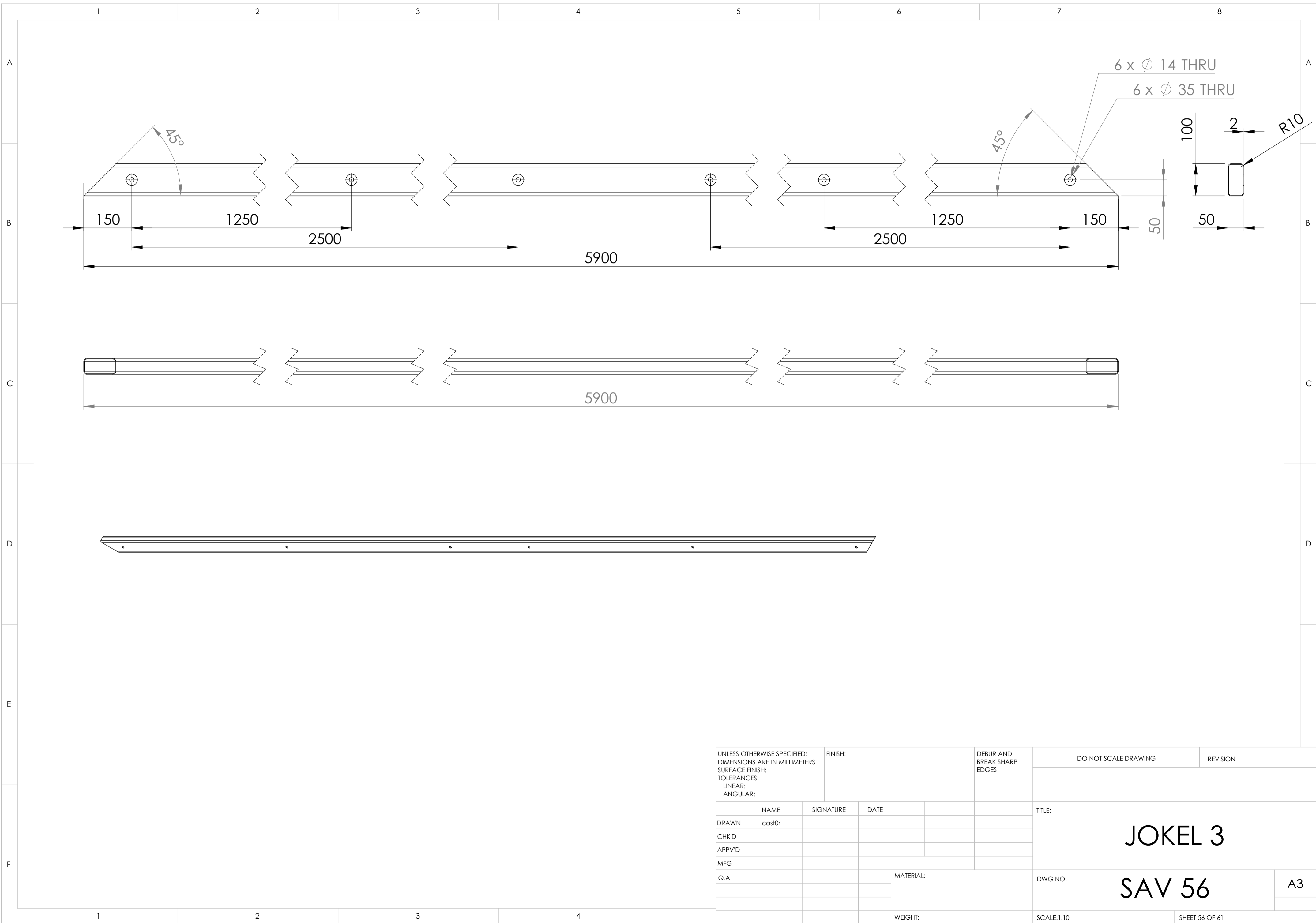

UNLESS OTHERWISE SPECIFIED: DIMENSIONS ARE IN MILLIMETERS SURFACE FINISH: TOLERANCES: LINEAR: ANGULAR:				FINISH:		DEBUR AND BREAK SHARP EDGES		DO NOT SCALE DRAWING		REVISION			
								<p style="text-align: center; font-size: 24pt; margin: 0;">JOKEL 3</p> <p style="text-align: center; font-size: 36pt; margin: 0;">SAV 56</p>					
DRAWN		NAME		SIGNATURE		DATE						TITLE:	
CHK'D													
APPV'D													
MFG													
Q.A				MATERIAL:				DWG NO.		A3			
				WEIGHT:				SCALE:1:10		SHEET 56 OF 61			

1 2 3 4 5 6 7 8

A
B
C
D
E
F

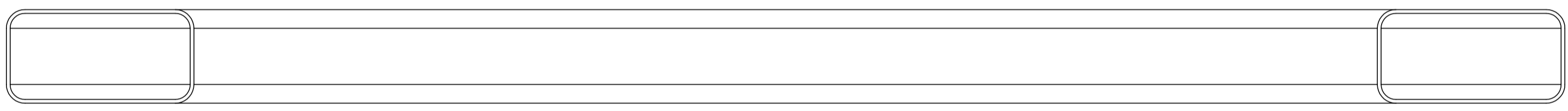
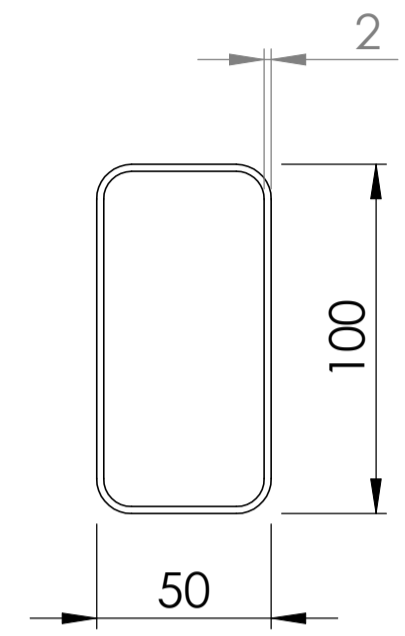
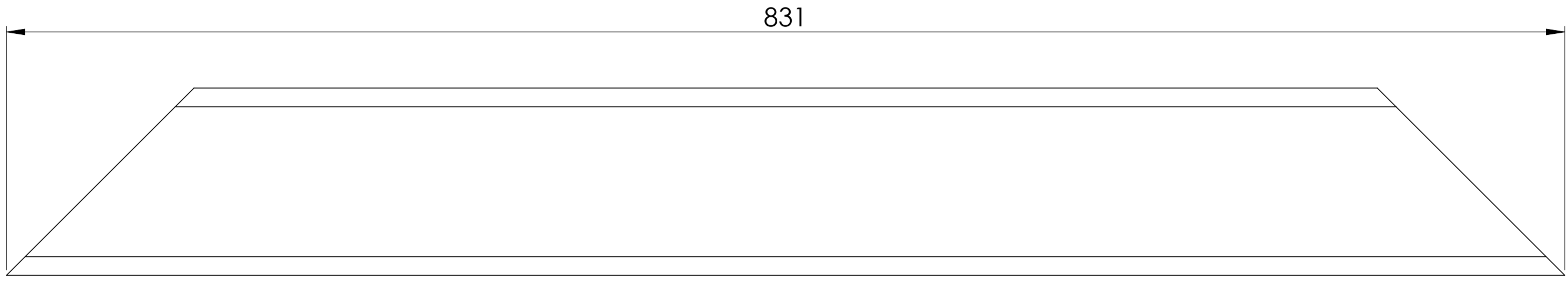

UNLESS OTHERWISE SPECIFIED: DIMENSIONS ARE IN MILLIMETERS SURFACE FINISH: TOLERANCES: LINEAR: ANGULAR:				FINISH:		DEBUR AND BREAK SHARP EDGES		DO NOT SCALE DRAWING		REVISION	
	NAME	SIGNATURE	DATE					TITLE: JOKEL 4			
DRAWN	cast0r							DWG NO. SAV 57			
CHK'D											
APPV'D											
MFG											
Q.A						MATERIAL:	SCALE:1:3		SHEET 57 OF 61		
						WEIGHT:			A3		

1 2 3 4

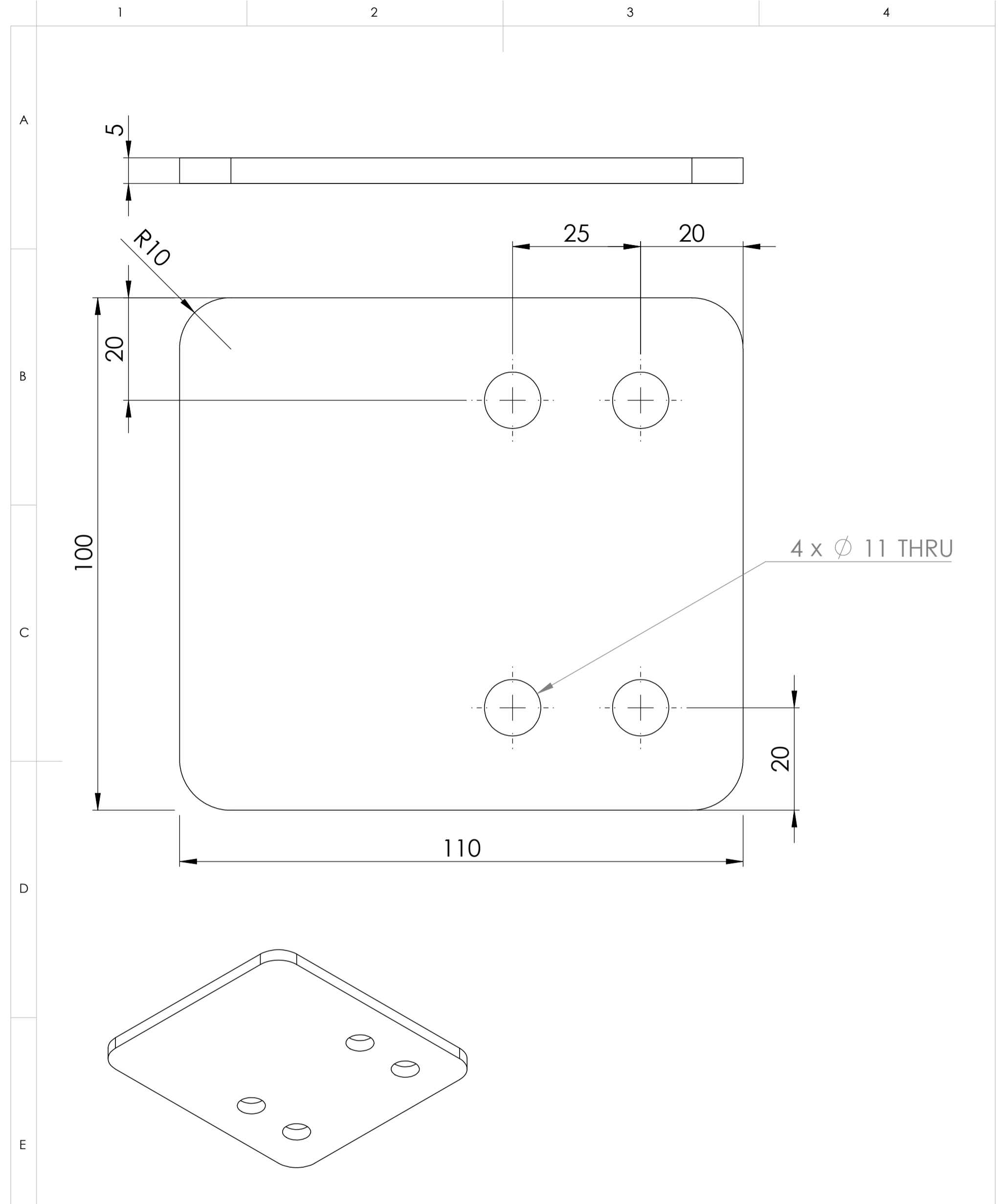

UNLESS OTHERWISE SPECIFIED: DIMENSIONS ARE IN MILLIMETERS SURFACE FINISH: TOLERANCES: LINEAR: ANGULAR:		FINISH:		DEBUR AND BREAK SHARP EDGES		DO NOT SCALE DRAWING		REVISION	
						TITLE: PLATNA 4			
DRAWN	NAME	SIGNATURE	DATE						
CHK'D									
APP'VD									
MFG									
Q.A				MATERIAL:		DWG NO.		A4	
				WEIGHT:		SCALE: 1:1		SHEET 58 OF 61	

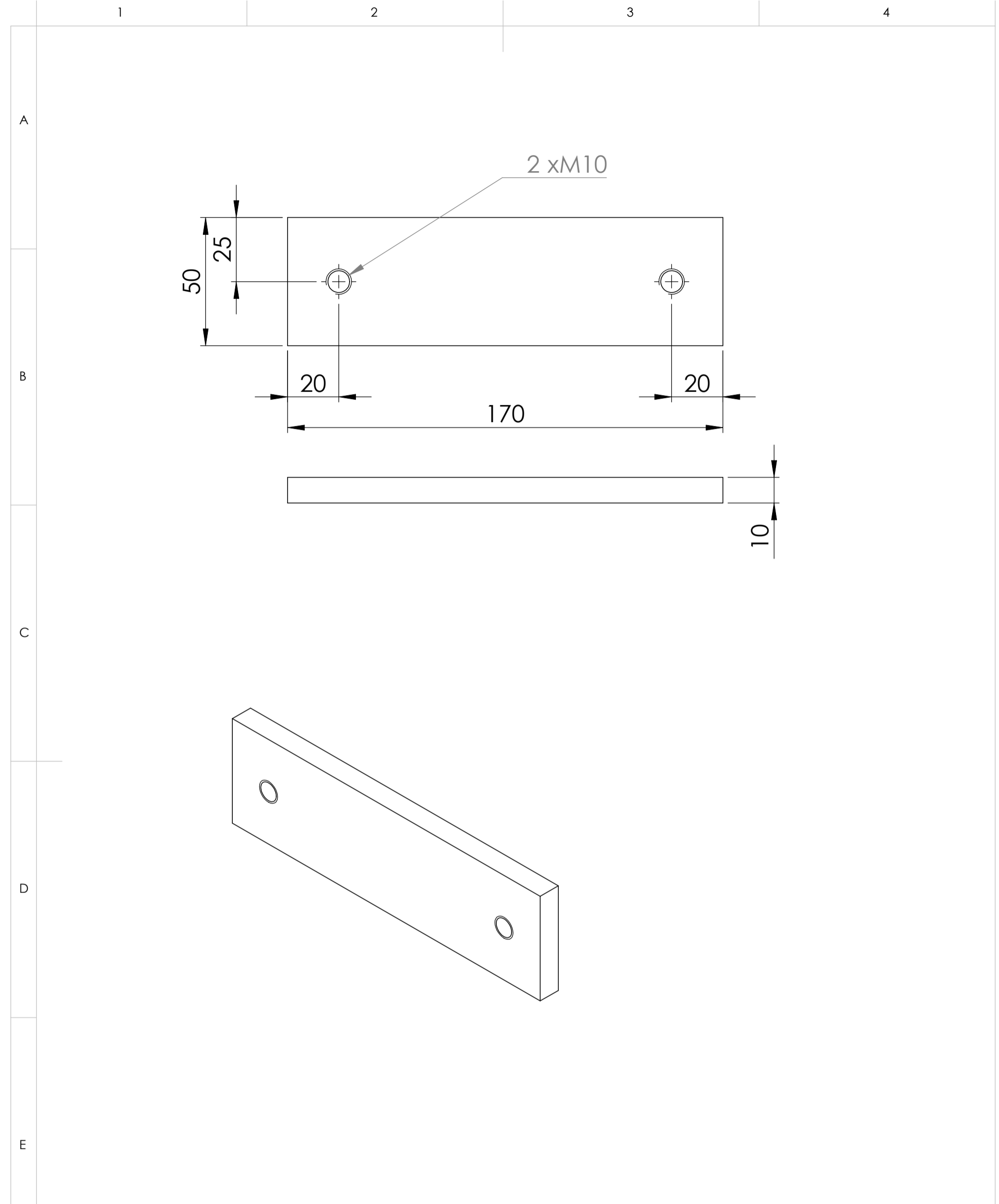

UNLESS OTHERWISE SPECIFIED: DIMENSIONS ARE IN MILLIMETERS SURFACE FINISH: TOLERANCES: LINEAR: ANGULAR:				FINISH:		DEBUR AND BREAK SHARP EDGES		DO NOT SCALE DRAWING		REVISION			
								<h1>PLATNA 8</h1> <h2>SAV 60</h2>					
DRAWN		NAME		SIGNATURE		DATE						TITLE:	
CHK'D													
APP'VD													
MFG								DWG NO.		A4			
Q.A						MATERIAL:		SCALE: 1:2		SHEET 60 OF 61			
						WEIGHT:							

	1	2	3	4
A				
B				
C				
D				
E				

UNLESS OTHERWISE SPECIFIED: DIMENSIONS ARE IN MILLIMETERS SURFACE FINISH: TOLERANCES: LINEAR: ANGULAR:		FINISH:		DEBUR AND BREAK SHARP EDGES		DO NOT SCALE DRAWING		REVISION		
	NAME	SIGNATURE	DATE			TITLE:				
DRAWN	cas10r									
CHK'D										
APP'VD										
F	MFG									
	Q.A			MATERIAL:		DWG NO.		dokumentacia		A4
				WEIGHT:		SCALE:1:1		SHEET 61 OF 61		