

No. ARTICLE	QTE	Description	LONGUEUR
1	1	40 x 40 x 3.0	2907.89
2	1	40 x 40 x 3.0	2610.87
3	1	platine ep 15	
4	1	40 x 40 x 3.0	1161.36
5	1	40 x 40 x 3.0	644.75
6	1	40 x 40 x 3.0	1398.85
7	1	platine ep 15	
8	1	platine ep 15	
9	1	platine ep 15	

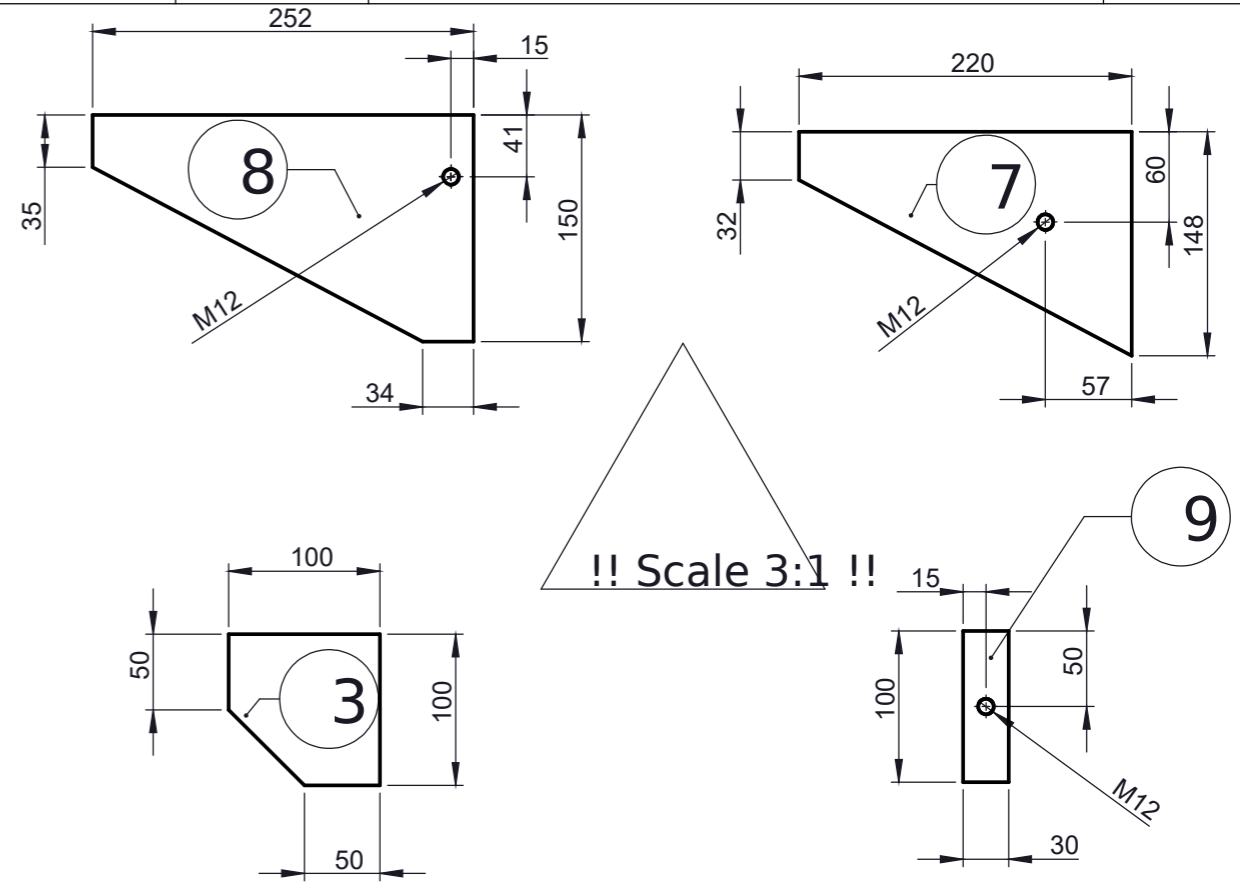

0			
Rev.	Draw date/Name/Signature	Check date/Name/Signature	Approval date/Name/Signature
Designation			
Customer :			
Form and general tolerance	Tolerance for welding construction	Scale 1:1	Material: matériau <non spécifié>
DIN ISO 2768	DIN ISO 13920-B	Size : A3	Weight 4.470 kg
Project CADRE AGRES DE LEVAGE			Surface treatment
Title :			Position number
			Drawing number-Rev.
			cadre agrès levage