

| | P (mm) | Qty | A (mm) | B (mm) | M (mm) | N (mm) | Hole_1 | Hole_2 | Hole_3 | Hole_4 |
|---------|---------|-----|--------|--------|--------|--------|--------|--------|--------|--------|
| WA-0303 | 277 | 4 | 375 | 375 | 330 | 330 | ∅ 15 | | ∅ 15 | |
| WA-0404 | 377 | 4 | 475 | 475 | 430 | 430 | ∅ 15 | | ∅ 15 | |
| WA-0505 | 477 | 4 | 575 | 575 | 530 | 530 | ∅ 15 | | ∅ 15 | |
| WA-0604 | 577/377 | 2/2 | 675 | 475 | 630 | 430 | ∅ 15 | ∅ 15 | ∅ 15 | ∅ 15 |
| WA-0606 | 577 | 4 | 675 | 675 | 630 | 630 | ∅ 15 | ∅ 15 | ∅ 15 | ∅ 15 |
| WA-0707 | 677 | 4 | 775 | 775 | 730 | 730 | ∅ 15 | ∅ 15 | ∅ 15 | ∅ 15 |
| WA-0808 | 777 | 4 | 875 | 875 | 830 | 830 | ∅ 15 | ∅ 15 | ∅ 15 | ∅ 15 |
| WA-1010 | 977 | 4 | 1075 | 1075 | 1030 | 1030 | ∅ 15 | ∅ 15 | ∅ 15 | ∅ 15 |

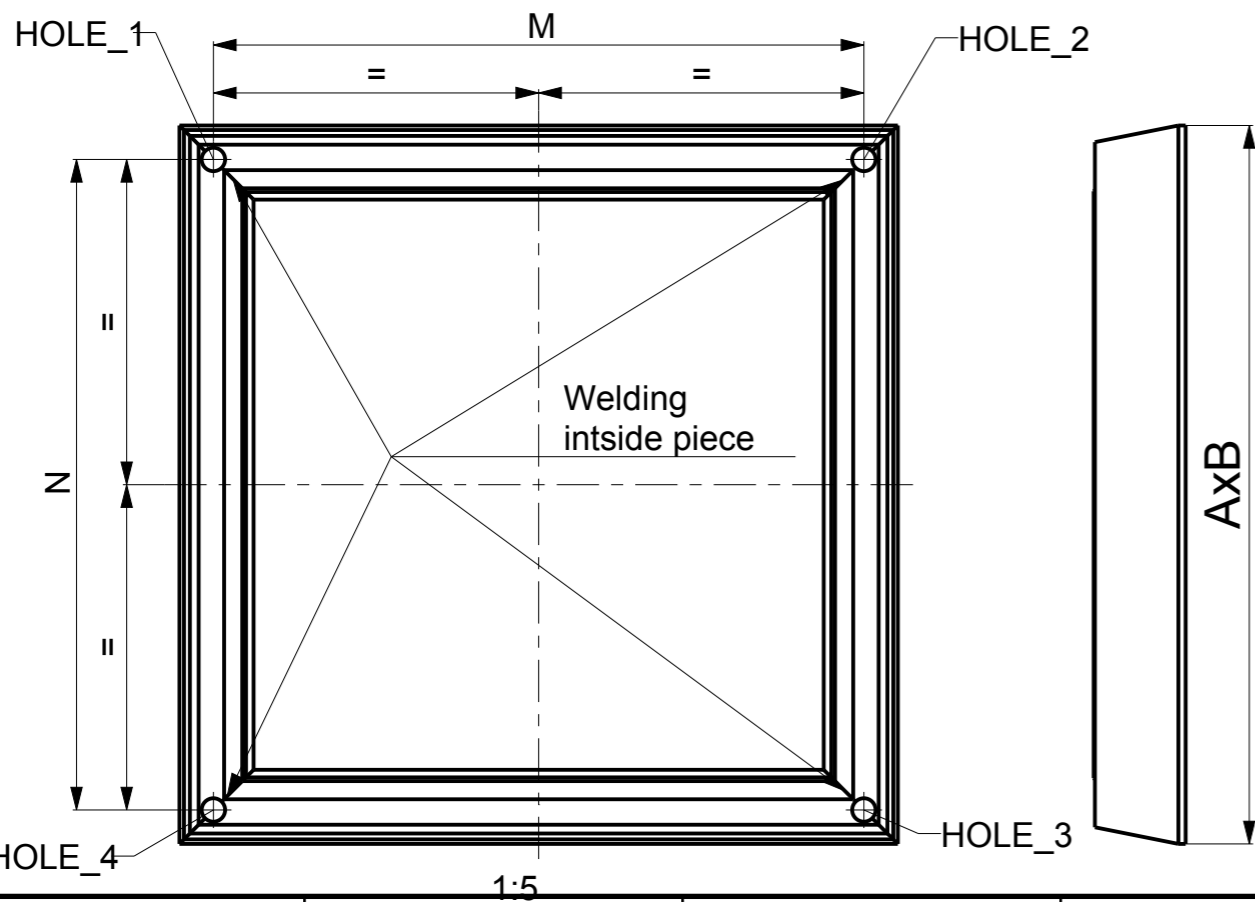
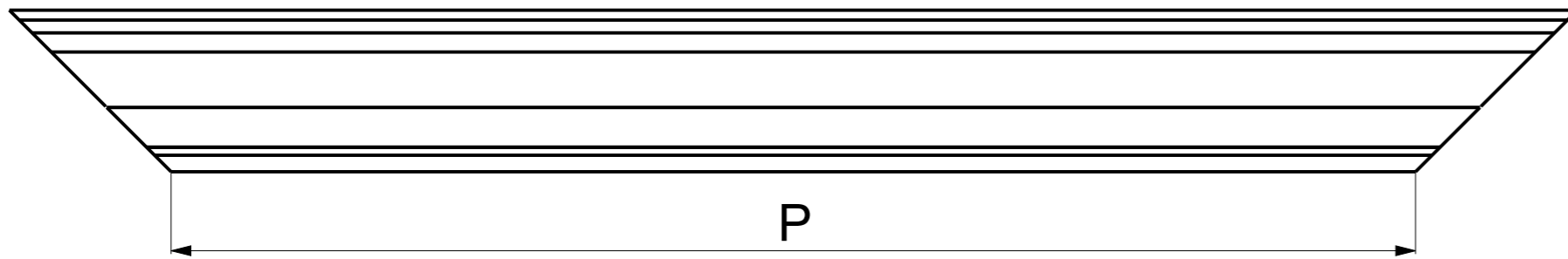

TOLERANCE LEVEL ± 0.5
ALL THE WELDING HAVE TO BE CLEANED

| Num. Appliance : | 700_60_ | Masse (kg) | 0,311 | Part | Material | Dimension | Norm | Drawing |
|------------------|---------|--|-------|------------------|-----------------------|------------|---------------|---------------|
| SIMOP SK s.r.o. | | Priemyselna 720 072 22 Strážske SLOVAKIA | | Name | Date | Revision : | A 24/09/13 | 1:1 |
| Format : A3 | | ISO 2768-mk | | Draw : | Baco | Aug-28-13 | Number part : | 700_60_071_04 |
| | | | | Verifi : | | | Sub-grup | |
| | | | | Name assembly: | REGARD-ALUMINIUM - WA | | | — ∅ — ⊕ — |
| | | | | Number Drawing : | 700_60_071 | | | Revision |
| | | | | | | | A | Sheet |
| | | | | | | | | 1/1 |