

Material :
Steel C35 E or AISI 1045

Heat treatment :
 Everywhere

Protection of surf :

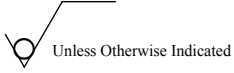

Casser les angles vifs / Remove sharp edges

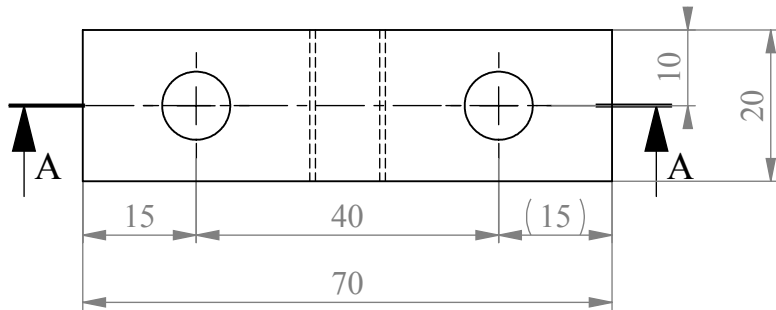
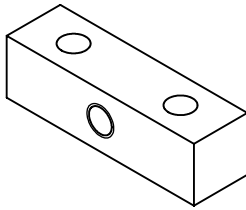
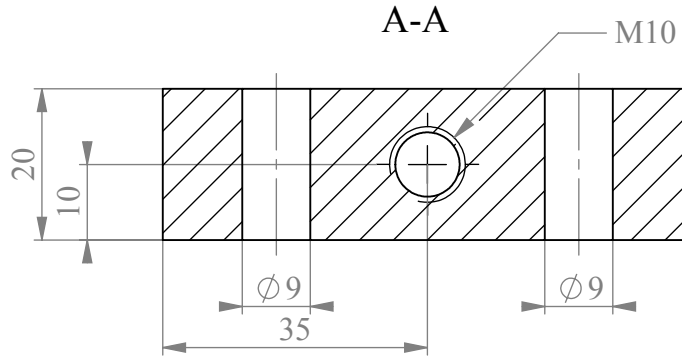

EXEPT OTHER INDICATION

General tolerances to be respected :
 ISO 2768 : m & k
 Welding : v
 Sheet Metal : v
 Mould : ISO 8062
 Surface texture : ISO 1302
 Welding Symbols : ISO 2553

WA +10

| - | 17/03/2016 | FX10394 | Creation du document |
|-----|------------|---------|----------------------|
| Mod | Date | By | Modifications |

Mass (Kg) :
0.191

Reference Number

**BLOC POUR VIS
 DE FREINAGE**

21637-00818-MPE

Rev :
-

Drawing Number

Toute copie imprimée de ce document n'est pas gérée
 Propriété exclusive de notre société. Reproduction
 ou utilisation interdite sans notre accord écrit.
 Any printed copy of this document is not managed
 Exclusive property of our company. Reproduction
 or prohibited use without our written agreement.

| | | |
|---------------------|-----------------|----------------------------|
| DTM Class : 2-01-07 | DTE Class : ... | D3 |
| Size : A4 | Scale : 1:1 | Units : mm SolidWorks 2012 |

Sheet :
1/1