

Material :  
**Steel C35 E or AISI 1045**

Heat treatment :  
 Everywhere  
 Protection of surf :

√3.2  
 Unless Otherwise Indicated

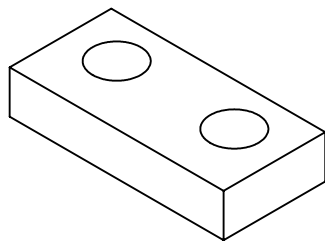
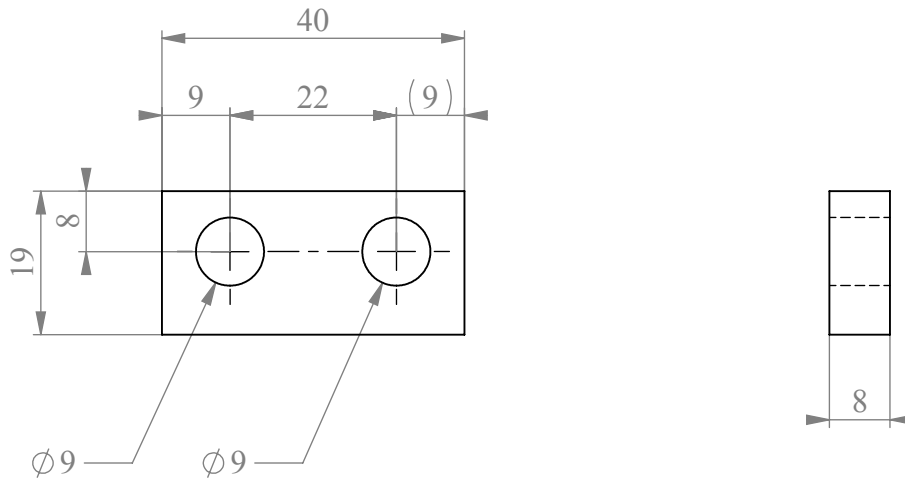

<b>EXEPT OTHER INDICATION</b> General tolerances to be respected : ISO 2768 : m & k Welding : v Sheet Metal : v Mould : ISO 8062 Surface texture : ISO 1302 Welding Symbols : ISO 2553	<b>WA +10</b>	-	17/03/2016	FX10394	Creation du document		
		Mod	Date	By	Modifications		
 <b>CAUTION :</b> All dimensions are in millimeters and projected view in ISO std					Reference Number	Mass (Kg) :	0.040
	<b>CALE</b> <b>COTE SORTIE BANDAGE</b>						
Toute copie imprimée de ce document n'est pas gérée Propriété exclusive de notre société. Reproduction ou utilisation interdite sans notre accord écrit. Any printed copy of this document is not managed Exclusive property of our company. Reproduction or prohibited use without our written agreement.					<b>21637-00812-MPE</b>	Rev :	-
					Drawing Number		
	DTM Class : 2-01-07	DTE Class : ...	D3		Sheet :		
Size : A4	Scale : 1:1	Units : mm	SolidWorks 2012	<b>1/1</b>			