

A

B

C

D

1

2

3

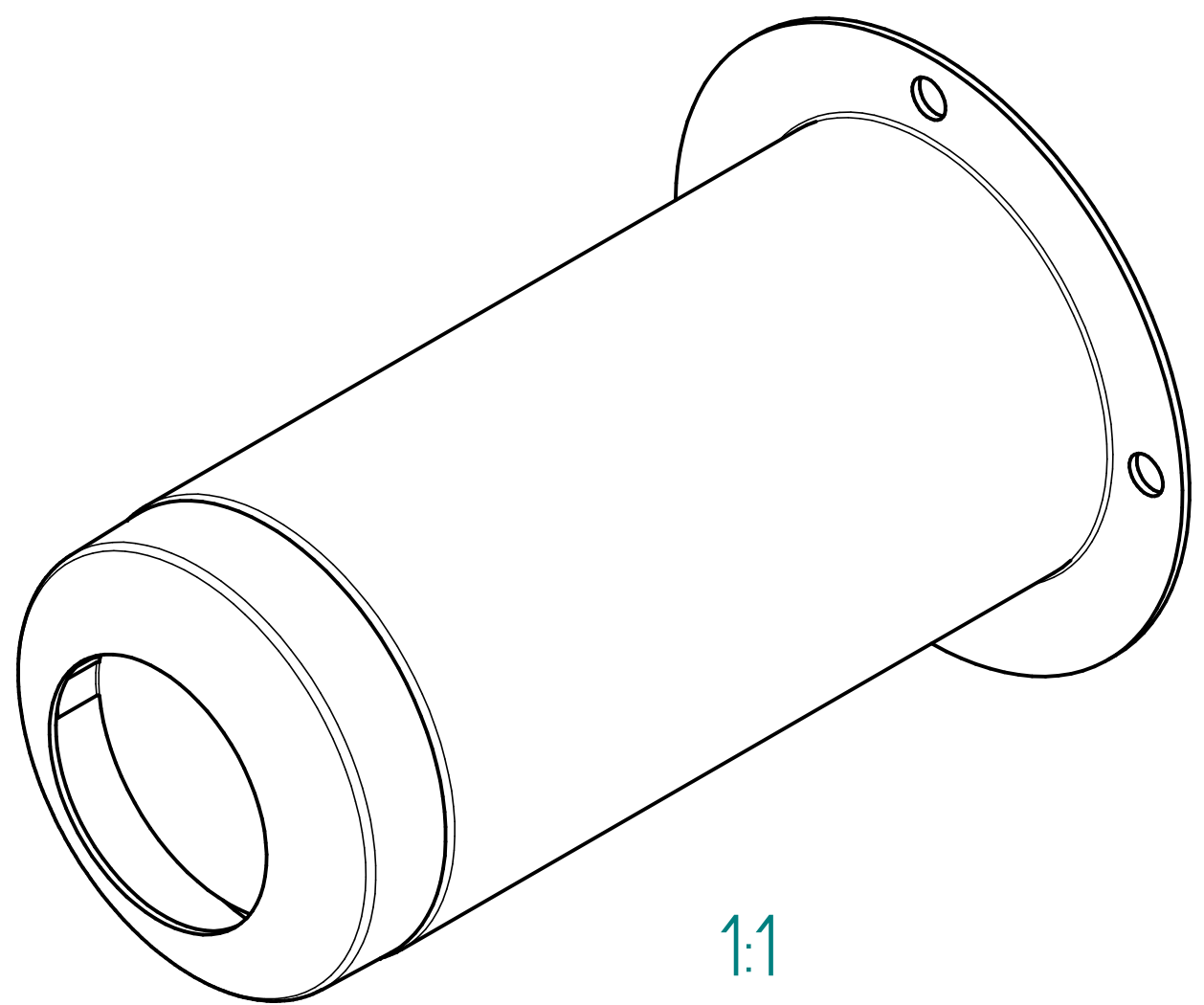
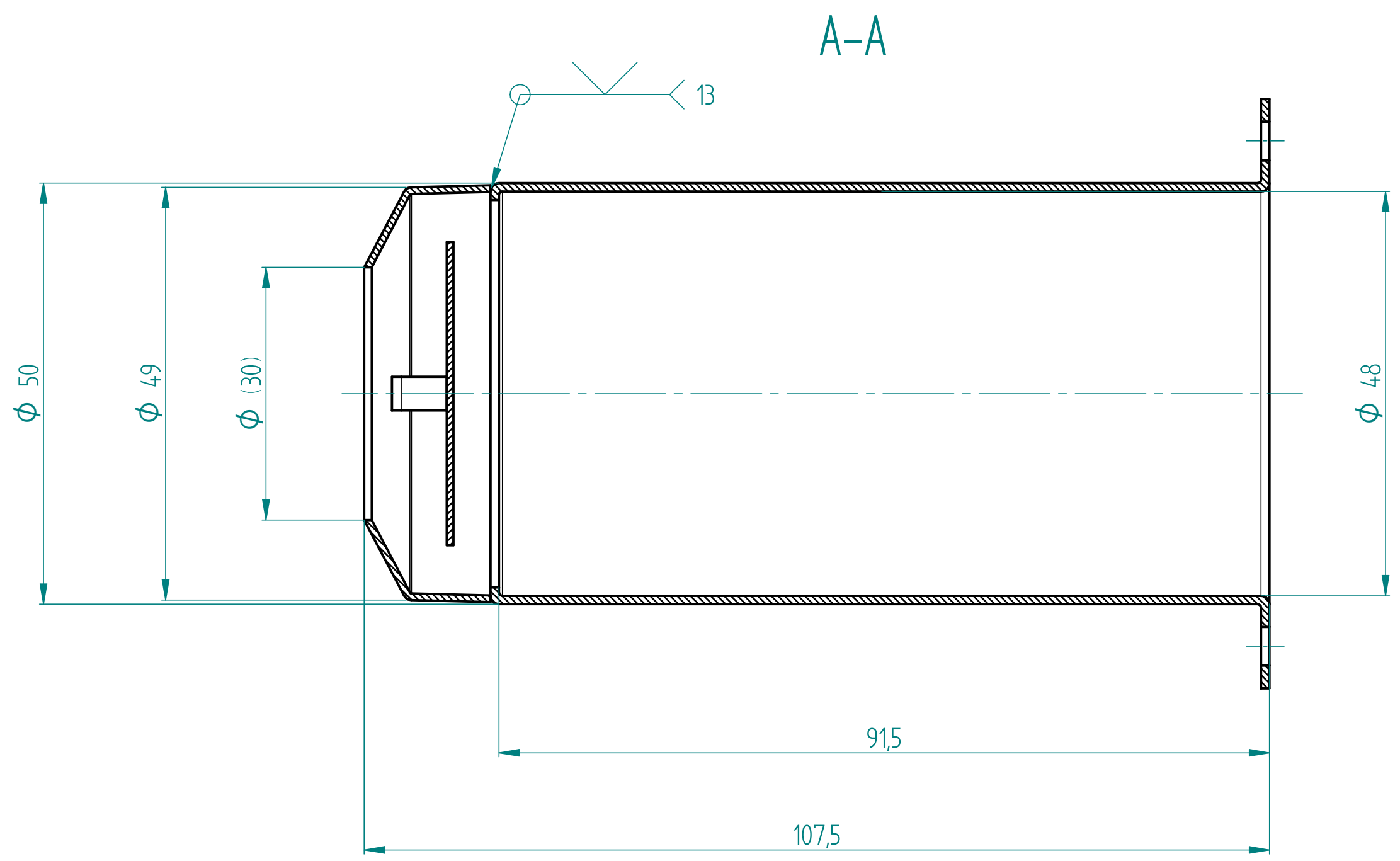
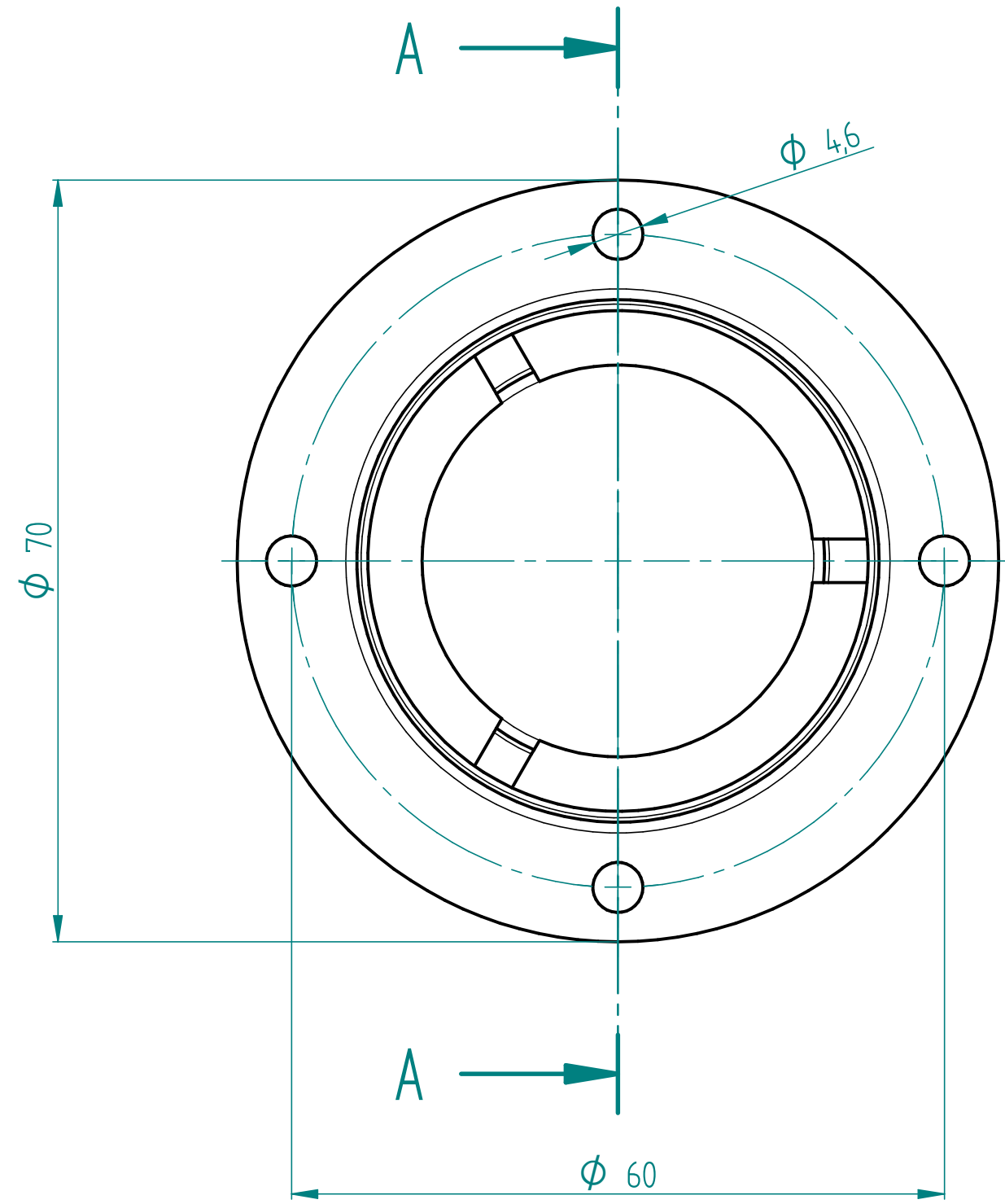

For Information only

General tolerances ISO 2768mK
 Surface treatment: Sand blasted
 Dimension check: Surrounded dimensions, form and position tolerance
 Surface finish: Free of burrs, sharp edges, scratches or poor workmanship
 A: check with limit gauge No.
 B: check with limit gauge No.

Material: 1.4301 - X5CrNi18-10				Volume:	
Date	Drawn by	Heater tube 1			Sheet
06.01.2005	fmu				1
Date	Checked by				of
			1	Revision	
		Format	Scale		Drawing number
		A3	1.25:1		