

完成個数を記入 ON THIS DRAWING ※改正記号ハ部品区分材料表ニヨル最新ノモノニヨルコト 補用対象部品ニハ「1」ヲ付与スル
 SEE THE PARTS LIST FOR THE LATEST DWG. NO. FILL '1' FOR SPARE PARTS

品番 ITEM NO.	部品管理 記号 ITEM MARK	※図面番号 DWG. NO.	※一式 分個数 QUANT.	名称 PART NAME	材質 MATERIAL	記事 REMARK	補用 C/M
		本図ニヨル THIS DWG	1	オイルピックアップ OIL PICK-UP	S1KM or S10-45C or 45F or S355J2C+C	JIS G 3445 or 4051 or EN10277-2	2

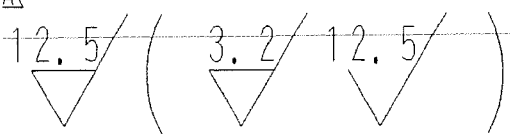

REVISED
 1:31 pm, Jan 05, 2010

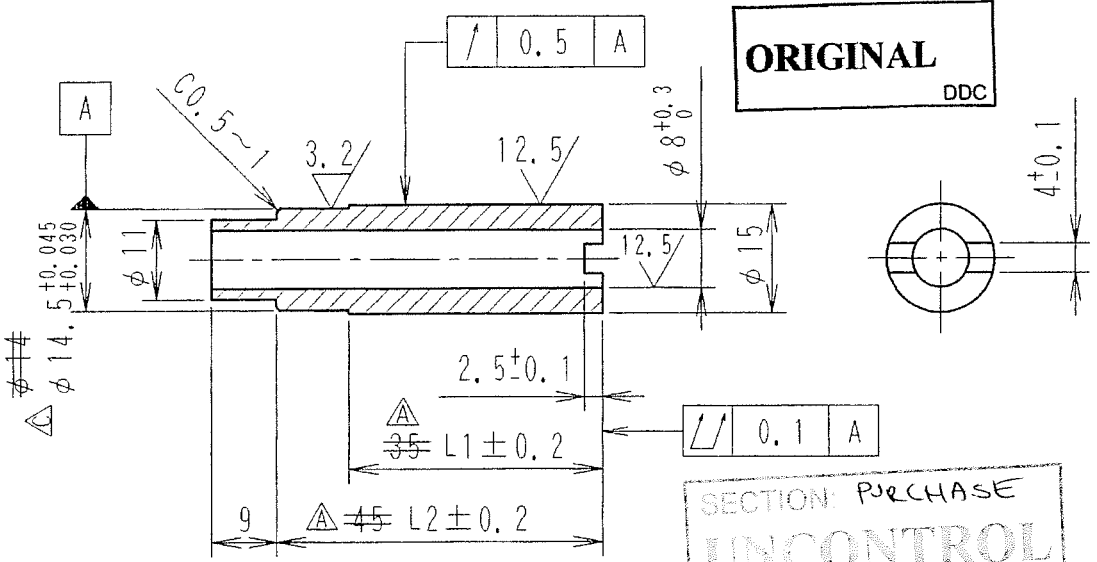

SECTION PURCHASE
 UNCONTROL
 DATE: 4.11.2014 DDC

- NOTES: 1. カエリ, 錆ナキコト。
 TO BE FREE FROM BURRS AND RUST.
 2. スケールナキコト (除去ハ酸洗ニヨルコト)。
 TO BE FREE FROM ANY SCALE (DESCALING SHALL BE BY PICKLING).
 3. 本部品ハ、指定化学物質ニ関スル購入品要素規格 ASB040004 ニ準拠スルコト。
 TO CONFORM TO ASB040004.

加工剤、洗浄剤、防錆剤、包装仕様選定表示 Specification selection and indication for processing agent, cleaning agent, rust inhibitor, packaging	
品ノ仕様、性質 Specification and characteristic of its	水分管理 Water content control
耐錆性 Rust resistance	必要 Need
形態 Form	必要 Need
その他 特記事項 Other special item	必要 Need
縮機組込前洗浄可否 Cleaning before assembling in compressor	可 Yes
縮機組込前洗浄工程ノ有無 Existence of cleaning process before assembling in compressor	有 With
加工剤、洗浄剤、防錆剤、包装仕様ノ選定ハ以下ニヨルコト The specifications of processing agent, cleaning agent, rust inhibitor and packaging shall be selected as follows. 社内加工: C-11-4006 In-house parts 社外加工: AS36C227 Purchasing parts	

部番 ITEM	部品管理 記号 ITEM MARK	L1	L2
1	⊕E△	35	45
2	⊕E△	74	84
3	⊕E△	60.6	70.6
4	⊕E△	50.6	60.6

For DDC
 For DCI

BR094408	09/11/20	城川	1								
材質追加 ADD MATERIAL	藤井	部番 ITEM	塗装箇所 PLACE	塗装種別 PAINT	素地 FOUND	工程 PROCESS	仕上色 COLOR	艶 GLOSS	塗装(マタハ備考) REMARK		
BR091545	09/07/09	吉田(健)	指示ナキ箇所ノ公差 TOLERANCE NOT INDICATED			JT100G-VD					
部番4及ビ注記3追加 ADD ITEM-4 AND NOTE 3	松川	松川	作図沿革 DESIGNED ORIGIN			オイルピックアップ					
承認 APPROVED	照査 CHECKED	設計 DESIGNED	製 DRAWN	ダイキン工業株式会社 DAIKIN INDUSTRIES LTD	尺度 SCALE	OIL PICK-UP					
				作成日 DATE	03.07.07	試作 TRIAL PRODUCTION	4PT00033E				
				部品コード PART CODE	JC1,21840						