

A-A (2 : 1)

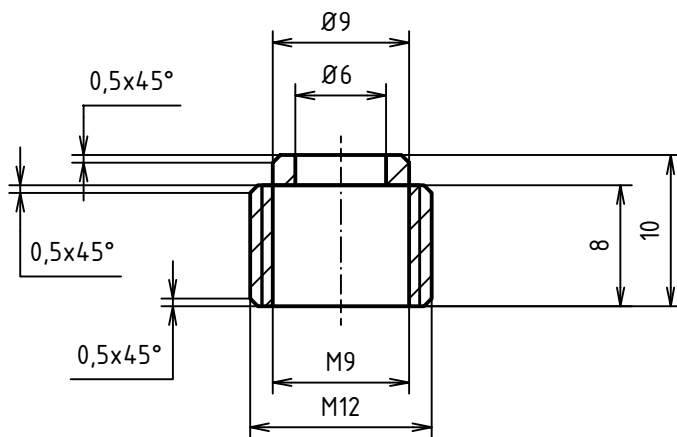

B-B (2 : 1)

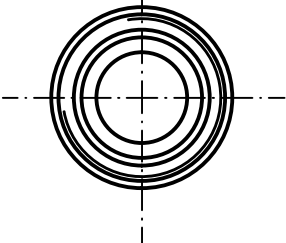
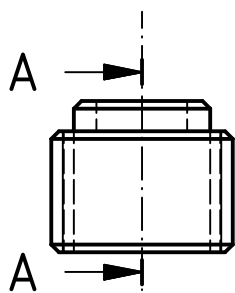
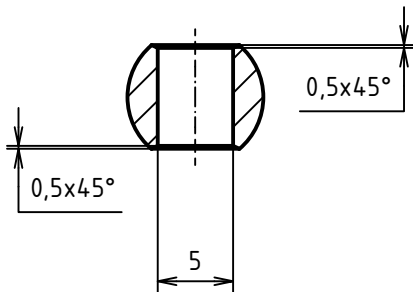
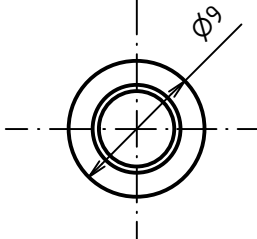
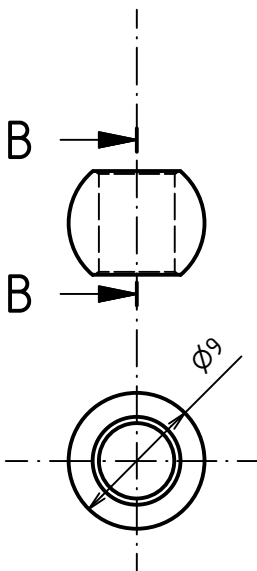

Ra 3,2 (✓)

Formát A4	Metóda premietania 	Mierka 2:1	Hmotnosť	Polovýrobok KR14-12	Materiál 17 040	Všeobecné tolerancie ISO 2768-mK	
Zodpovedné oddelenie		Technický referent		Vyhotovil RScott	Schválil	Dátum schválenia	
				Stav dokumentu KONTROLUJE SA		Typ dokumentu Výrobný výkres	
				Titul; doplnkový titul Protikus+Gul'ka		Číslo výkresu 02-02	
				(dýza 2)		Zmena	Dátum vydania 30.09.2015