

A-A (2 : 1)

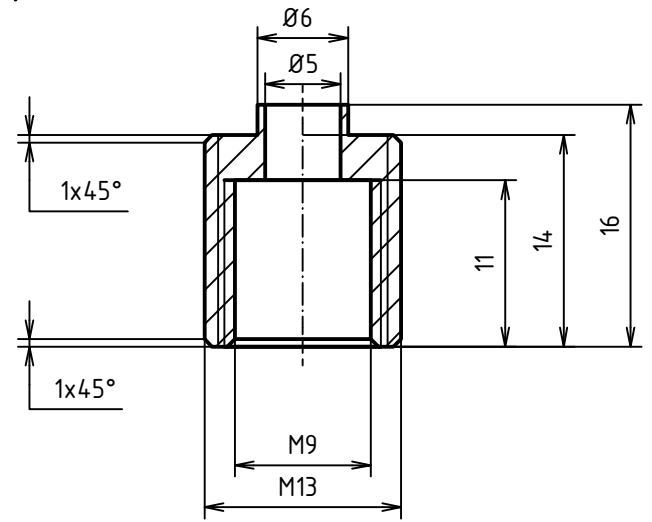

B-B (2 : 1)

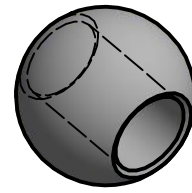
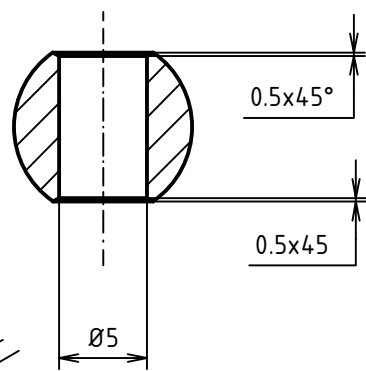
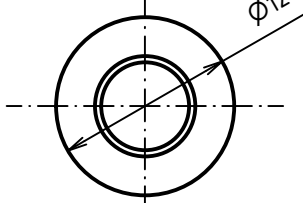
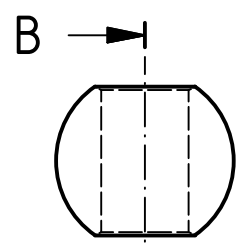

$\sqrt{Ra\ 3,2}$ (✓)

Formát A4	Metóda premietania 	Mierka 2:1	Hmotnosť	Polovýrobok KR13-20	Materiál 17 040	Všeobecné tolerancie ISO 2768-mK	
Zodpovedné oddelenie		Technický referent		Vyhotovil RScott	Schválil	Dátum schválenia	
				Stav dokumentu KONTROLUJE SA		Typ dokumentu Výrobný výkres	
				Titul; doplnkový titul Gul'ka+protikus (dýza 1)		Číslo výkresu 01-02	
				Zmena	Dátum vydania 30.09.2015	Jazyk SK	List 1