

KROV - VÝKAZ PRVKOV						
MATERIÁL	PRIEREZ (mm)	DĹŽKA (m)	POČET (ks)	CELKOVÁ DĹŽKA (m)	OBJEM (m³)	CELKOVÝ OBJEM (m³)
KLEŠTINY						
K1	60 / 180	5.33	44	234,52	0,0576	2.533
K12	60 / 180	2.60	2	5,20	0,0281	0.562
CELKOM: KLEŠTINY						2.589
KROKVA						
K1	100 / 160	5.61	34	190,74	0.0897	3.0520
K2	100 / 160	3.82	7	26,74	0.0611	0.4280
K3	100 / 160	2,75	2	5,50	0.0440	0.0880
K4	100 / 160	5,52	2	11,04	0.0883	0,1770
K5	100 / 160	3,70	2	7,40	0,0592	0,1184
K6	100 / 160	2,10	1	2,10	0.0336	0,0336
K7	100 / 160	1,19	2	2,38	0,0191	0,0381
K8	100 / 160	1,96	2	3,92	0,0314	0,0627
CELKOM: KROKVA						3,9980
STĹPIK						
S1	160/160	2,60	2	5,20	0,0665	0,1332
CELKOM: STĹPIK						0,1332
VÁZNICA						
V1	160 / 160	9,10	1	9,10	0.2330	0.2330
V2	160 / 160	3,96	1	3,96	0.1020	0.1020
V3	160 / 160	3,12	1	3,12	0.0800	0.0800
V4	160 / 160	21,50	1	21,50	0.5504	0.5504
CELKOM: VÁZNICA 160/160						0,9560
V4	160 / 200	21,50	2	43,00	0.6880	1,3760
CELKOM: VÁZNICA 160/220						43,00
CELKOM: VÁZNICA						2,3320
PÁSIK						
P	100/100	0,95	4	3,80	0.0095	0.0380
CELKOM: PÁSIK						0.0380
ÚŽĽABNÁ KROKVA						
UK	160/160	4,35	2	8,70	0.1114	0.2227
CELKOM: PÁSIK						0.2227
LATOVANIE POD ŠKRIDLU (osovo po 350 mm) (PLOCHA STRECHY 200,0 m²)						
60 / 40	36,54 m²				1,4616	
CELKOM: LATOVANIE						1,4616
KONTRALATOVANIE						
60 / 40	5.61	34	190,74	0.0135	0.4578	
60 / 40	3.82	7	26,74	0.0092	0.0642	
60 / 40	2,75	2	5,50	0.0066	0.0132	
60 / 40	5,52	2	11,04	0.0132	0,0265	
60 / 40	3,70	2	7,40	0,0089	0,0178	
60 / 40	2,10	1	2,10	0.0050	0,0050	
60 / 40	1,19	2	2,38	0,0029	0,0057	
60 / 40	1,96	2	3,92	0,0047	0,0094	
CELKOM: KONTRALATOVANIE						0,5996
KROV CELKOM						11,374 m³

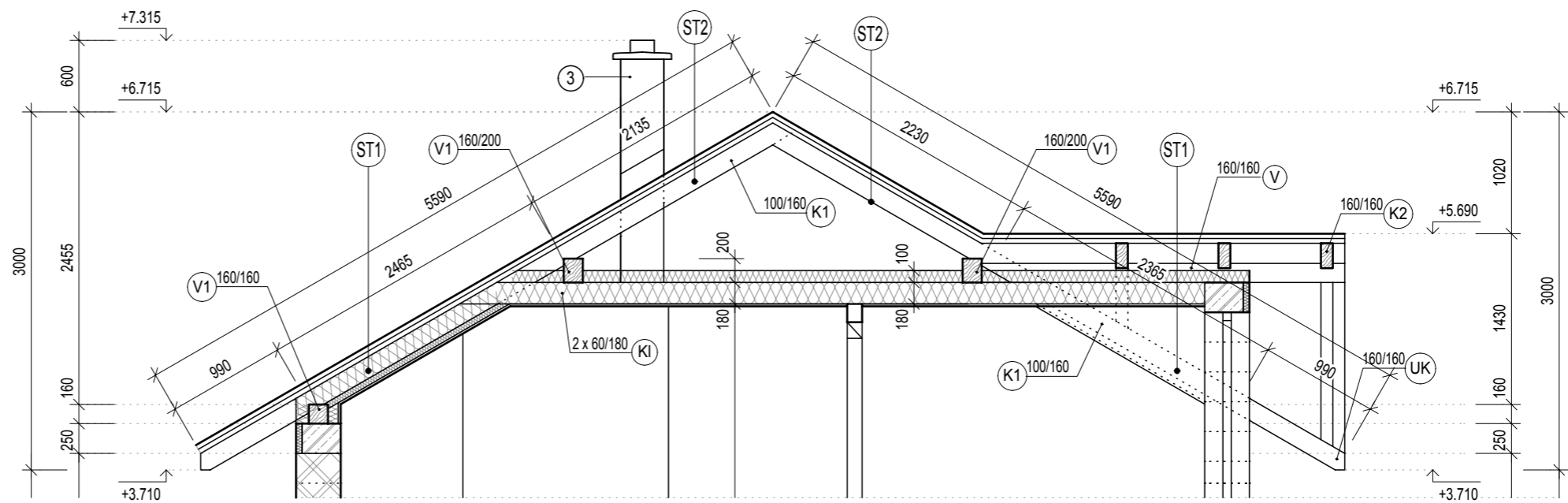

LEGENDA MATERIÁLOV

- MURIVO Z POROBETÓNOVÝCH TVÁRNIC YTONG LAMBDA P4-500
ROZMERY: 375 x 249 x 499 mm
- MURIVO Z POROBETÓNOVÝCH TVÁRNIC YTONG P4-500
ROZMERY: 300 x 249 x 499 mm
- MURIVO Z POROBETÓNOVÝCH TVÁRNIC YTONG P4-500
ROZMERY: 125 x 249 x 599 mm
- ZATEPLENIE ČELA ŽELEZOBETÓNOVEJ DOSKY:
EXTRUDOVANÝ POLYSTYRÉN STYRODUR C 3050 HRÚBKY 50 mm
- DREVO
- ŽELEZOBETÓN

VYSVETLIVKY

- ③ KOMÍN SCHIEDEL UNI PLUS Ø 180 mm

AXONOMETRIA KROVU

