

1 2 3 4 5 6

A

B

C

D

A

B

C

D

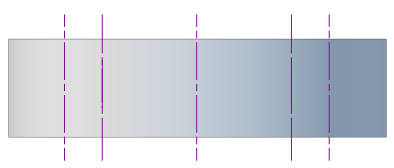
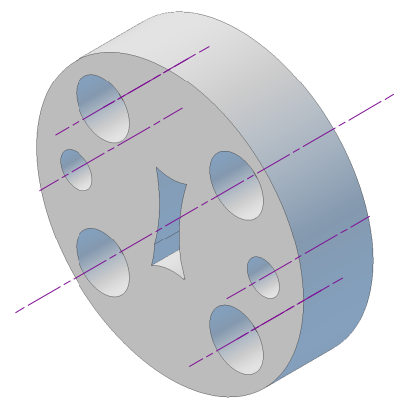
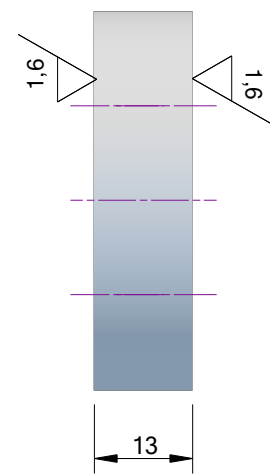
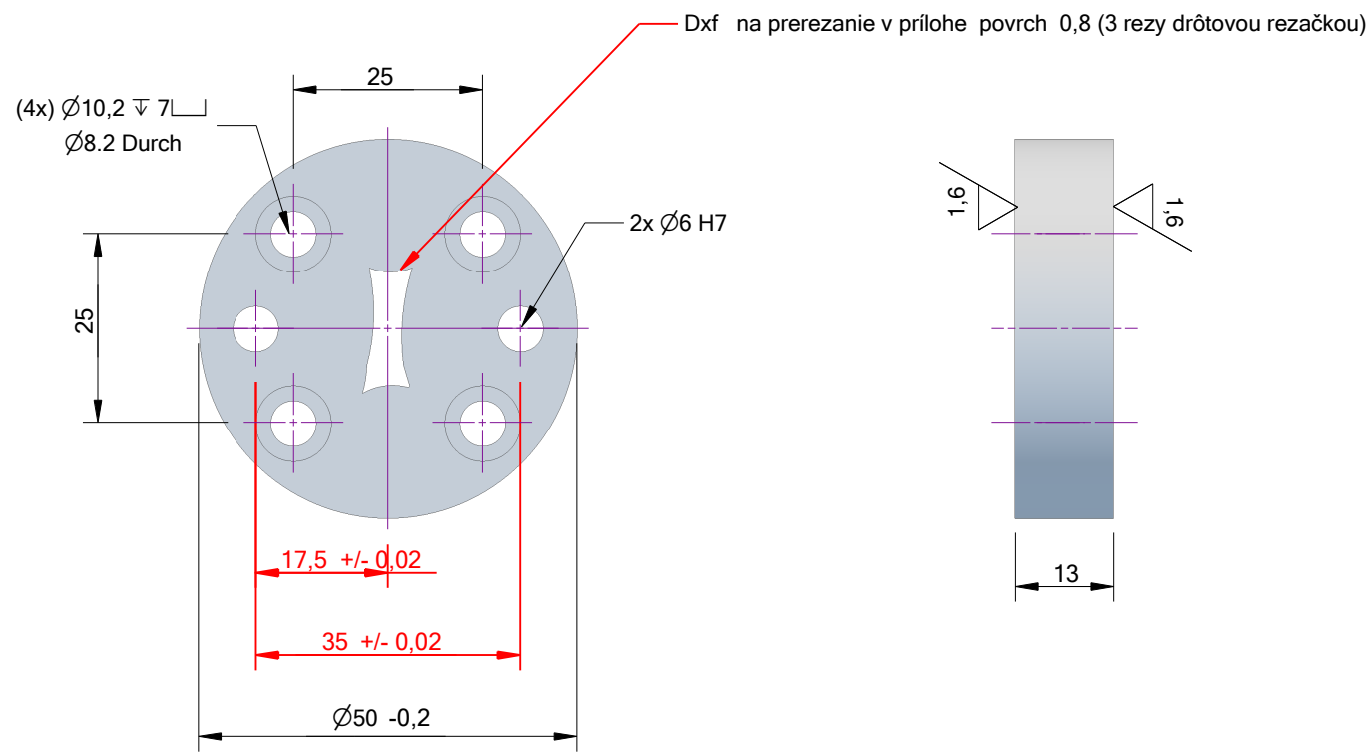

		Roffelsen PLASTICS			
Name Koncové S2019092			Material 1.4301		
Treatment -----		Date 23.09.2019	Quantity 1x	Scale 1:1	

1 2 3 4 5 6