

Freibereich ohne Gewinde  
in vollem Querschnitt  
NO THREAD ON FULL 360°

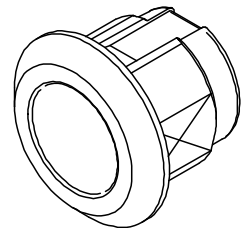
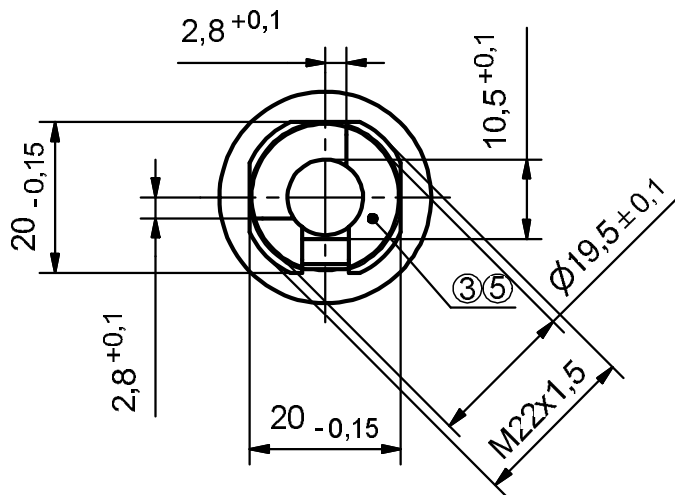

( ) = Prüfmaß / DIMENSION TO BE CHECKED

VISIBLE SURFACE ———  
NO MARKS OF EJECTOR PINS  
OR SPRUE IN THIS AREA  
LETTERS TO: DIN 30640  
LETTERS SIZE 2 mm RAISED  
0,2 mm RECESSED

IDENTIFICATIONS  
① Logo  
② MATERIAL INDICATION  
③ CAVITY INDICATION  
④ DATE-STAMP  
⑤ SUPPLIER IDENT.  
TO DN 052-01  
Valid only for new tools

Maße ohne Toleranzangabe DIMENSIONS WITHOUT TOLERANCES DIN 1687-4 GTA 12		Werkstoff/MATERIAL ZL 0410 EN 1774			
		Oberfläche SURFACE roh (unbearbeitet) / UNTREATED			
		Gewicht/WEIGHT 27,33 g ± 5%		VOLUME 4042,86 mm <sup>3</sup>	
		Farbe/COLOR RAL			
Benennung		TITLE		Artikelnummer ITEM NO.	
				<b>.00-</b>	
		PROJECT NO.:		3658-A-13 VI	