

A-A

1620

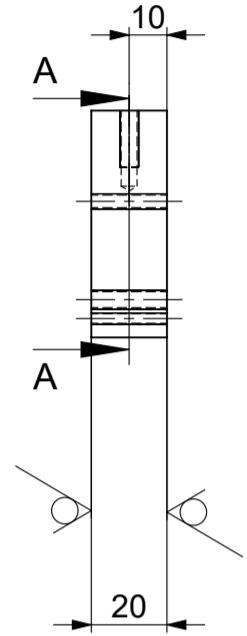

1:5

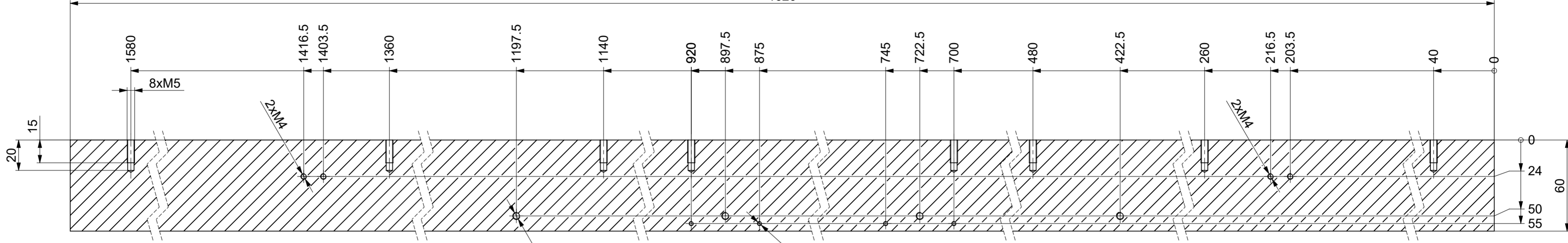
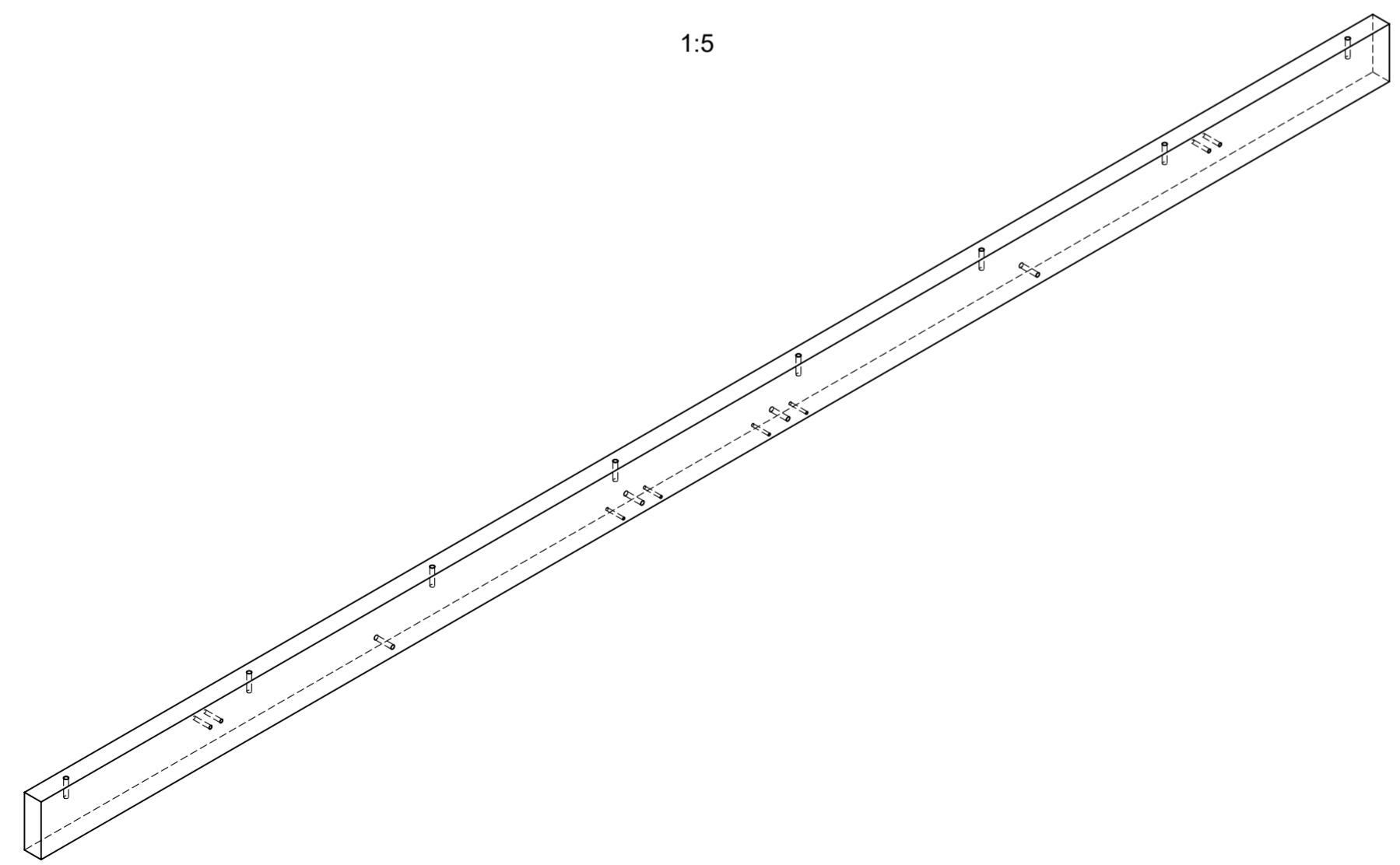

-Alle Koordinatenmasse +/-0.2mm  
 -All coordinates mass +/-0.2mm

-Masshaltig schwarz eloxiert  
 -Dimensional accuracy black anodized

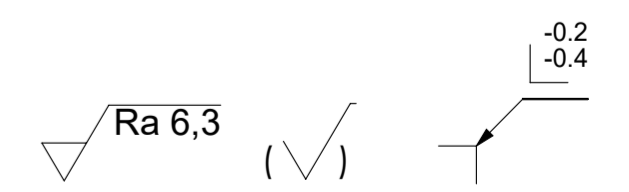

<small>Copyright © by encom GmbH          Schutzvermerk ISO 18016          Copying of this document, and giving it to others and the use or communication of the contents thereof, are forbidden without express authority. Offenders are liable to the payment of damages. All rights are reserved in the event of the grant of a patent or the registration of a utility model or design.</small>	Material	Al Mg Si 1	Erstellt	08.02.2017	S.Baumann		Allgemeintoleranzen ISO 2768-mK			
	Material-Nr.	3.2315	Geändert	13.02.2020	D.Triponez		Blatt	1 / 1	M 1:2	A2
			Geprüft			Ursprung	Z010308	Zeichnungs-Nr. <b>Z022581</b>		Index <b>03</b>
	Benennung / Beschreibung <b>Strebe</b>		FREIGEgeben							