

No. ARTICLE	QTE	DESCRIPTION
1	1	
2	3	
3	1	
4	1	
5	1	
6	1	
7	1	

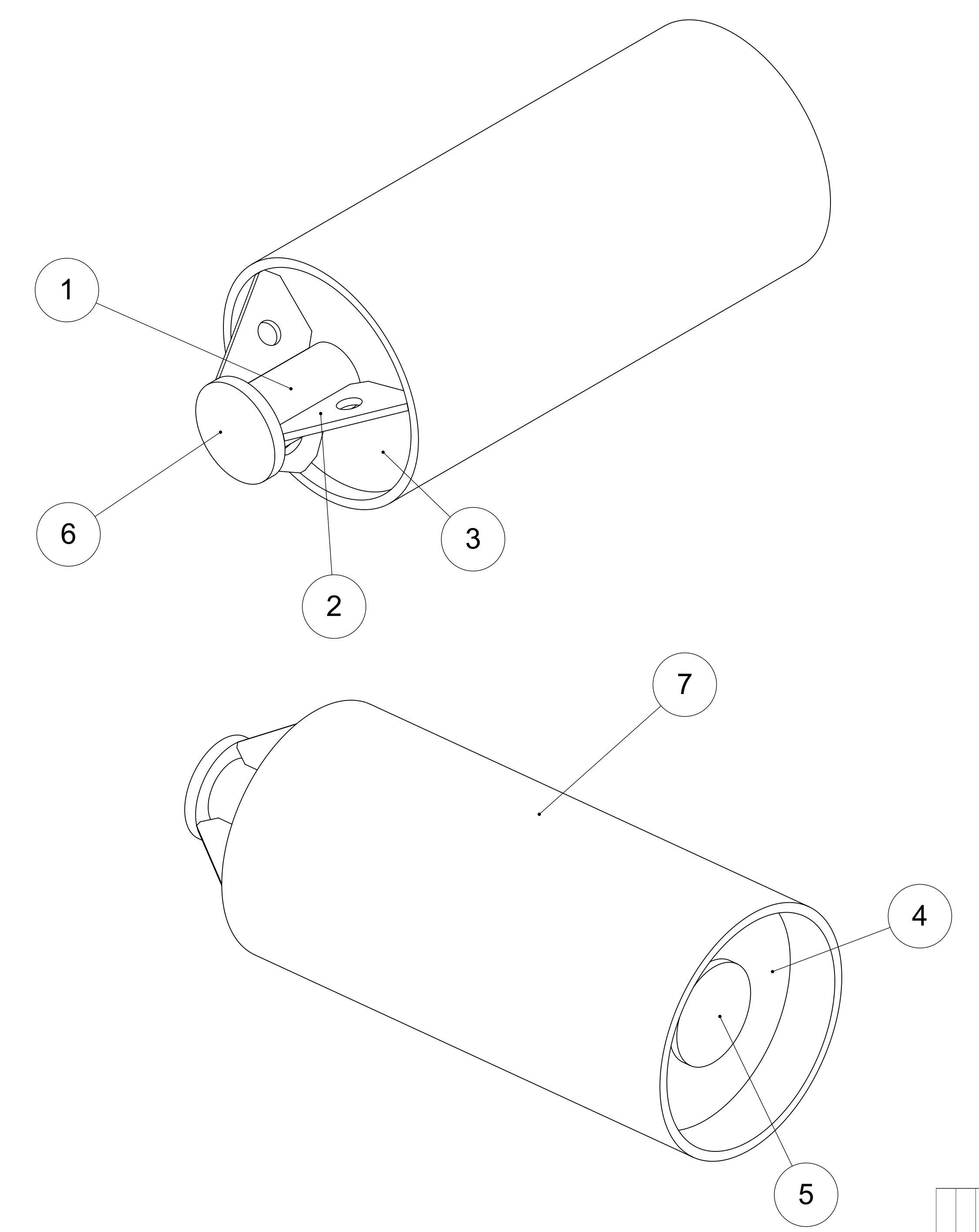

NOTA: FACES USINEES NON PEINTES

PEINTURE  
 EPOXYE D'ARRÊT - LACRE POLYURETHANE  
 SATINEE - SANS PBRONGES  
 ET USINAGES

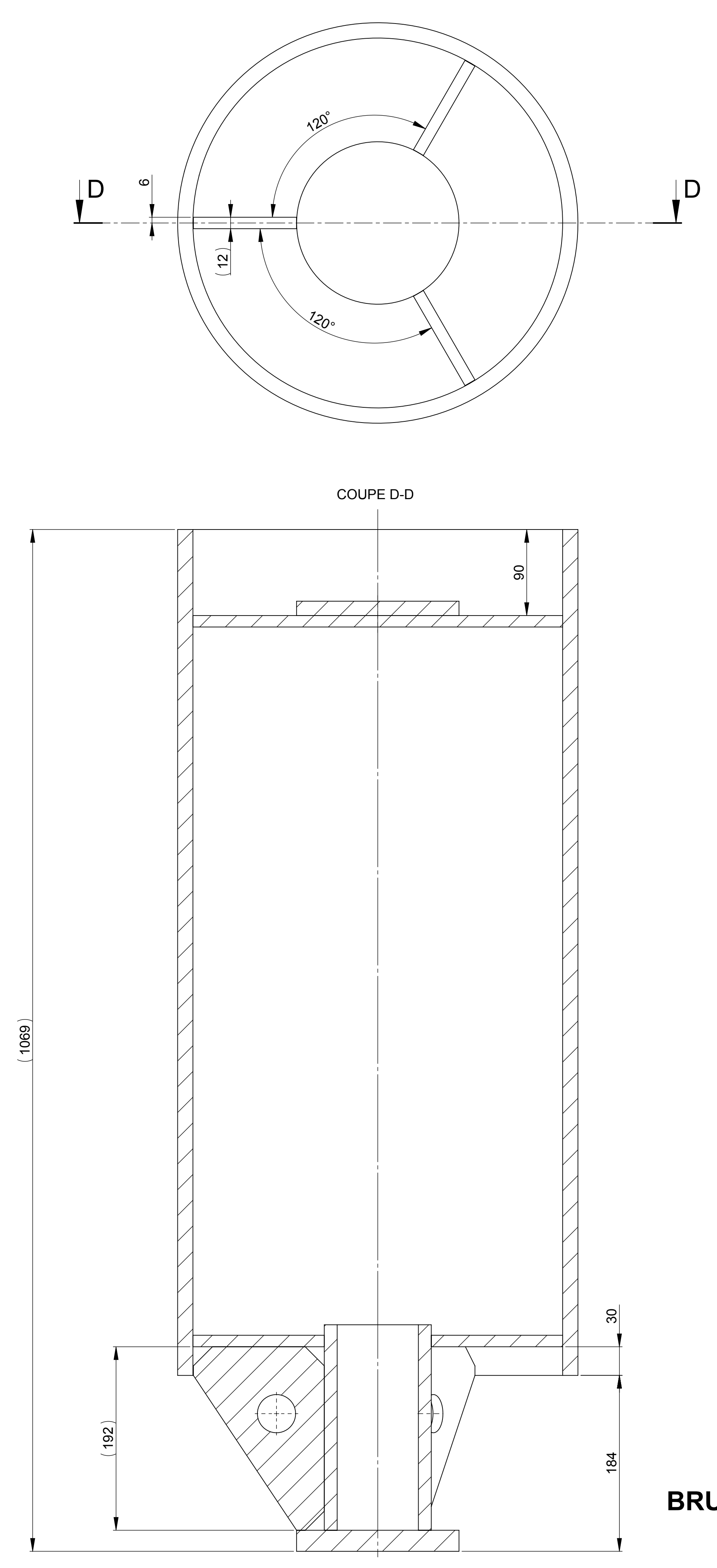
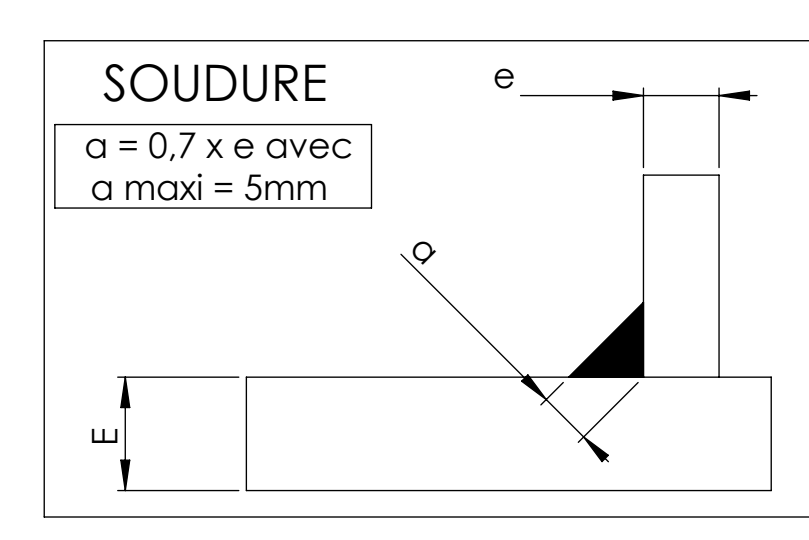

DATE	Echelle	SERVICE	NOM	IND.	IND.
05-10-15	1:3				
DESIGNATION: pièce sous-ensemble ou ensemble.					MATIERE: E24
ASSEMBLAGES GUIDE ET SIEGES.					TRAITEMENT: stabilisé
OP 311 CLEON					BRUT
BARILLET SIEGE					PEINTURE B
BARILLET C500					
RESPONSABLE D'AFFAIRE:			DESSINE PAR:		
NOM	SERVICE	ETABLISSEMENT	NOM	SERVICE	ETABLISSEMENT
ORIGINAL			COPIE		
FORMAT	CONCEPTION	ARCHIVAGE	FORMAT	CONCEPTION	ARCHIVAGE
A0	<input type="checkbox"/> MANUELLE	<input type="checkbox"/> INFORMATIQUE	A0	<input type="checkbox"/> MANUELLE	<input type="checkbox"/> INFORMATIQUE
VEHICULE OU ORGANE			PLANCHES		
F084010310			FOLIO 1		
MATRICULE			SUFFIXE		
N° MABEC BED			STANDARD		

Ra 6.3  
 Sauf indications contraires  
 Cotes sans Tolerance ISO 2768-mK  
 Casser les angles 0.5 à 45°  
 \* EMPLACEMENT DE MARQUAGE A MARQUER  
 -NUMERO R.N.U.R.  
 -DERNIER INDICE DE MODIF.  
 Masse = 156439.64g

Date: 05-10-15  
 Designation: Barillet C500  
 Base: 008  
 Vant: Ind  
 Form: A0  
 FOLIO 1/12  
 PO700-311-03-010

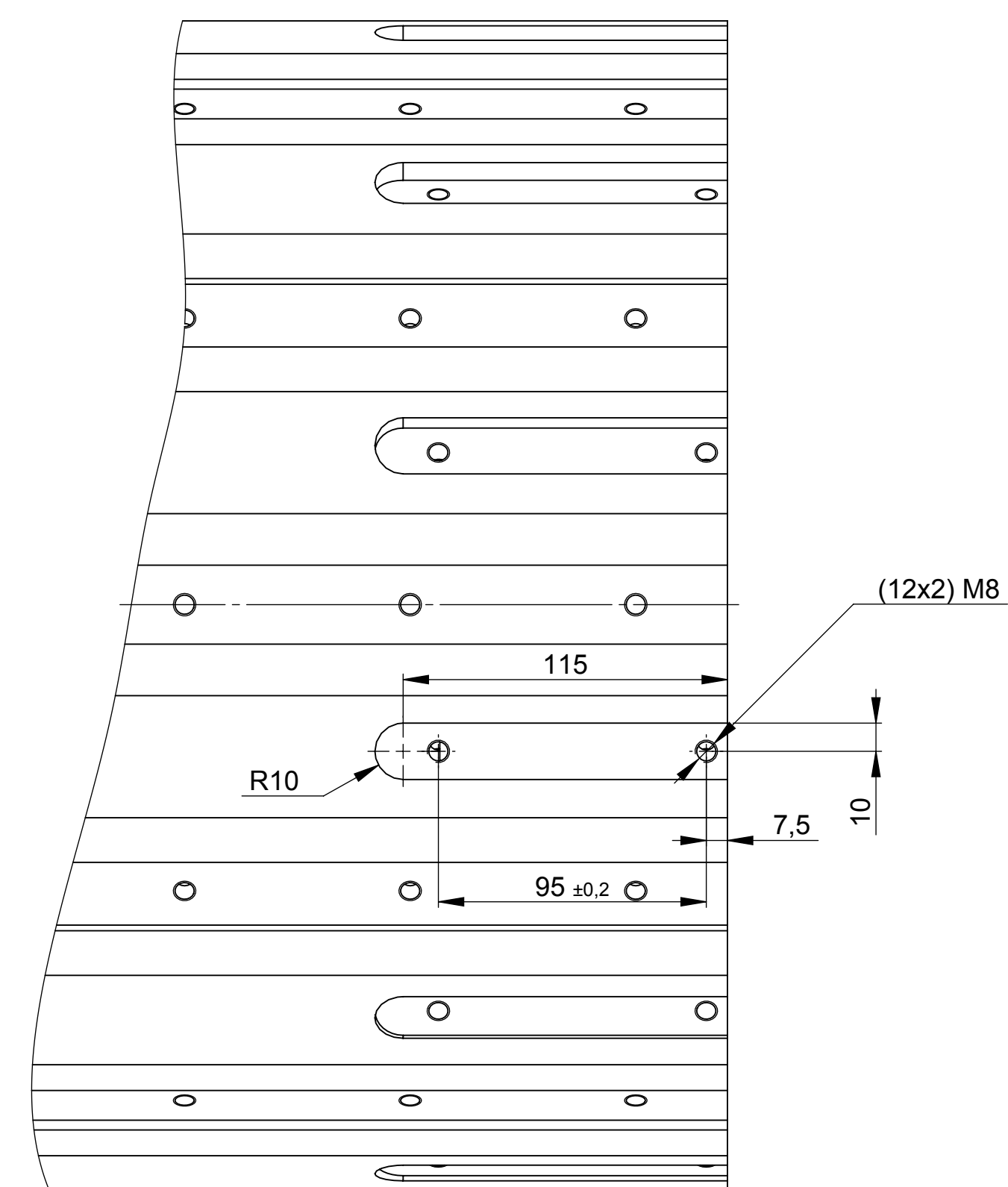
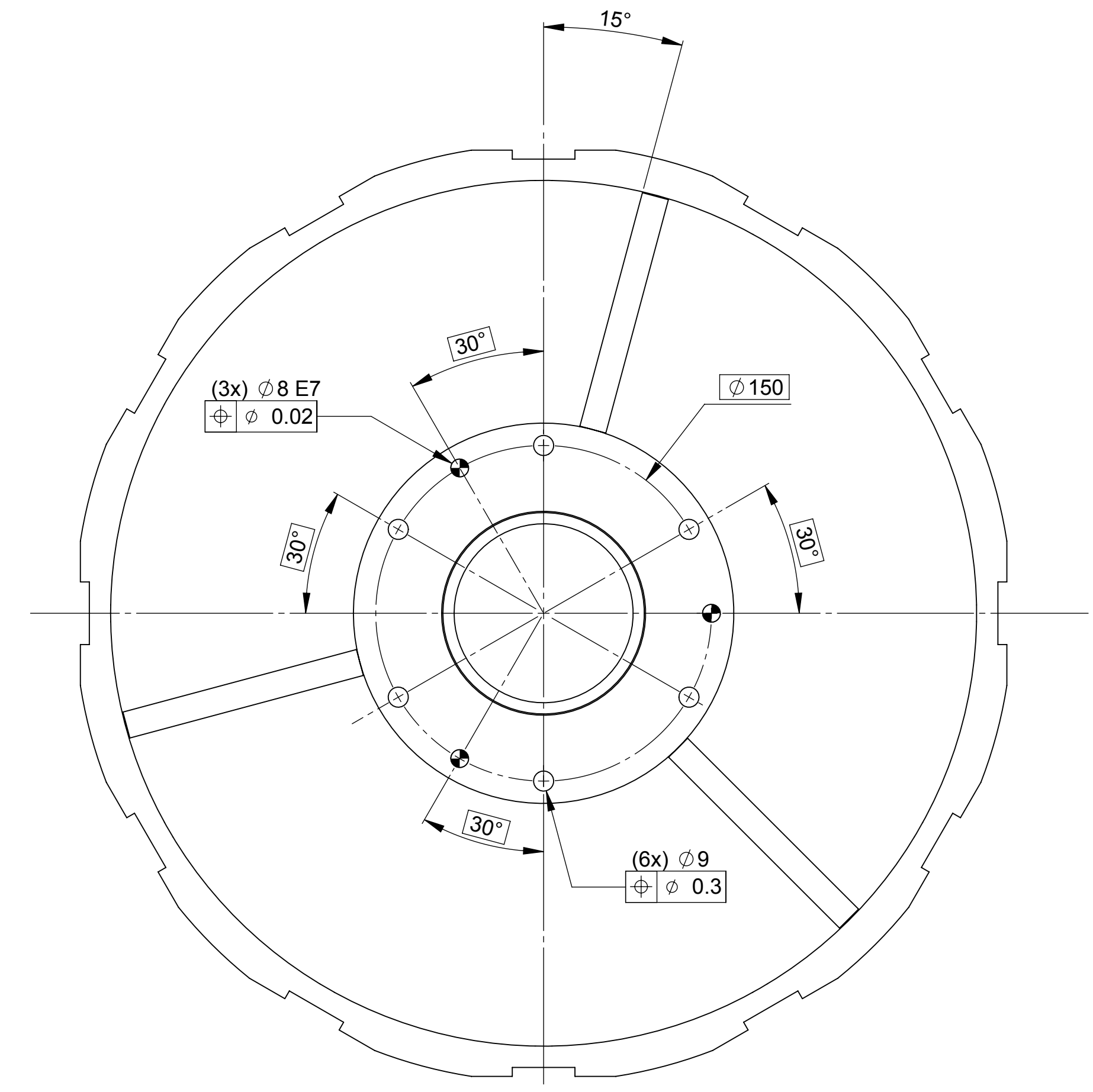
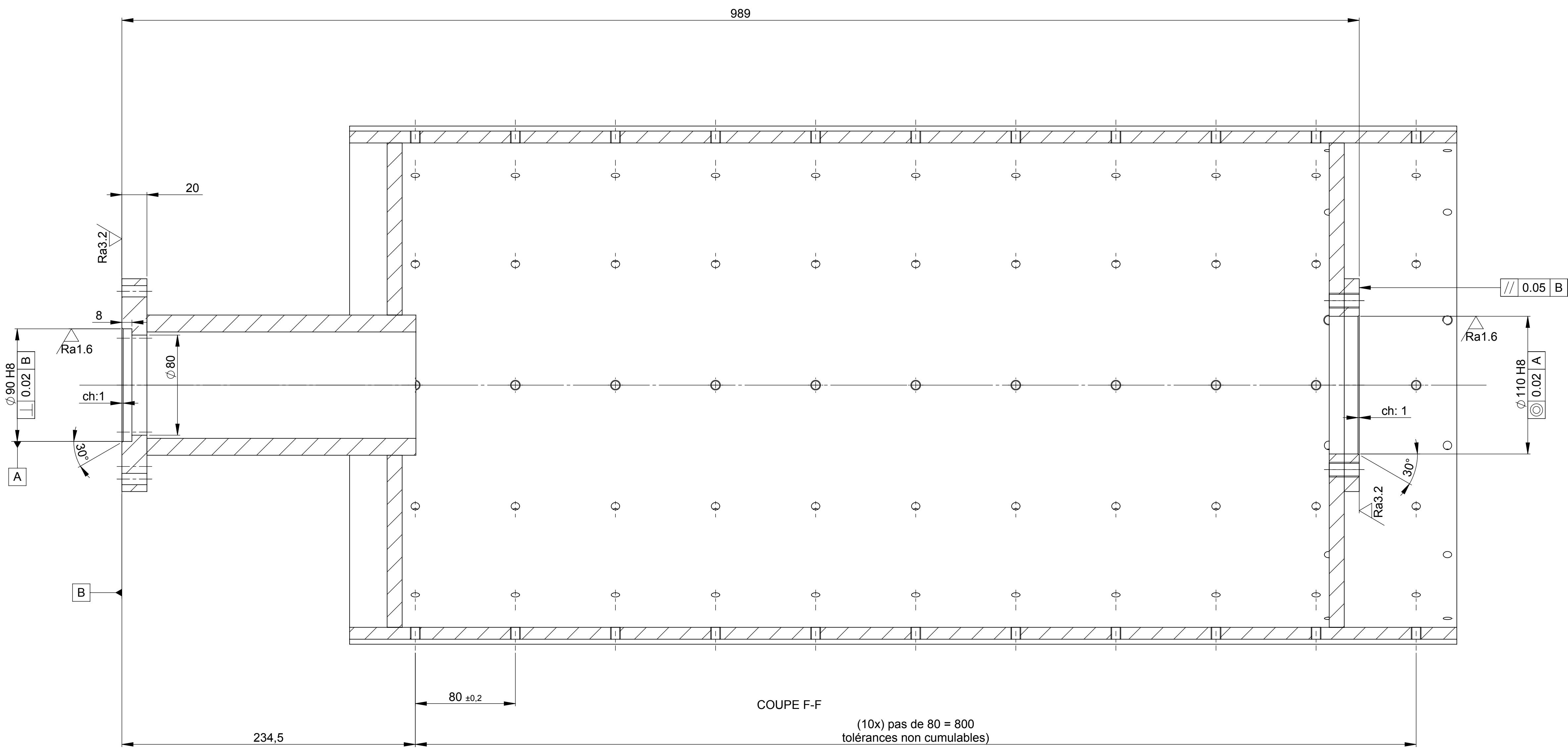
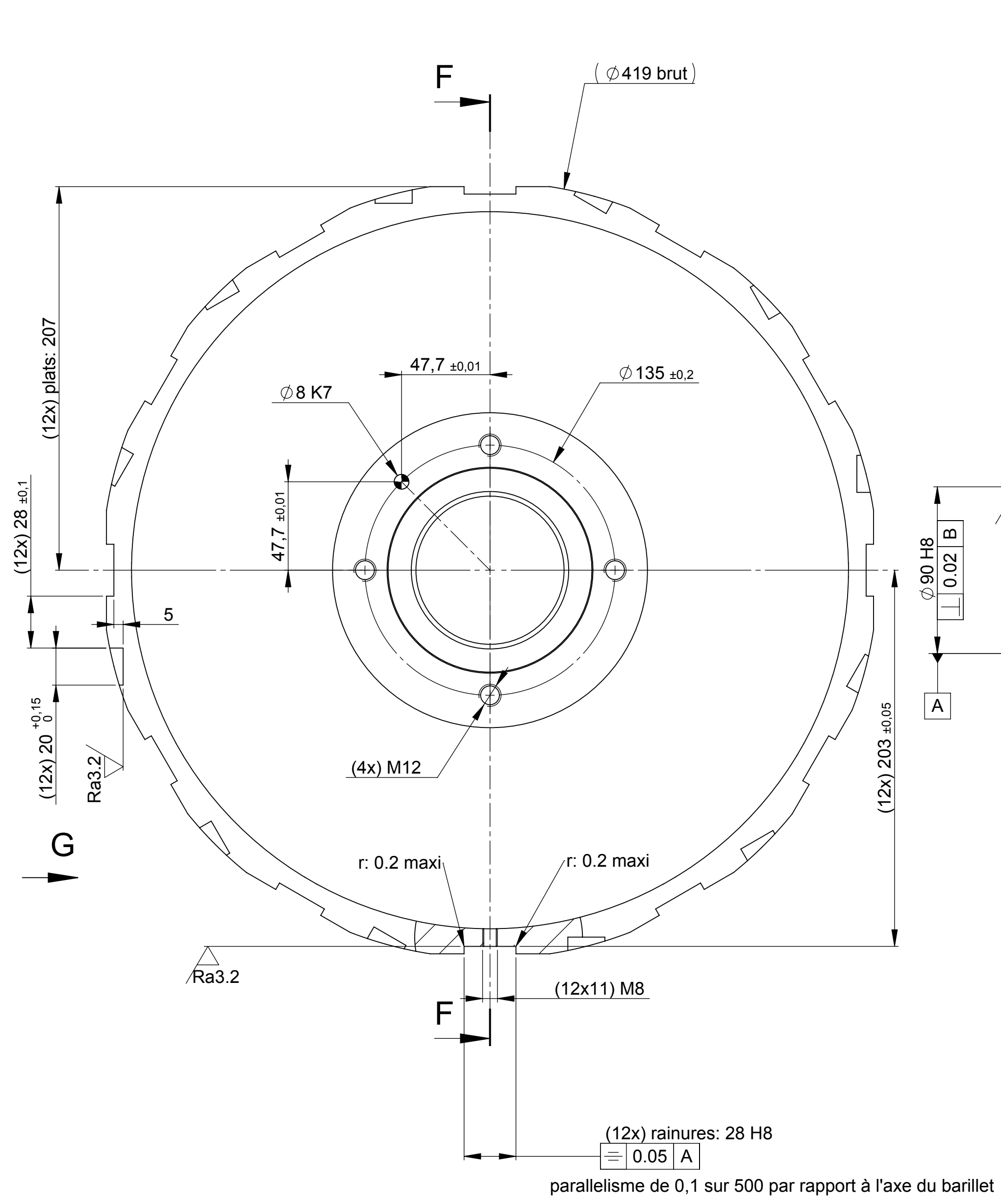

VUE suivant G

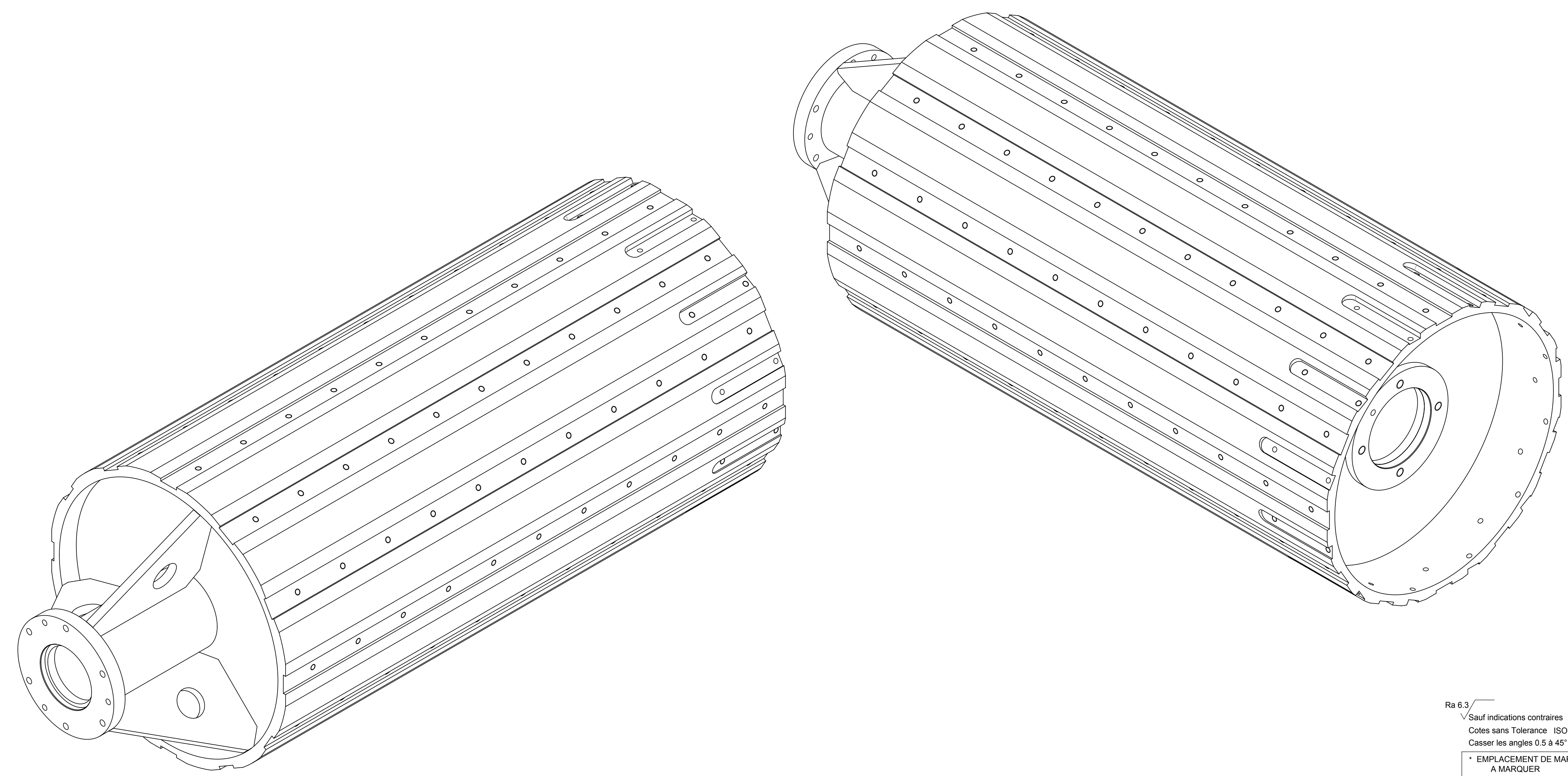

NOTA: FACES USINEES NON PEINTES

PEINTURE  
 COUCHE D'APPRET + LAQUE POLYURETHANE  
 SATINEE - SANS IMPRÉCISÉS  
 ET USINAGES

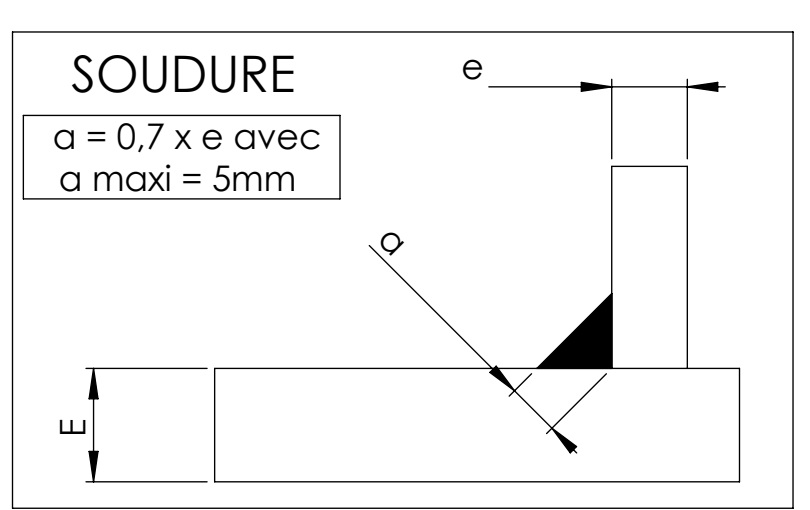

DATE	Echelle	SERVICE	NOM	MODIFICATIONS	IND.
05-10-15	1:2				A
DESIGNATION: pièce sous-ensemble ou ensemble.					E24
ASSEMBLAGES GUIDE ET SIEGES.					TRAITEMENT
OP 311 CLEON					standard
BARILLET SIEGE					BRUT
BARILLET C500					PEINTURE B
RESPONSABLE D'AFFAIRE:			DESSINE PAR:		
NOM	SERVICE	ETABLISSEMENT	NOM	SERVICE	ETABLISSEMENT
ORIGINAL			COPIE		
FORMAT	CONCEPTION	ARCHIVAGE	FORMAT	CONCEPTION	ARCHIVAGE
A0	MANUELLE		A0	MANUELLE	
	IMPRIMERIE			IMPRIMERIE	
AUTRE NUMERO:			AUTRE NUMERO:		
VEHICULE OU ORIGINE			VEHICULE OU ORIGINE		
FLANCHE			FLANCHE		
FOLIO 2			FOLIO 2		
MATRICULE			MATRICULE		
Etablissement			Etablissement		
N° MABEC BED			N° MABEC BED		
STANDARD			STANDARD		
SUFFIXE			SUFFIXE		

Ra 6.3  
 Sauf indications contraires  
 Cotes sans Tolerance ISO 2768-mK  
 Casser les angles 0.5 à 45°  
 \* EMPLACEMENT DE MARQUAGE A MARQUER  
 -NUMERO R.N.U.R.  
 -DERNIER INDICE DE MODIF.

Masse = 156439.64g

PO700-311-03-010