

SECTION D-D
SCALE 1 : 1

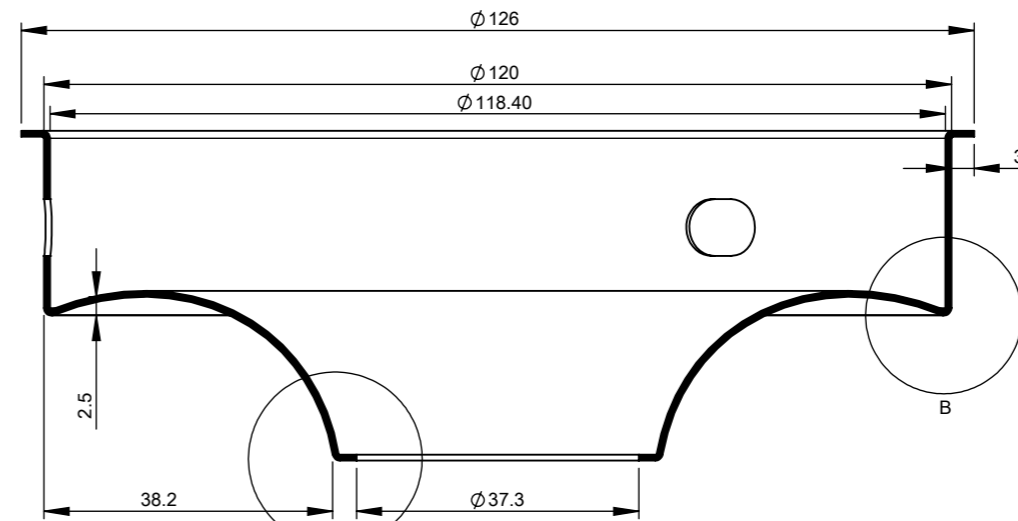

SECTION A-A
SCALE 1 : 1

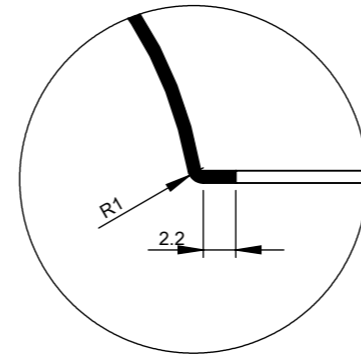

DETAIL C
SCALE 2 : 1

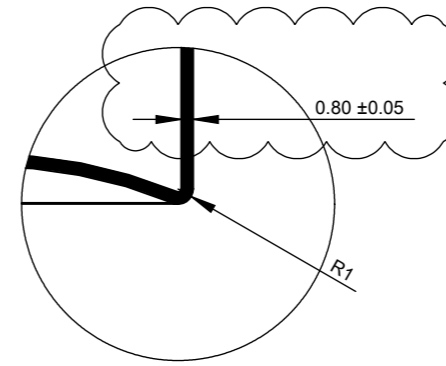

DETAIL B
SCALE 2 : 1

APPROVED FOR PRODUCTION

DEBURR AND BREAK SHARP EDGES	UNLESS OTHERWISE SPECIFIED: DIMENSIONS ARE IN MILLIMETERS TOLERANCES: LIN.: ± mm ANG.: ± deg.	APPROVALS		VITA Robinson Plaza, Room 739 Chengzhong Road 138 Jiading District 201800 Shanghai China
			NAME	
THE MATERIAL MUST BE ODOURLESS AND DUST-REPELLANT	MATERIAL: 1060 Alloy	DRAWN	Stanislaw Ploski	PROJECT: Acorn
		CHECKED	Stanislaw Ploski	
NO SCRATCHES, DENTS, FINGERPRINTS, BLEMISHES OF ANY KIND	SURFACE: Polished SURFACE TREATMENT: Anodized	APPROVED	Søren Ravn Christensen	PART: Reflector_Default
		COMMENTS:		PART NO.: 2081LP03 REV: A.001
COLOR MUST BE LIGHTFAST AND CONSISTENT	COLOR: See Sheet 2, "Color variants" WEIGHT: 46.91g			DATE: 22-03-2016
				Designed by Jacob Rudbeck
				A3
				SCALE: 1:1 SHEET 1 OF 2

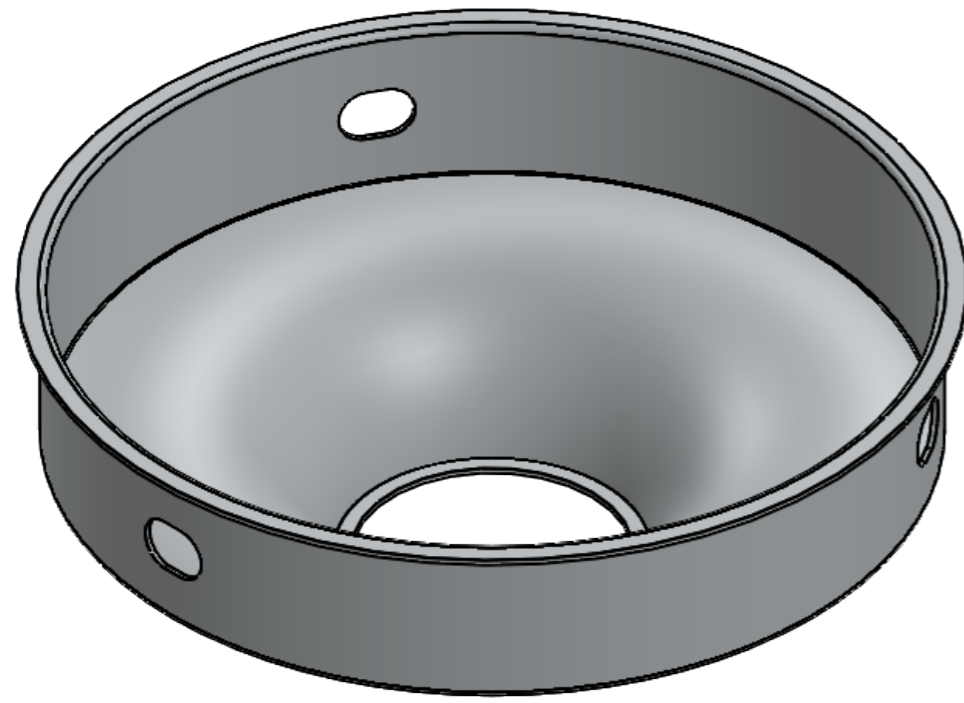

Polished steel
 Part no.: 2081LP03
 Polished 1060 Aluminium
 Surface treatment: Anodized
 Color: Natural aluminium

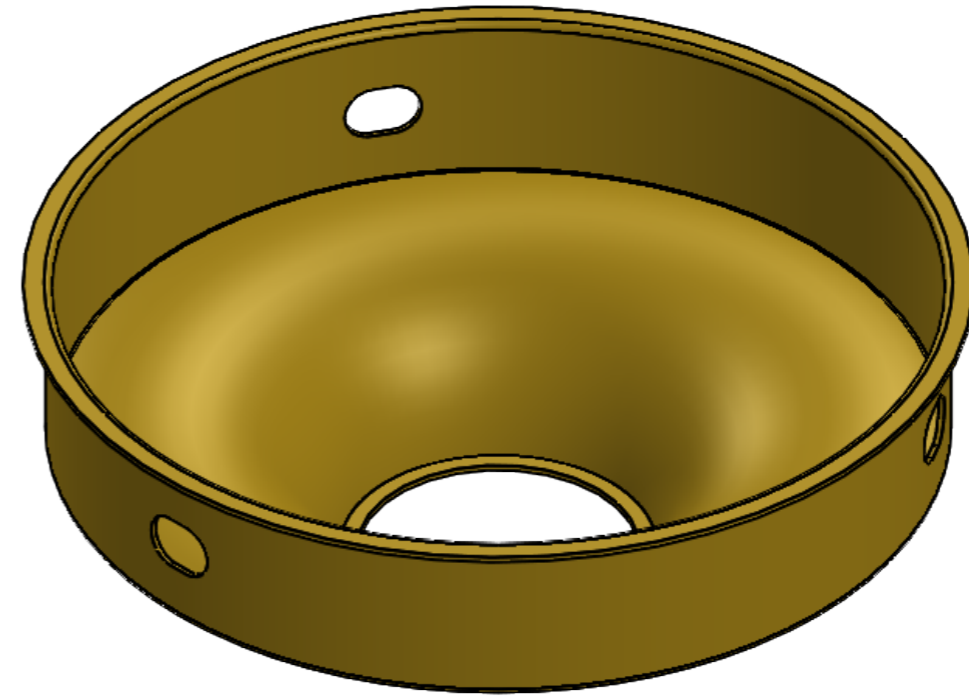

Polished brass
 Part no.: 2082LP01
 Polished 1060 Aluminium
 Surface treatment: Anodized
 Color: Brass

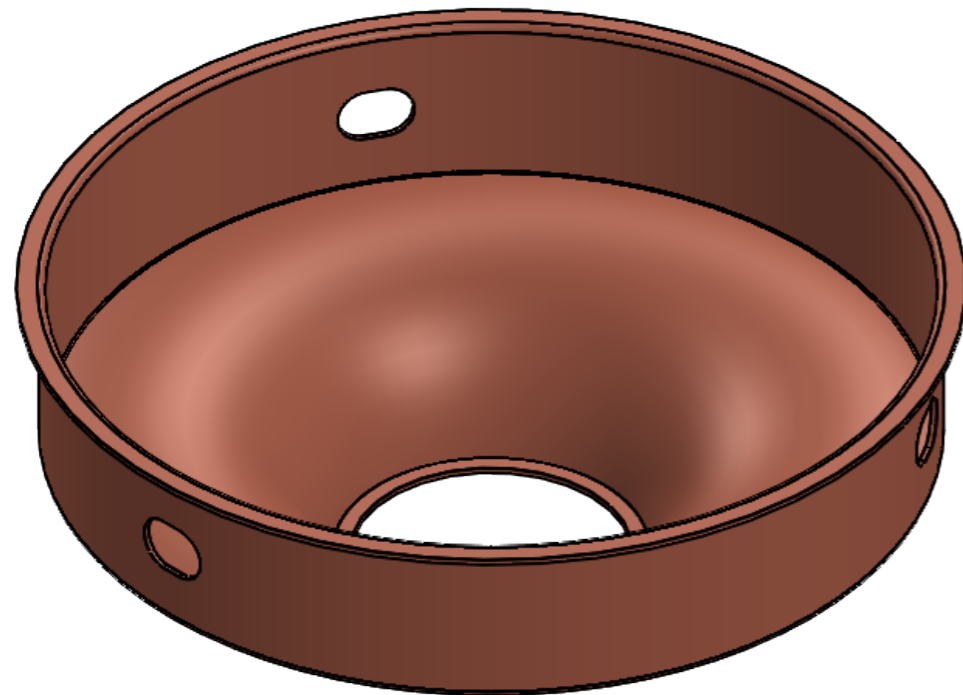

Polished copper
 Part no.: 2083LP01A
 Polished 1060 Aluminium
 Surface treatment: Anodized
 Color: Copper

APPROVED FOR PRODUCTION

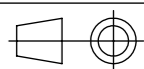
DEBURR AND BREAK SHARP EDGES	UNLESS OTHERWISE SPECIFIED: DIMENSIONS ARE IN MILLIMETERS TOLERANCES: LIN.: ± mm ANG.: ± deg.	APPROVALS		 Robinson Plaza, Room 739 Chengzhong Road 138 Jiading District 201800 Shanghai China
			NAME	
THE MATERIAL MUST BE ODOURLESS AND DUST-REPELLANT	MATERIAL: 1060 Alloy	DRAWN	Stanislaw Ploski	PROJECT: Acorn
		CHECKED	Stanislaw Ploski	
NO SCRATCHES, DENTS, FINGERPRINTS, BLEMISHES OF ANY KIND	SURFACE: Polished SURFACE TREATMENT: Anodized	APPROVED	Søren Ravn Christensen	PART: Reflector_Default
		COMMENTS:		PART NO.: 2081LP03 REV: A.001
COLOR MUST BE LIGHTFAST AND CONSISTENT	COLOR: See drawing WEIGHT: 46.91g			DATE: 22-03-2016
				Designed by Jacob Rudbeck
				<div style="display: flex; justify-content: space-between;"> A3  </div>
				SCALE: 1:1 SHEET 2 OF 2
TM and © 2015 VITA lighting ApS. All rights reserved.			Do NOT scale drawing	