



Material: 1.4301, 1,0 mm

POZ.	NÁZEV	KS
1	Spojka B	40
2	Spojka C	32
3	Spojka F	4
4	Spojka I	4
5	Spojka J	8
6	Spojka K	22
7	Spojka L	60
8	Spojka M	10
9	Spojka N	4
10	Spojka O	4
11	Spojka P	2
12	Spojka Q	12
13	Spojka R	10
14	Spojka S	18
15	Spojka T	20
16	Spojka U	4
17	Spojka V	12
18	Spojka W	6
19	Spojka X	8
20	Spojka 135	26
21	Spojka 90	38
22	Spojka 45	6

KRESLIL	DALIBOR DOUBEK	MATERIÁL	
DATUM	5. září 2017 15:29:55	TLOUŠŤKA	
	A4	1:5	HMOTNOST(g) 3188.36
	SPOJKY		
NÁZEV			ZKRATKA LIST: 1 LISTŮ: 3

1

2

3

4

5

6

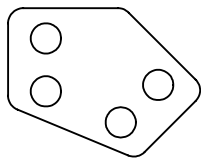

Spojka B

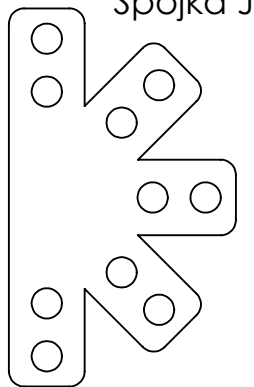

Spojka J

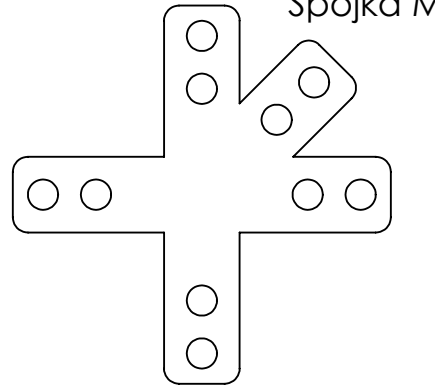

Spojka M

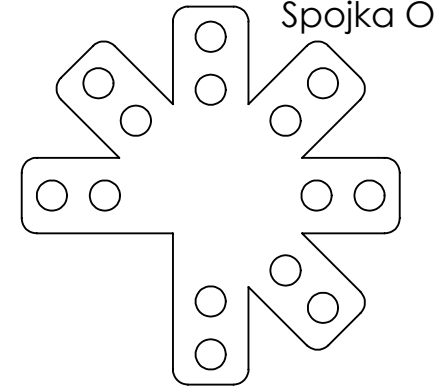

Spojka O

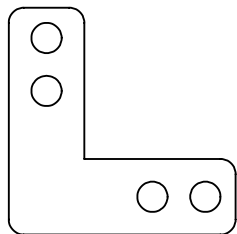

Spojka C

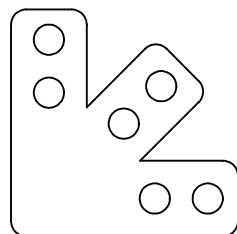

Spojka F

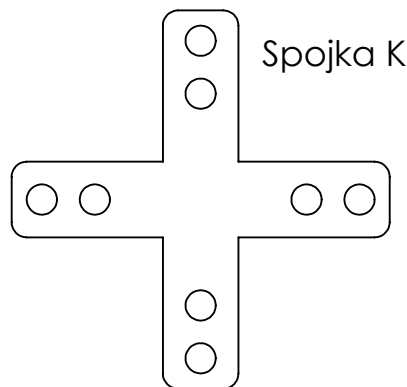

Spojka K

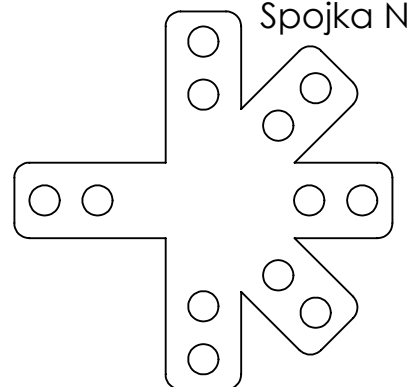

Spojka N

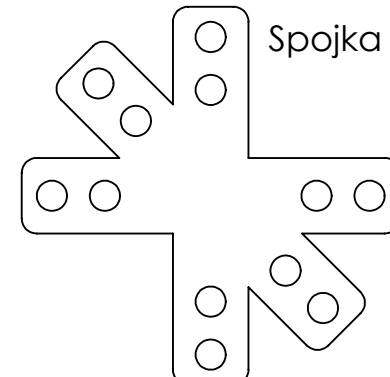

Spojka P

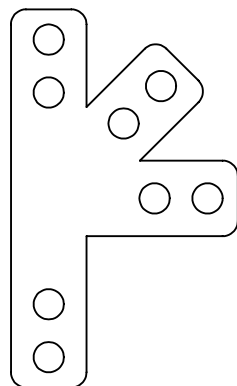

Spojka I

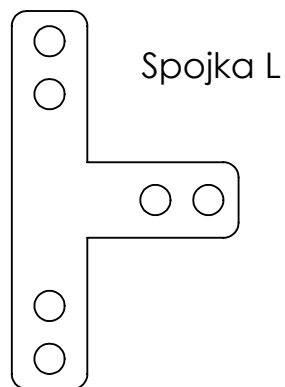

Spojka L

KRESLIL	DALIBOR DOUBEK		MATERIÁL	
DATUM	5. září 2017 15:29:55		TLOUŠŤKA	
	A4	1:1	HMOTNOST(g)	3188.36
	SPOJKY			
NÁZEV				ZKRATKA LIST: 2 LISTŮ: 3

1

2

3

4

5

6

A

A

B

B

C

C

D

D

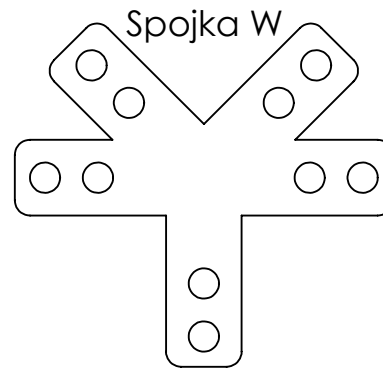
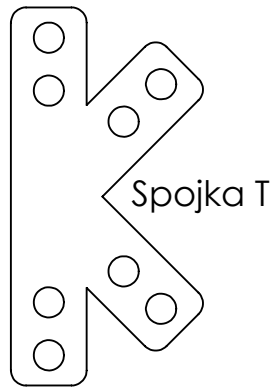
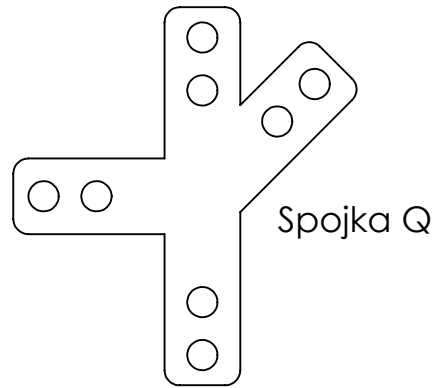

Spojka 135

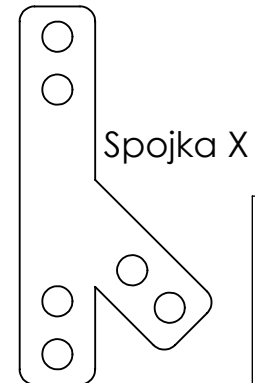
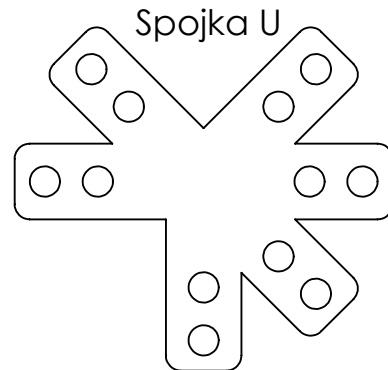
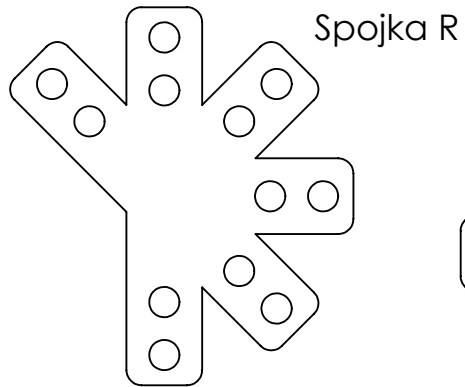
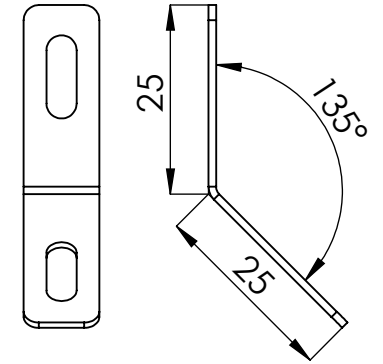

Spojka 90

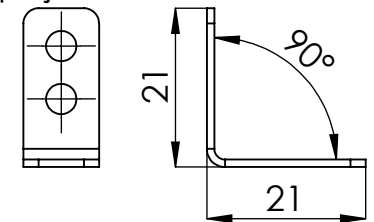

Spojka 45

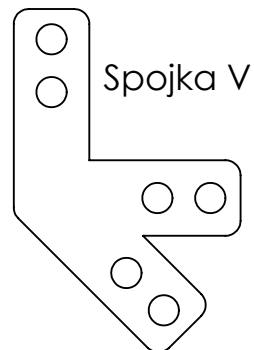
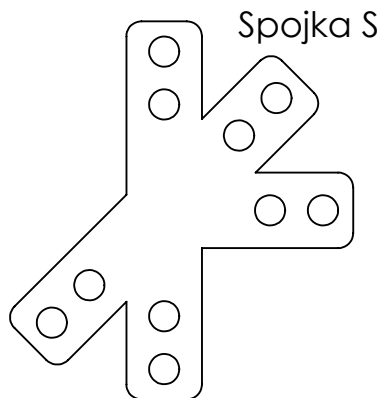
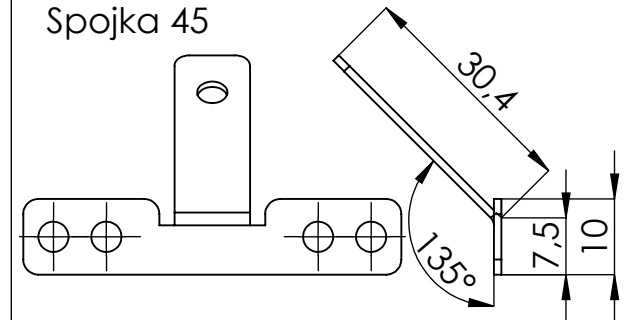

KRESLIL	DALIBOR DOUBEK	MATERIÁL	
DATUM	5. září 2017 15:29:55	TLOUŠŤKA	
	A4	1:1	HMOTNOST(g) 3188.36
	SPOJKY		
NÁZEV			ZKRATKA LIST: 3 LISTŮ: 3