

Coupe A-A

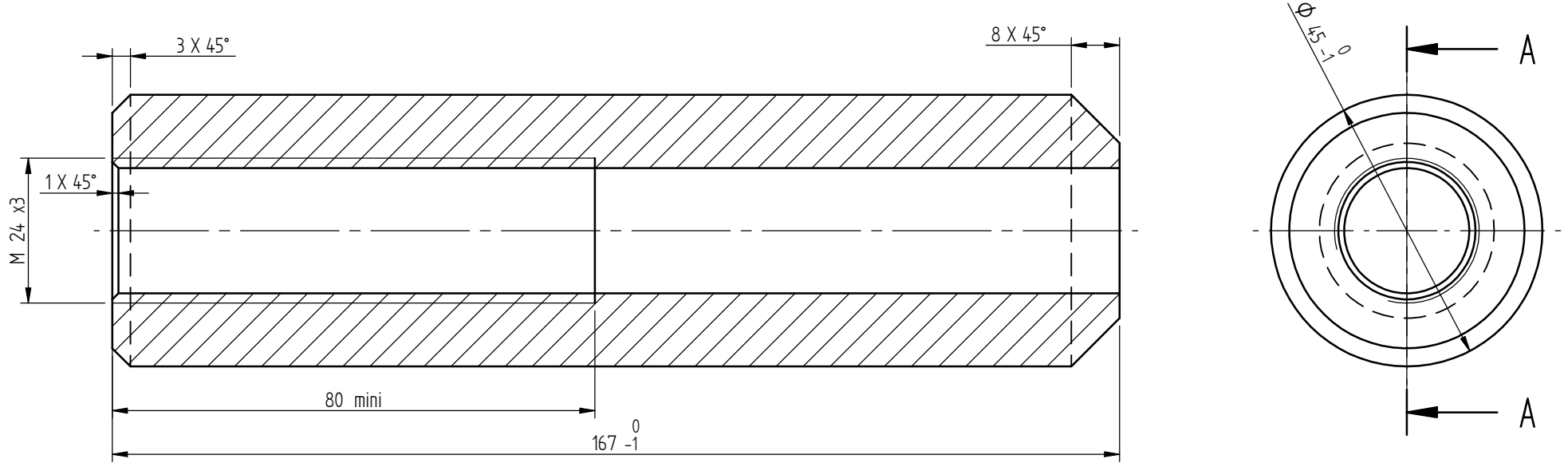

Tolérance générale: ± 1

F00	04/07/2018	modification longueur passe de 175 a 167mm	CB	CD
Ind	Date	Modifications	Dess.	Véri
		MATIERE / TRAITEMENT: Acier S355J2H Brut	TOL.GENERALE: ISO 2768.mK	DESSINE PAR: [REDACTED]
		DESIGNATION: [REDACTED]	DATE: 03/12/2010	VERIFIE PAR: --
		D.45 M24X 167	ECH.: 1:1	PL.: 1/1
			VALIDE PAR: --	IND: F
			CODE ARTICLE: 003106	