

ŘEZ A-A

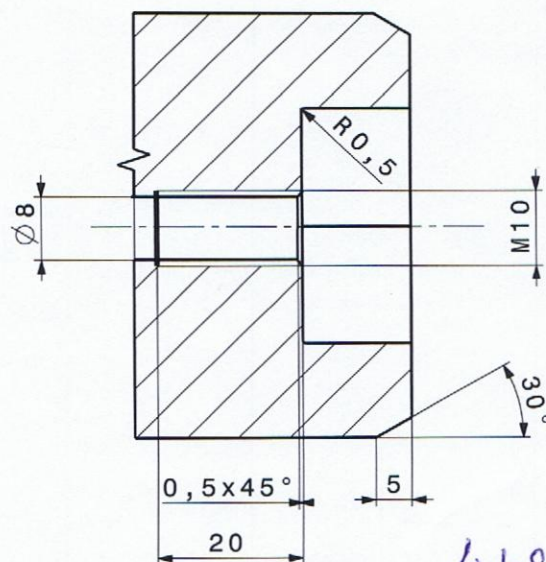

NEKÓTOVANÉ SRAŽENÍ 1x45°

EN/DE: ECCENTRIC ROD / EXENTERWELLE		
HŘÍDEL NOSNÁ		
KS Poz./St.	NÁZEV PV DÍLU	POZ.
	ČÍSLO ZAKÁZKY	Materiál: 1.2312 Měřitko: 1:3 Platnost od: 1. 8. 2013
		PV 02 0 204 00.1

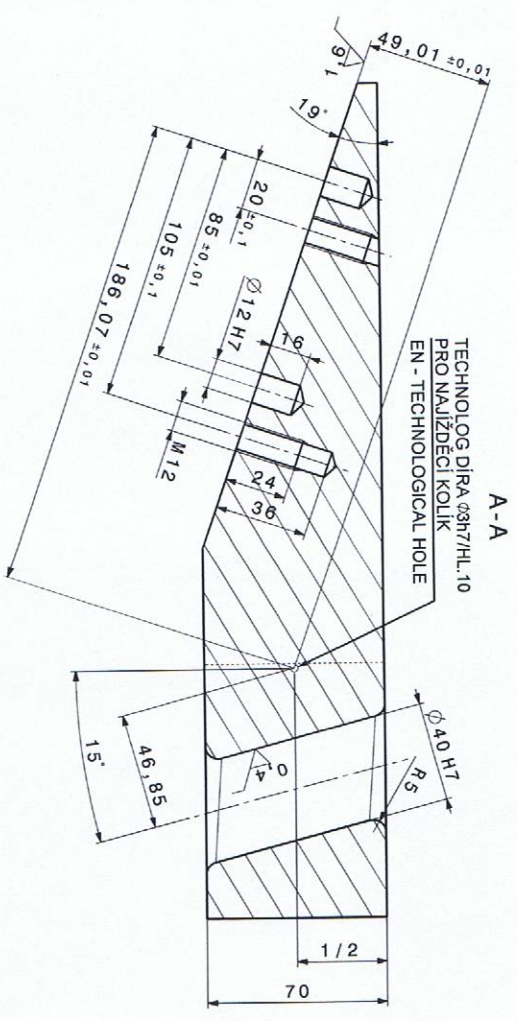
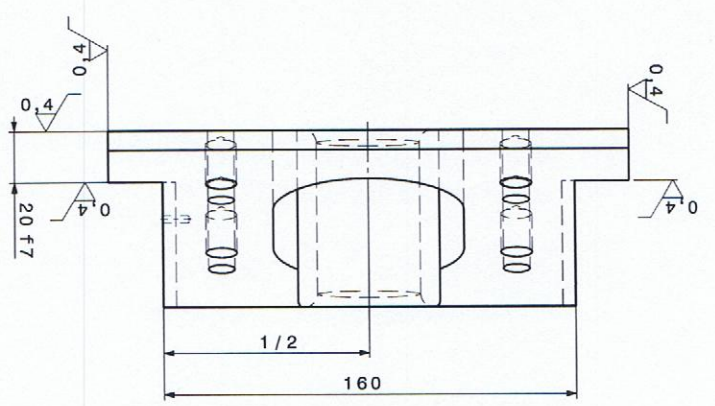
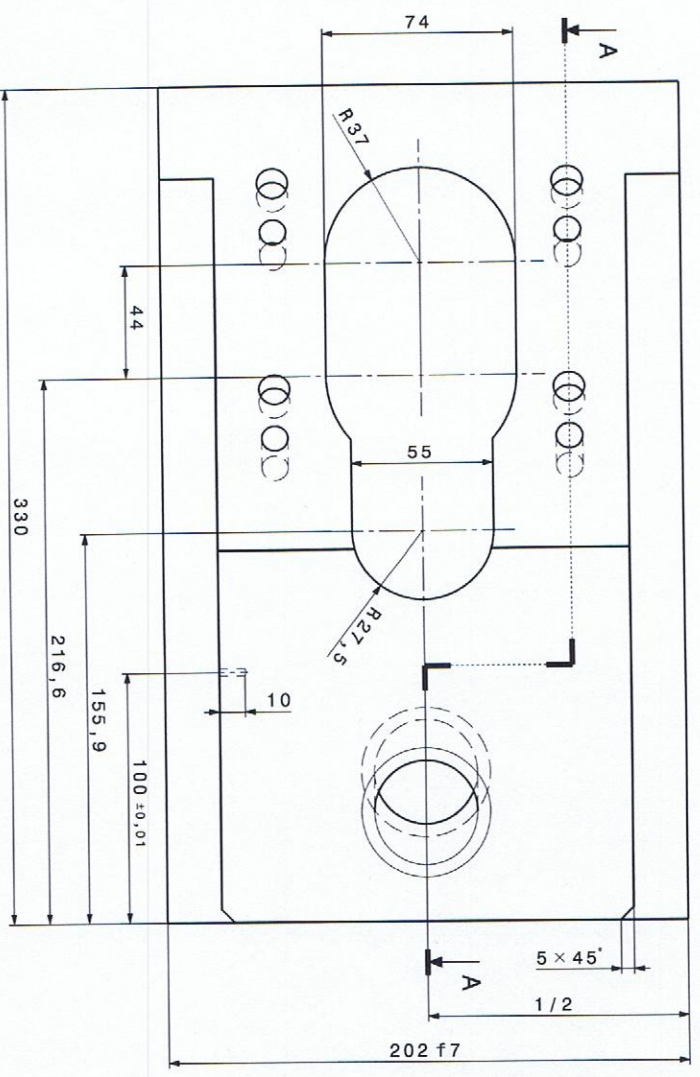

A-A
 TECHNOLOG DÍRA Ø3h7/HL.10
 PRO NAIŽDĚCÍ KOLÍK
 EN - TECHNOLOGICAL HOLE

POS. 5287 VYROBIT JAK JE NAKRESLENO
 Pos. 5287 produce by drawing
 POS. 5288 VYROBIT ZRCADLOVĚ
 Pos. 5288 produce as mirror image

N01

Pos.	NÁZEV Part name	ROZMĚR (ČISTÝ) Dimension (clear)	MATERIAL Material	POZNÁMKA Remark	POS. Pos.
1z	Deska	330x202x70	1.2343		5288 Z
1	Deska	330x202x70	1.2343		5287

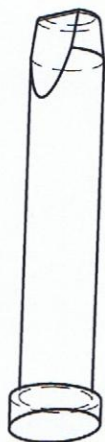

A-A
2:1

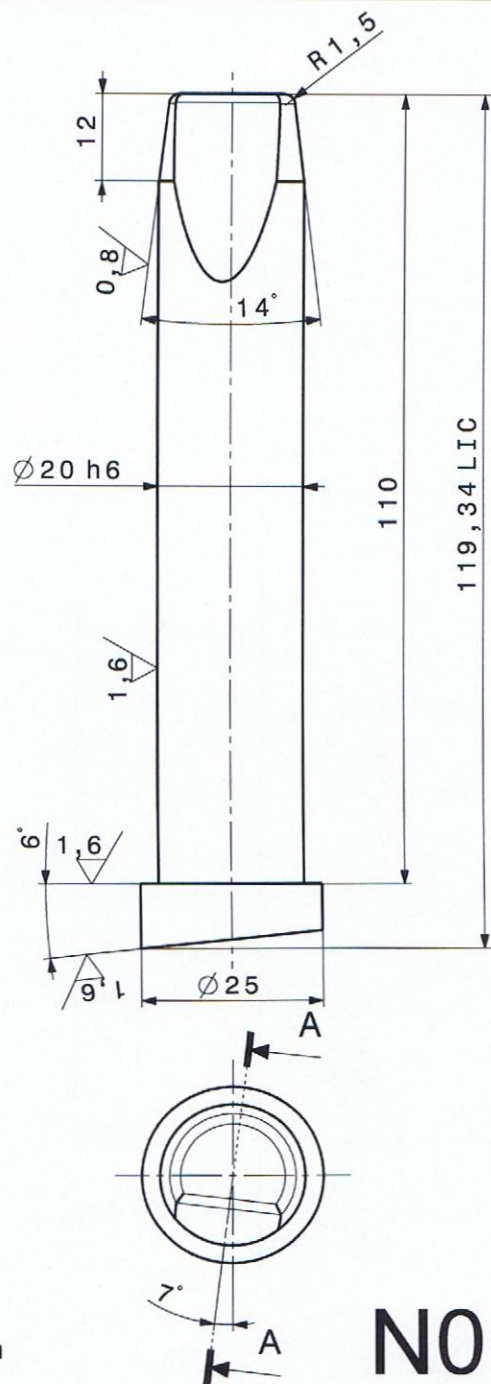
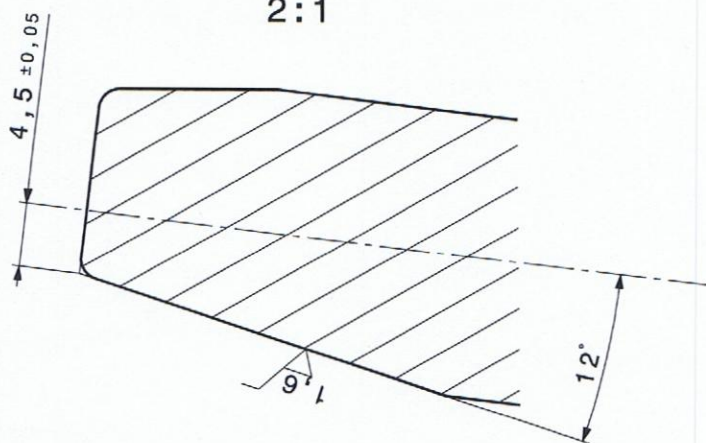

POS. 263 VYROBIT JAK JE NAKRESLENO

Pos. 263 produce by drawing

POS. 264 VYROBIT ZRCADLOVĚ

Pos. 264 produce as mirror image

TVAROVÉ PLOCHY DLE CAD-DAT V TOLERANCI ± 0.03 mm

Shape surfaces by CAD-DAT in tolerance ± 0.03 mm

N01

1	Kolik	d25x120	1.2311		264z
1	Kolik	d25x120	1.2311		263
KUSU Pcs.	NÁZEV Part name	ROZMĚR (ČISTÝ) Dimension (clear)	MATERIÁL Material	POZNÁMKA Remark	POS. Pos.

6,3

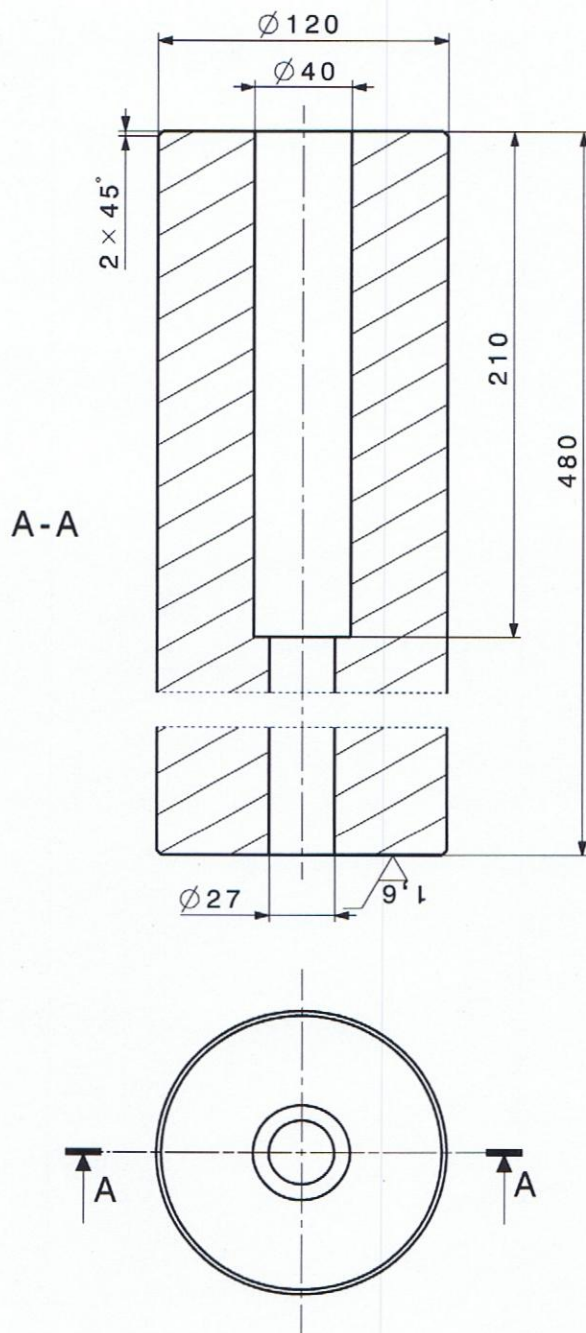

N01

4	Noha Formy	d120x480	11 523.1		5189
KUSU	NÁZEV	ROZMĚR (ČISTÝ)	MATERIÁL	POZNÁMKA	POS.