

MODIFICATIONS			
REV.	DESCRIPTION	AUTEUR	DATE
B	MAJ Nota. / zone conique retirée => cylindrique plus simple	T.CHIN	23/10/2017
C	MAJ Nota.	T.CHIN	27/11/2017

NOTA :
 Traitement : Zingage blanc épaisseur 10µm +/- 3 µm
 Les tolérances dimensionnelles et géométriques doivent tenir compte de l'épaisseur du traitement de surface.

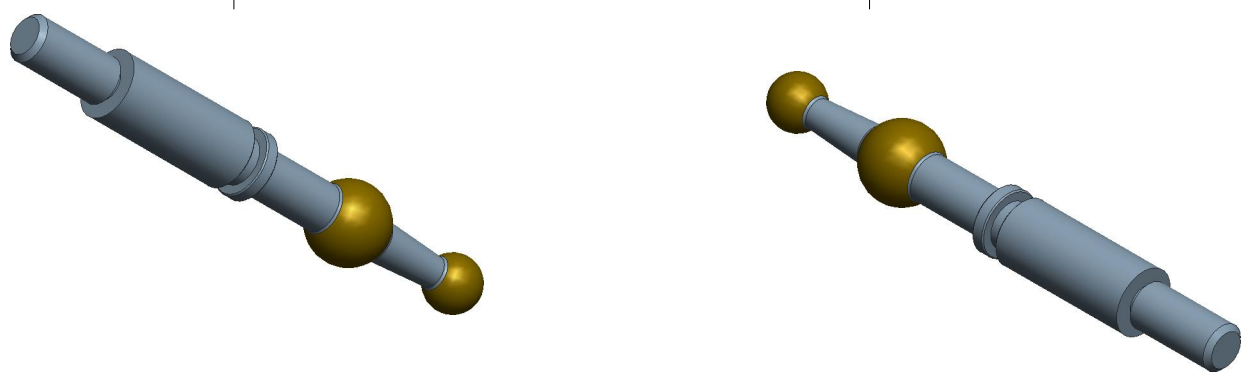
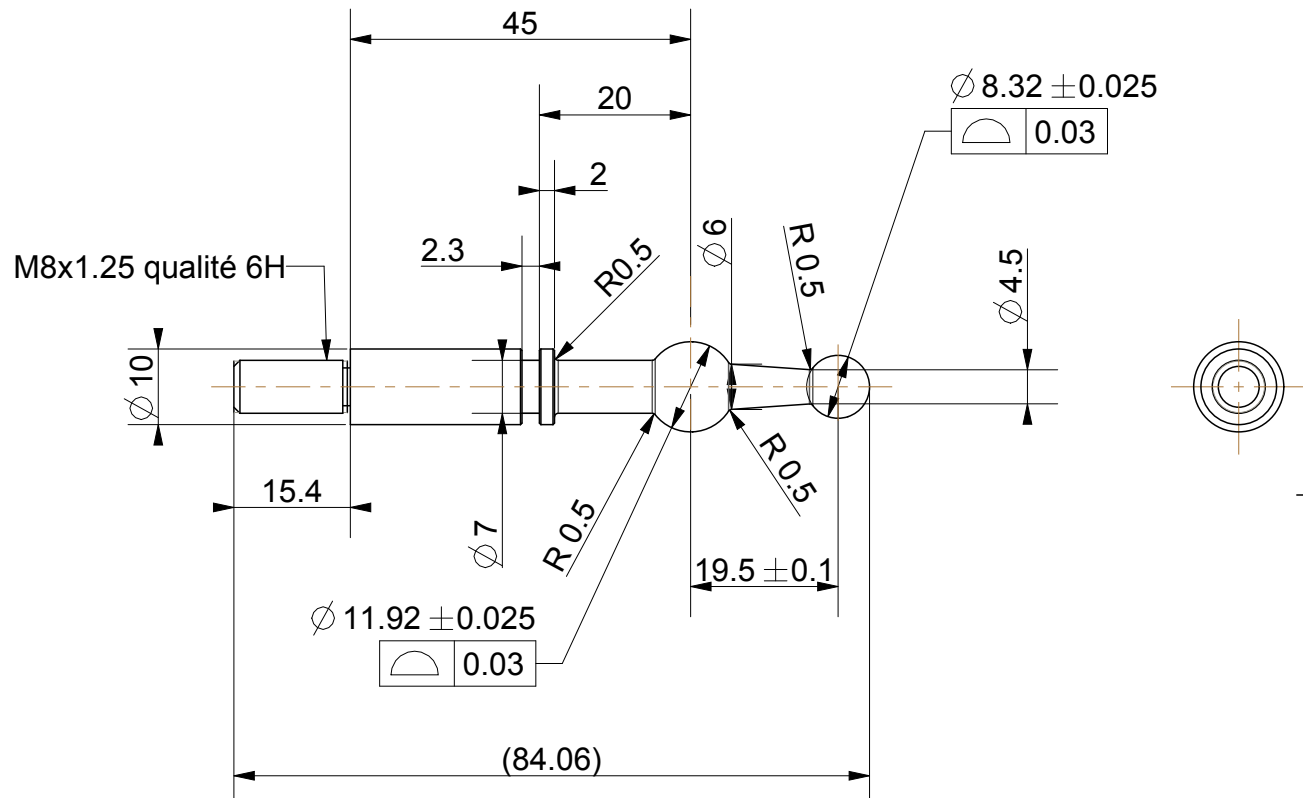

MATIERE/MATERIAL	Acier 40 CMD 8 (ou équivalent)		MASSE /WEIGHT	TOL. GEN. /GEN. TOL. ISO 2768-mk	ECH. /SCALE	1.000	FORMAT	A4	
TRAITEMENT/TREATMENT	Voir NOTA.		---	---	---	---	---	---	---
FINITION/FINISH	---		---	---	---	---	---	---	---
DESSINE/DRAWN	DATE	VERIFIE/CHECKED	DATE	APPROUVE/APPROVED		DATE	---		
T.CHIN	27/10/2016	C.ECHAVE	27/10/2016	G.CASSAGNE		27/10/2016	---		
TITRE/TITLE	Levier de direction								
REFERENCE							REV.	PAGE	
MEC.161964.260.1							C	1/1	