

Lakováno barvou JOTUN, RAL 5017, hladká, označení výrobce 1026674 PX20

Rozvinutý tvar upravit s ohledem na použité nástroje, aby byly dodrženy rozměry po ohybu.

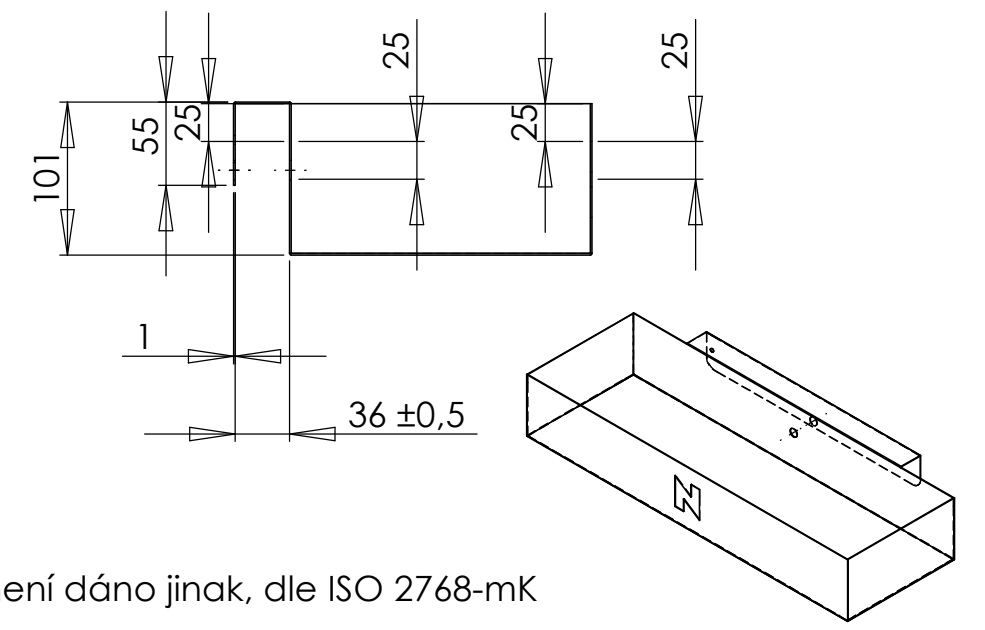
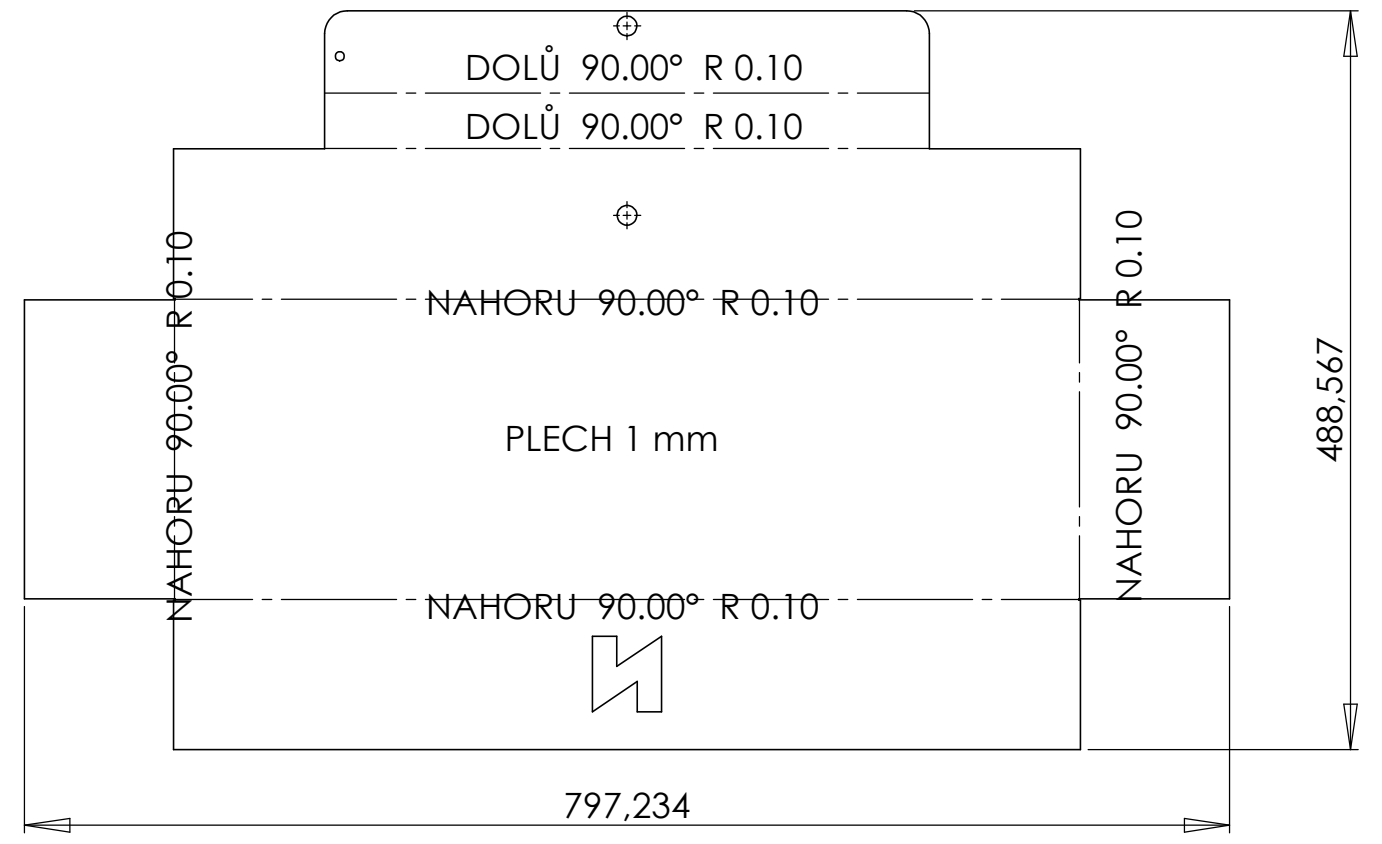

27.10.2015

Tolerance, pokud není dáno jinak, dle ISO 2768-mK

UNLESS OTHERWISE SPECIFIED: DIMENSIONS ARE IN MILLIMETERS SURFACE FINISH: TOLERANCES: LINEAR: ANGULAR:				FINISH:		DEBUR AND BREAK SHARP EDGES		DO NOT SCALE DRAWING		REVISION	
DRAWN				SIGNATURE		DATE		TITLE: <h1>Toolbox</h1>			
CHKD											
APPV'D											
MFG											
Q.A						MATERIAL:		DWG NO. 05 01		A3	
						WEIGHT:		SCALE:1:5		SHEET 1 OF 1	