

Vues ISO

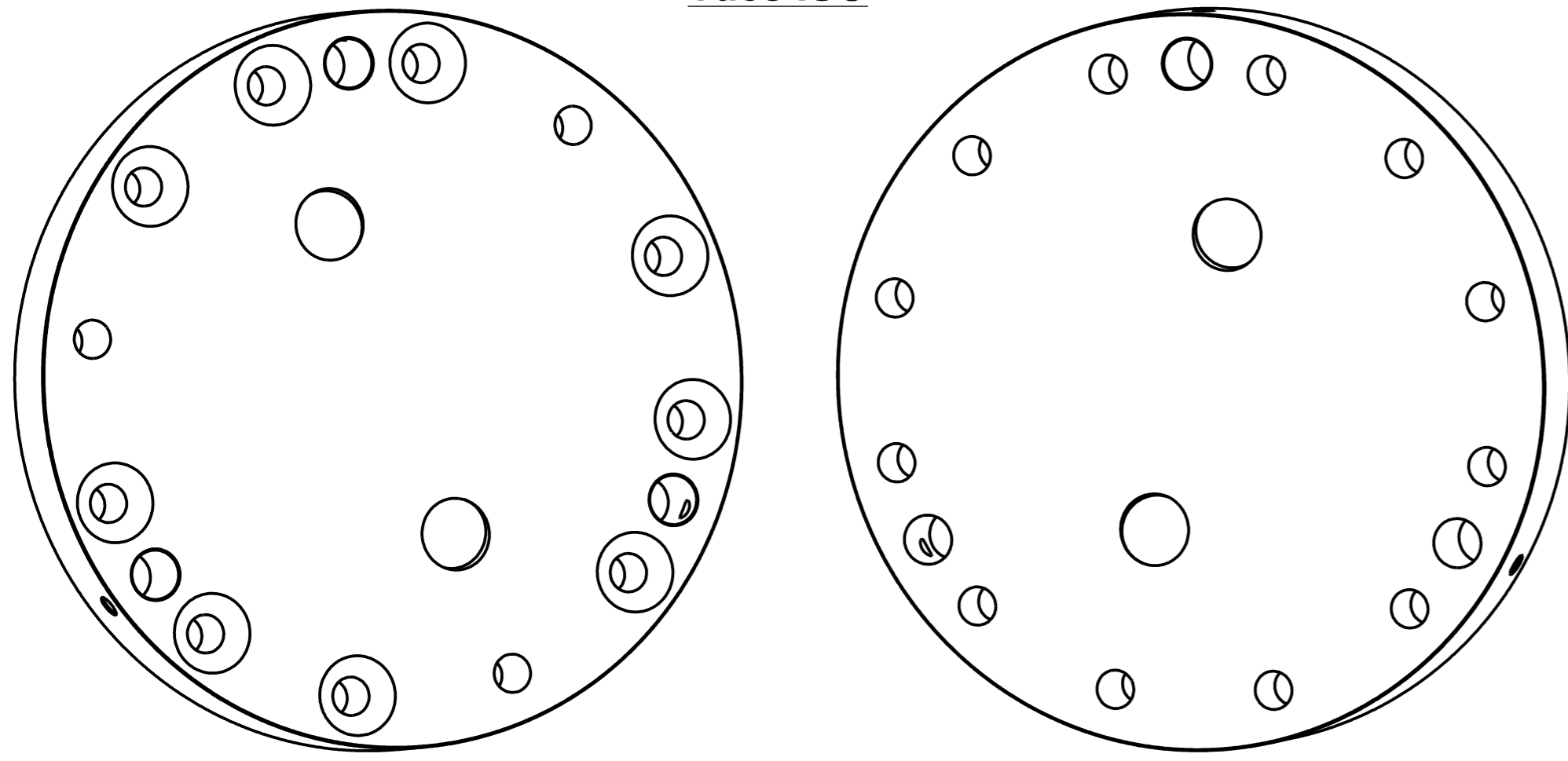

C-C Ech: 1:1

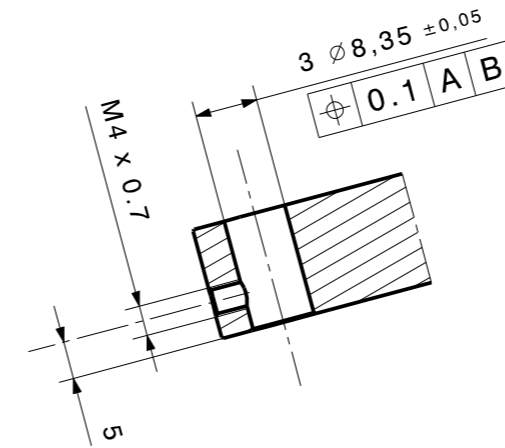

Détail B Ech 5:1
4 Usinages identiques

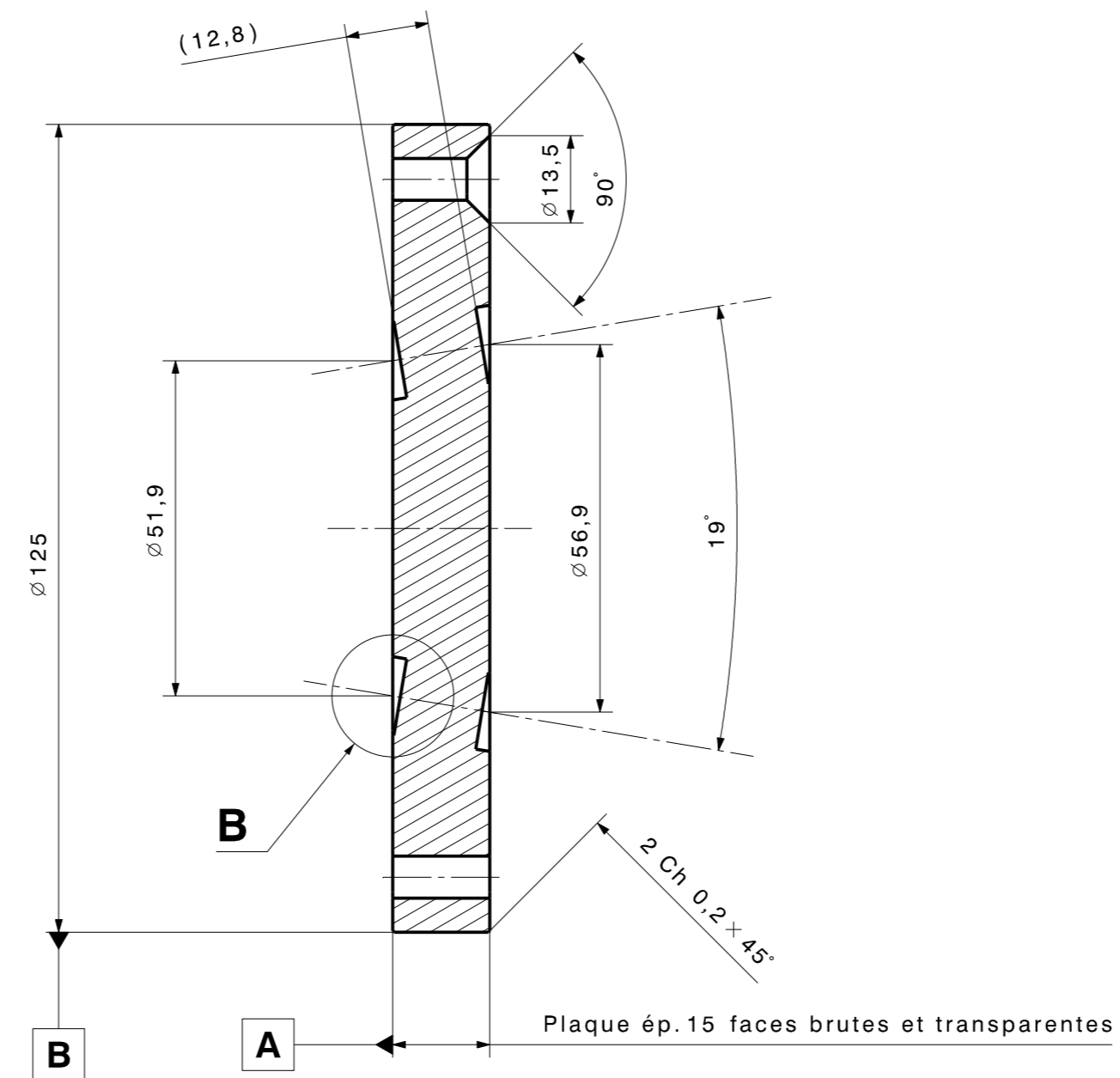
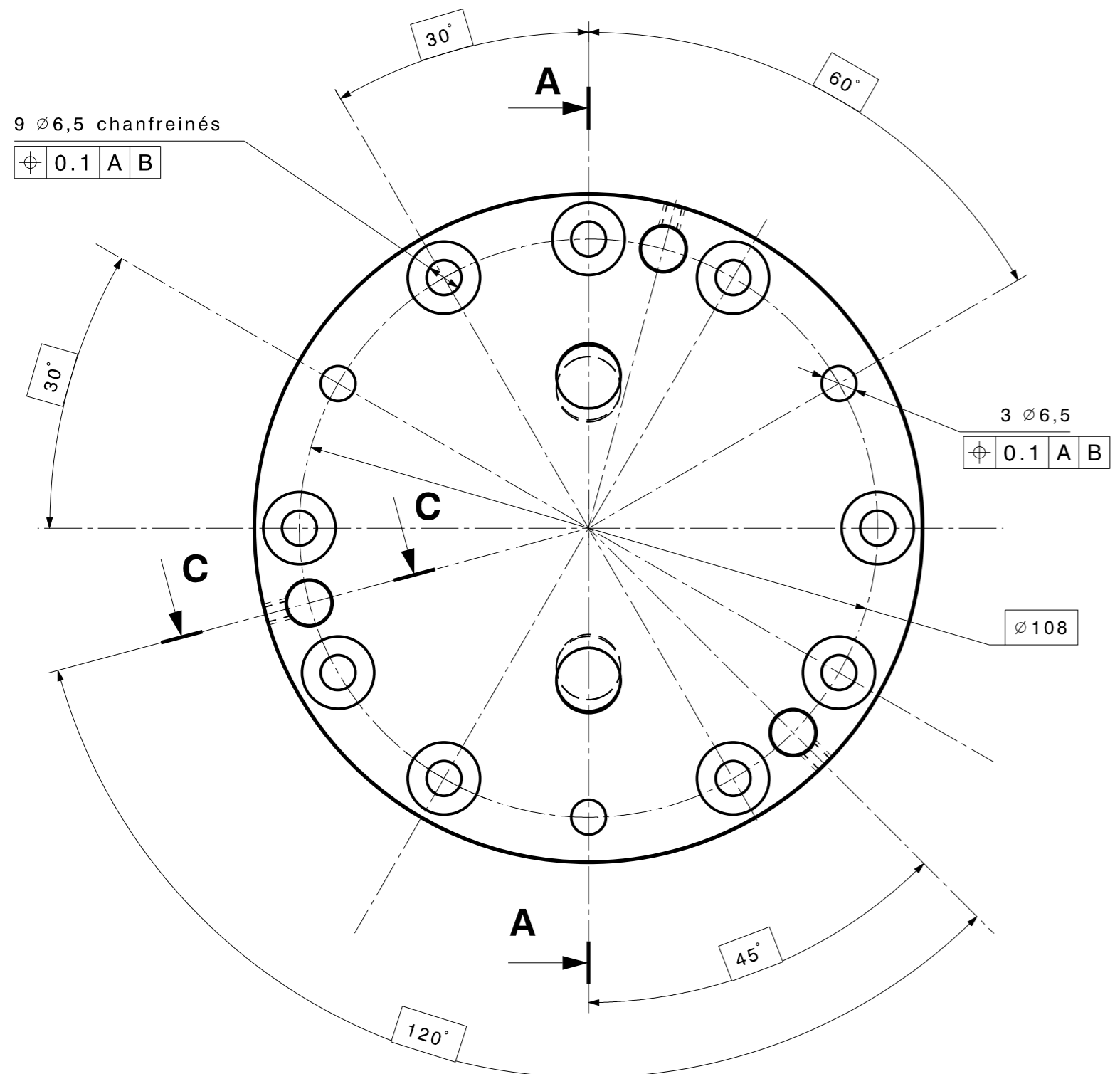
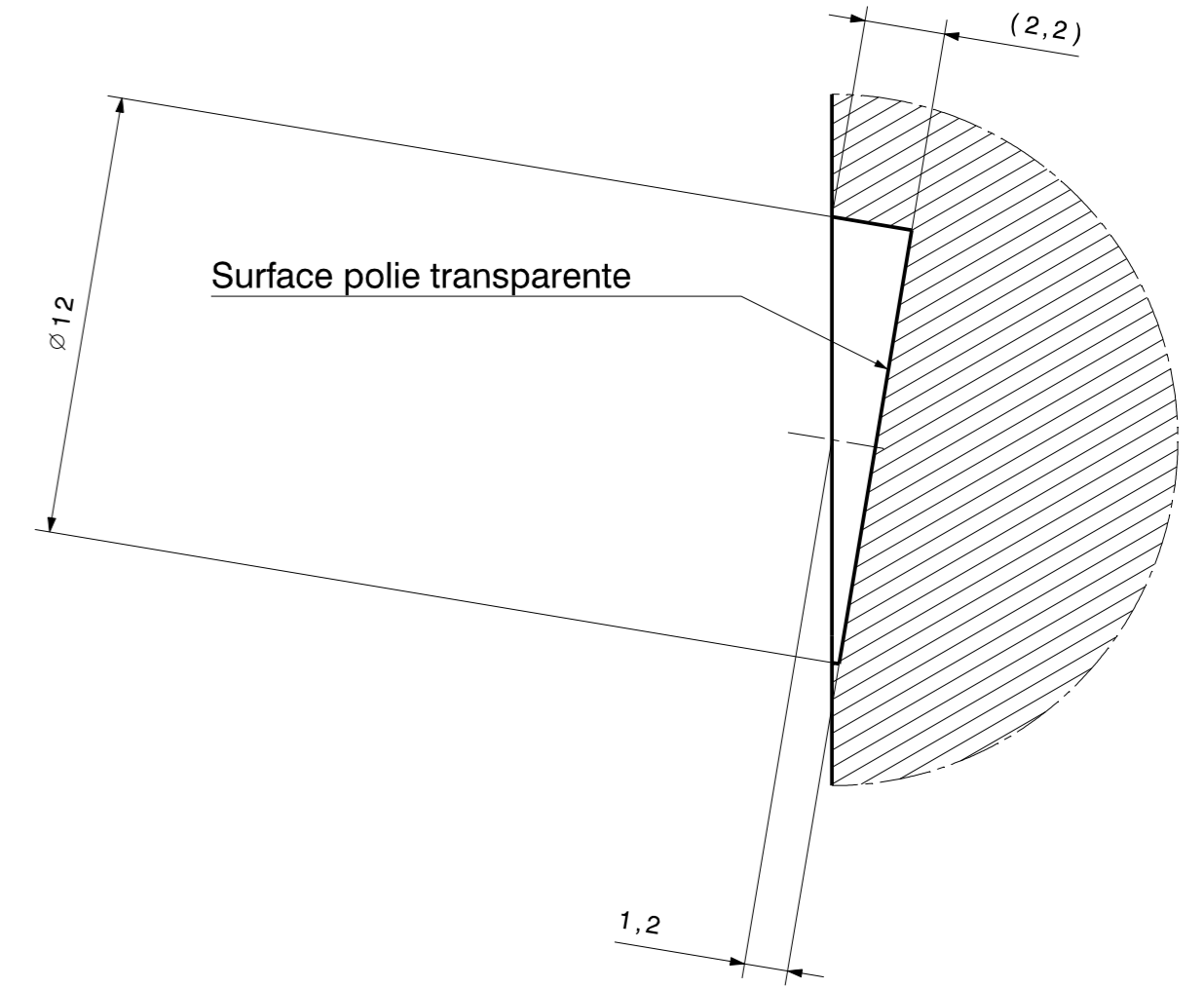

D	-	-	-	-
C	-	-	-	-
B	-	-	Edition initiale	-
Ind	Date	Dessinateur	Nature de la modification	Signature
Observation : -				
Matière : PMMA - Plaque ép. 15mm		Etat de surface : Ra = 1,6		Tolérances générales d'usinage (sauf indications contraires)
Traitements : -		Sauf indication : 4 Surfaces polies transparentes		ISO 2768 - fH
Protection : -				Rayon d'outil : R = 0,2 Maxi
Dessinateur : riveaultf		Date : 22/06/2016	Signature :	Température de référence 20°C
COUVERCLE PMMA à 2 visées				
ZUBAREV - Site STC				
Echelle	Format	Planche		
1:1	A2	1/1		
STEX/LIME				
LPE 1117- CEG PD- K 0241 317 A -				