

Rev	Description	Date	Drawn	Checked
A	Edition / First issue	05/04/2017	LEMAIRE	GIARD
B	Mise à jour / update	19/04/2017	LEMAIRE	GIARD
C	Mise à jour matière / Update material	18/05/2017	LEMAIRE	GIARD

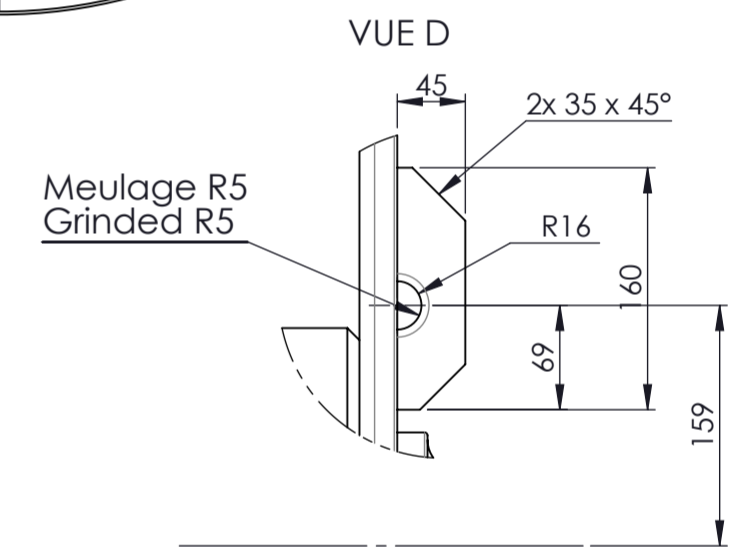
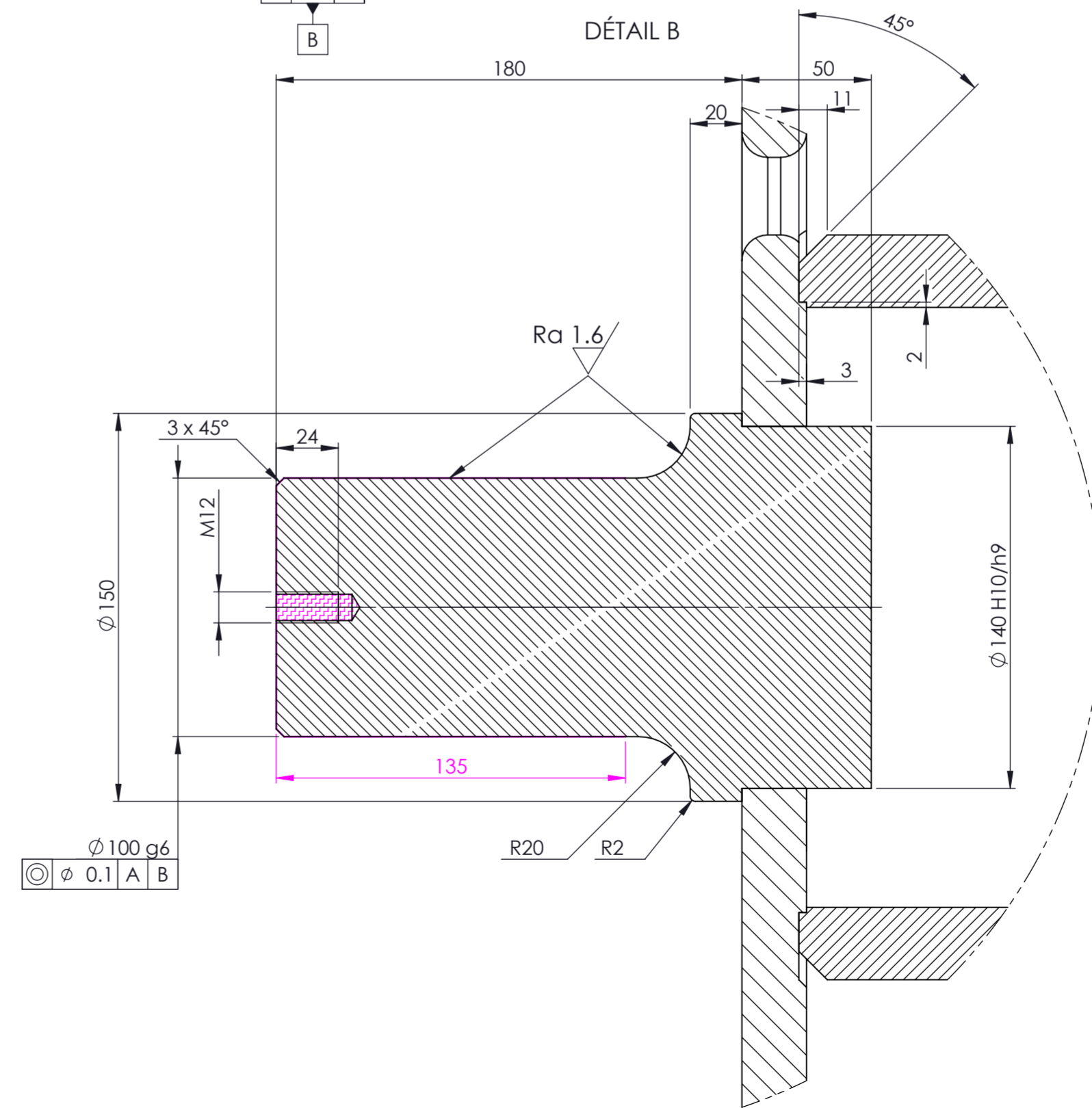
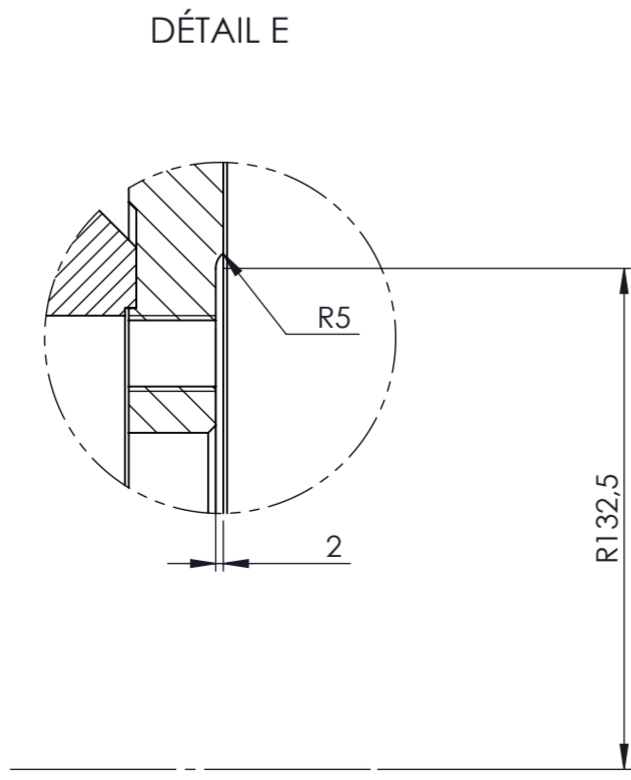
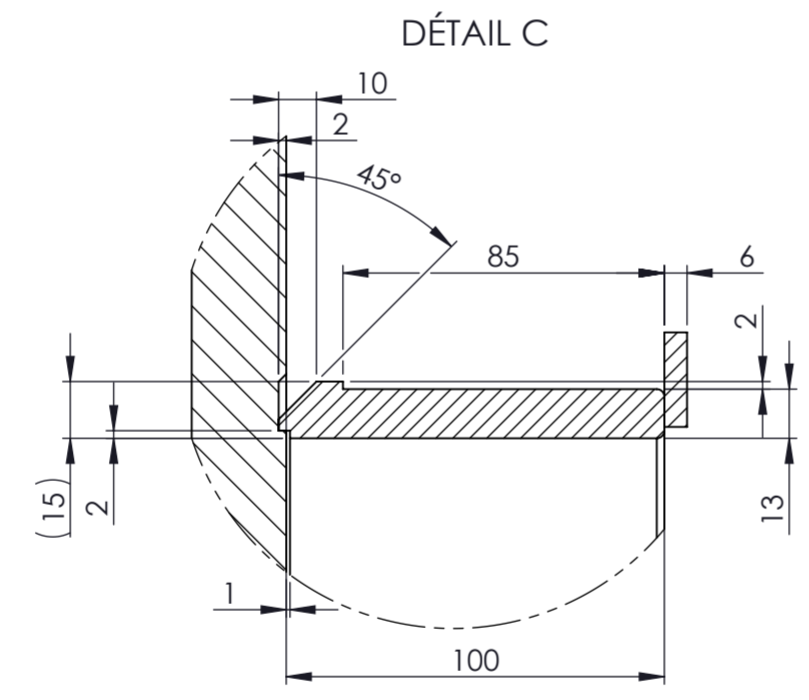
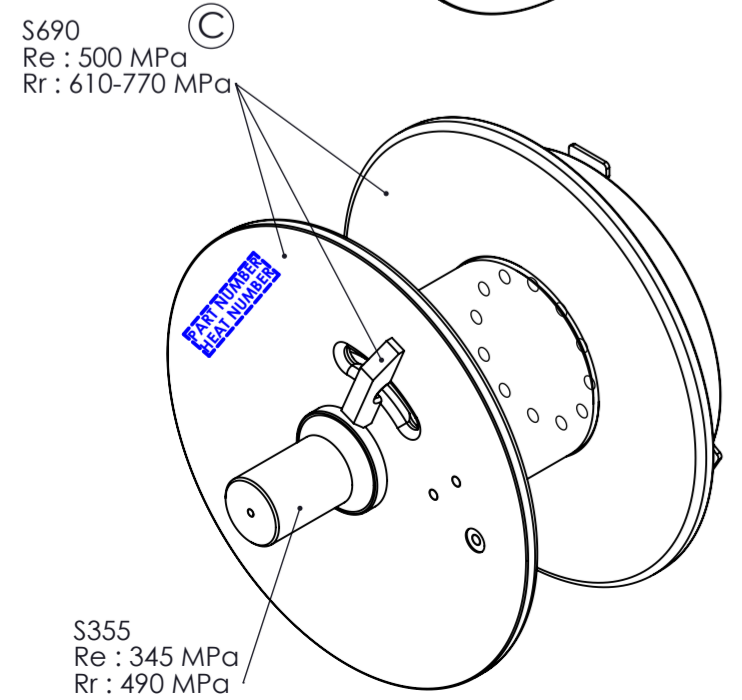
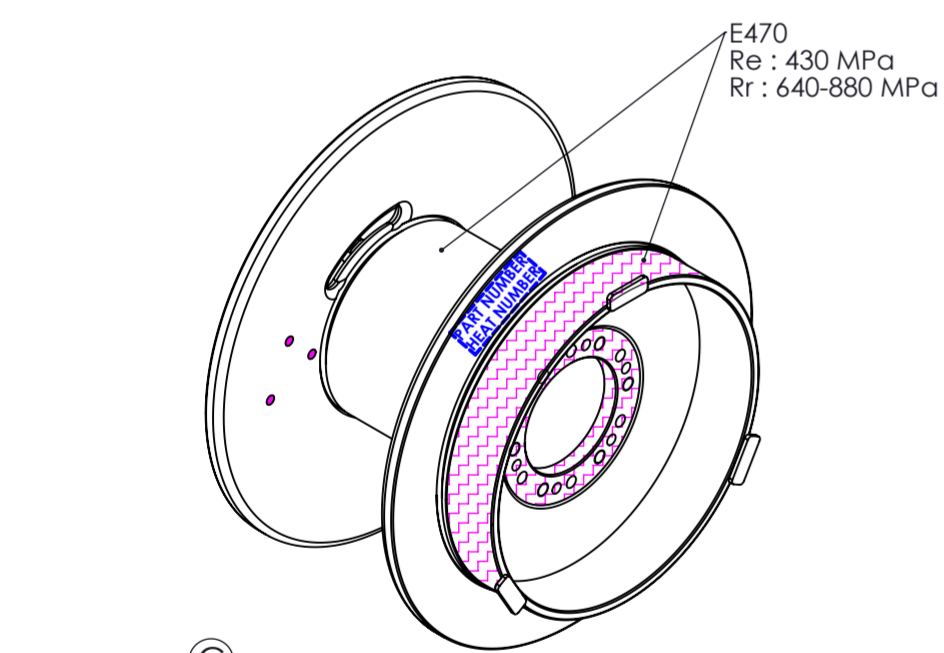
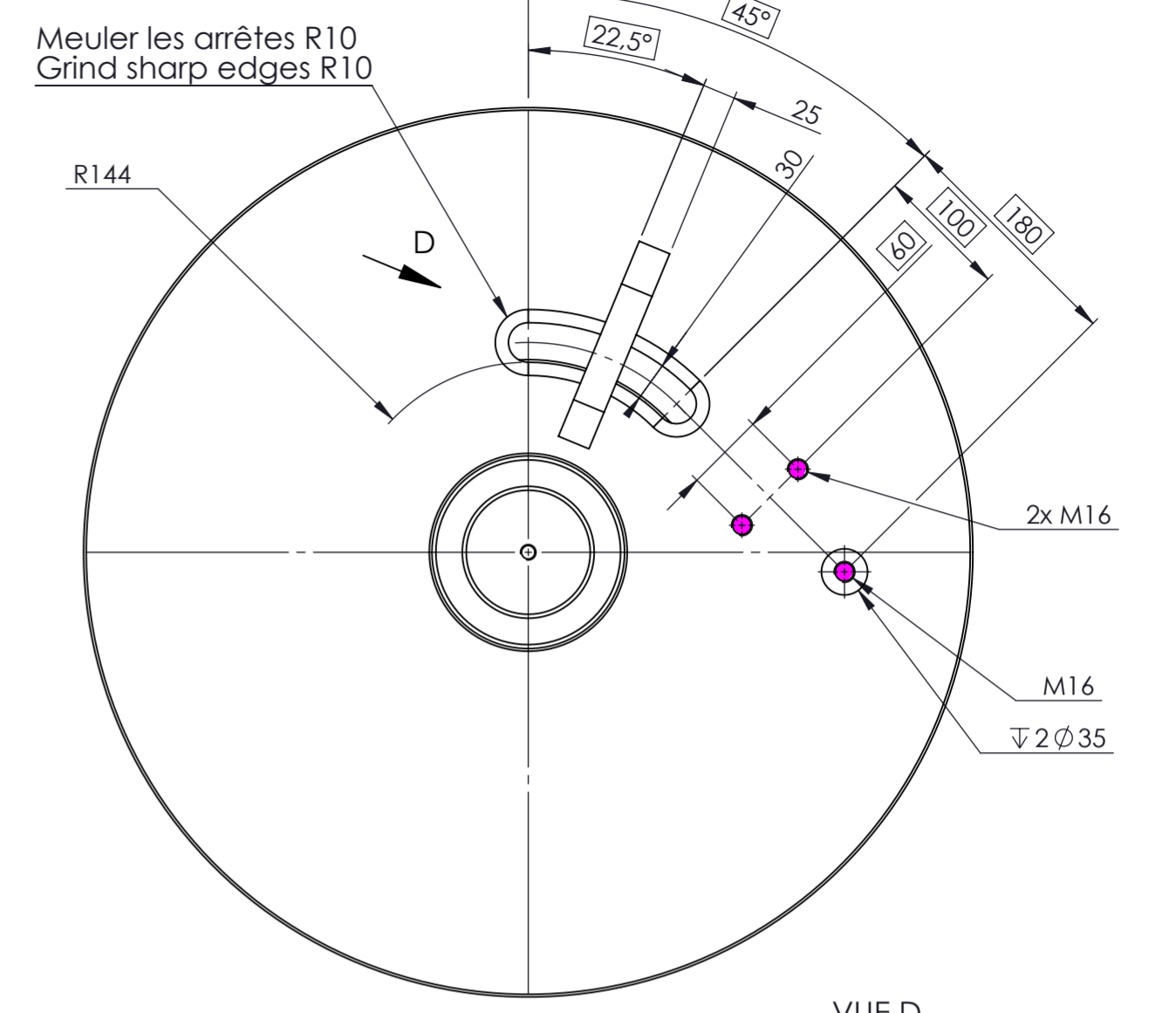
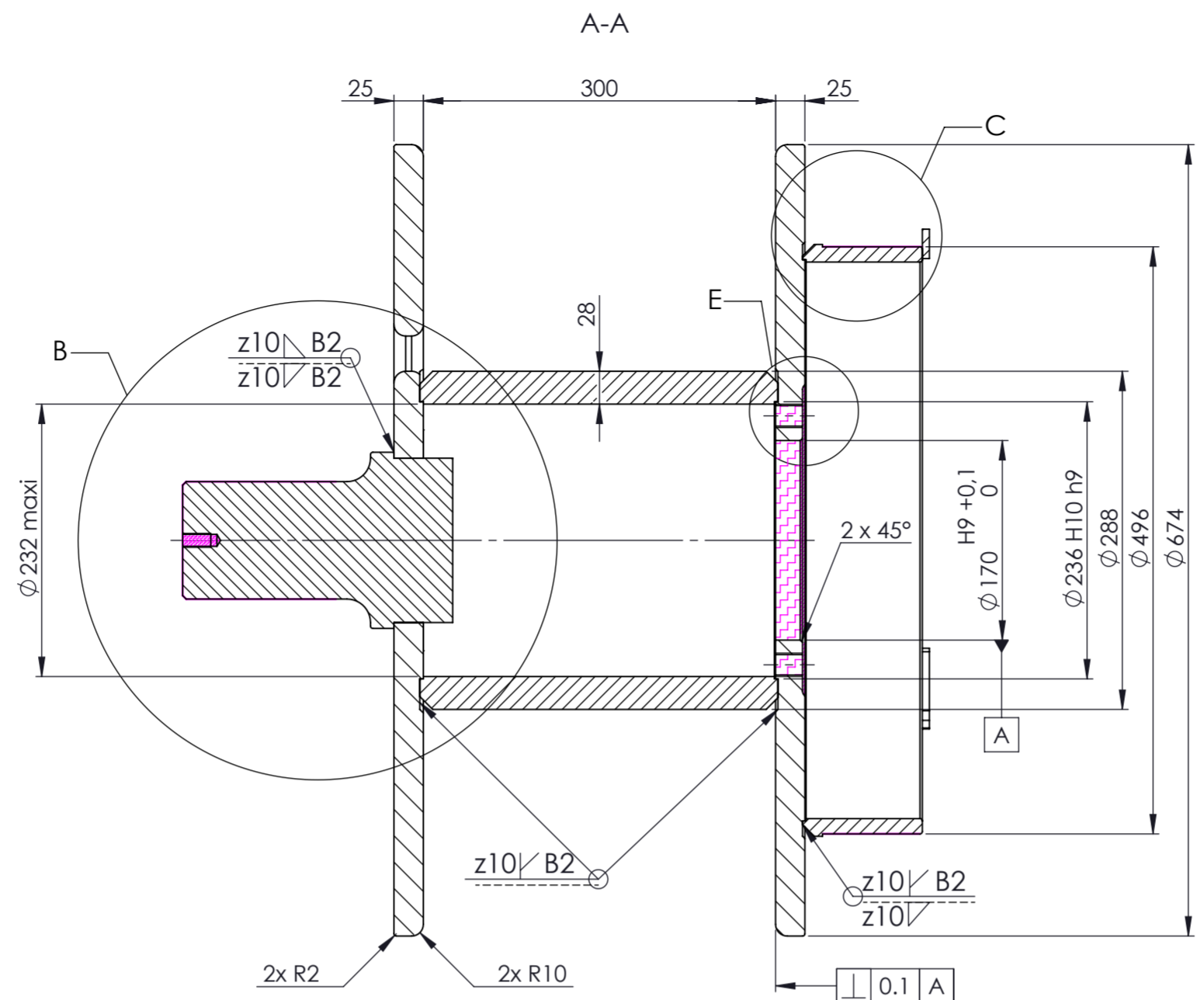
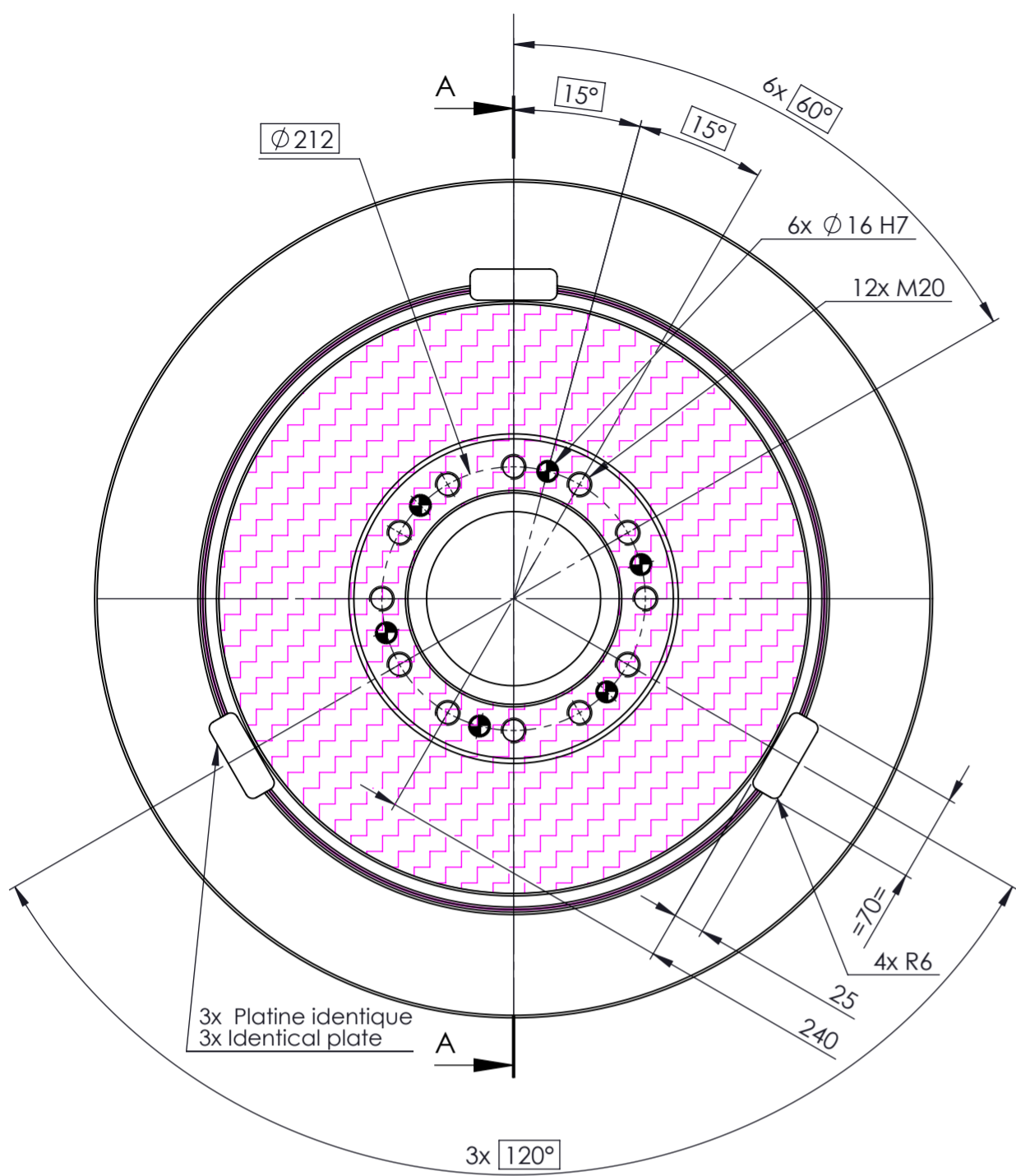

Catégories / Category	1ère / 1 st
Matière / Material	Acier - se reporter aux vues / Steel - refer to views
KVL	-
Certificat matière / Material certificate	3.1
Peinture / Painting	-
Epargnes / Surface to be saved	Se référer aux vues / Refer to view
Autre / Other	Arrêtes vives meulées R2 / Sharp edges must be grinded R2
Marquage frappé / Stamp marking	N° pièce / Part number Numéro de coulé / Heat number
Tolérance générales / General tolerances	ISO 2768 m-k
Tolérance soudure / Welding tolerance	NF E 86-050
Soudure conforme / Weld conformity	NF EN 22553, EN 1090-2 EXC2 Continuous and looped welds between all items unless otherwise specification.
CND / NDT	100% visuel / 100% visual 100% Magnétoscopie 100% Magnetic particle inspection
Poids / Weight	218 Kg

A3 1:5		Tambour soudé / Weld drum	
N° de pièce / Part number	N° plan / Drawing No	Rev	
-	1817.11.101	C	