

REV	DESCRIPTION	DATE	APPROVED
A	Increase overall length with 9mm change front radius to taper 9 degrees	2010/12/07	KL
B	Dia 1.6 added	8/31/2012	J.D.

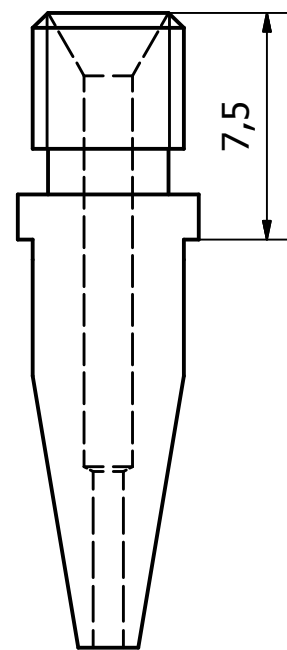
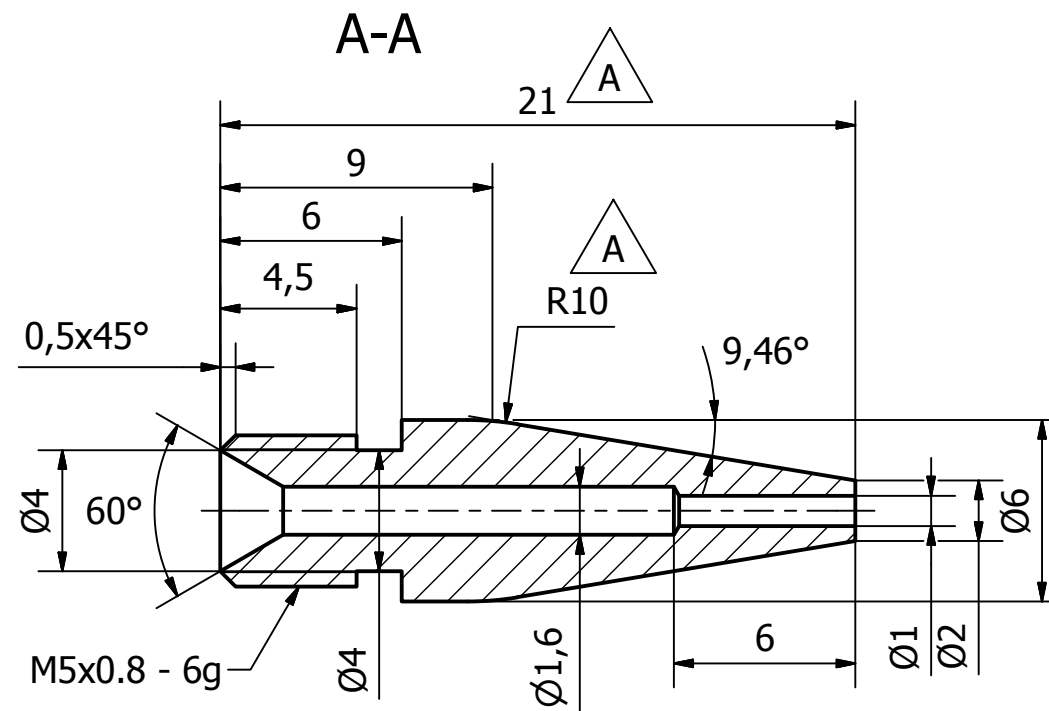
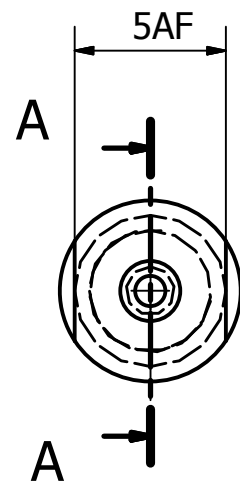

Name: Nozzle		Zeichnung Nr. 00-016-00		Rev.B		MACTEC Maschinenbau GmbH				
Matl.: Brass, Soft Yellow		Matl. Beschreibung: Rd. 6 Mosadz				E-Mail : info@mactec-maschinenbau.de				
KANTEN GEBROCHEN ± 0.3		Nicht skaliert		A3		J. Dian.	26/05/2004			
QTY.						Bearb.	Datum	Gepr.	Datum	Rev.