

ROZVINUTÝ TVAR (M 1:5)

Rozvinutá tvar odladit tak, aby byly dodrženy rozměry po ohybu

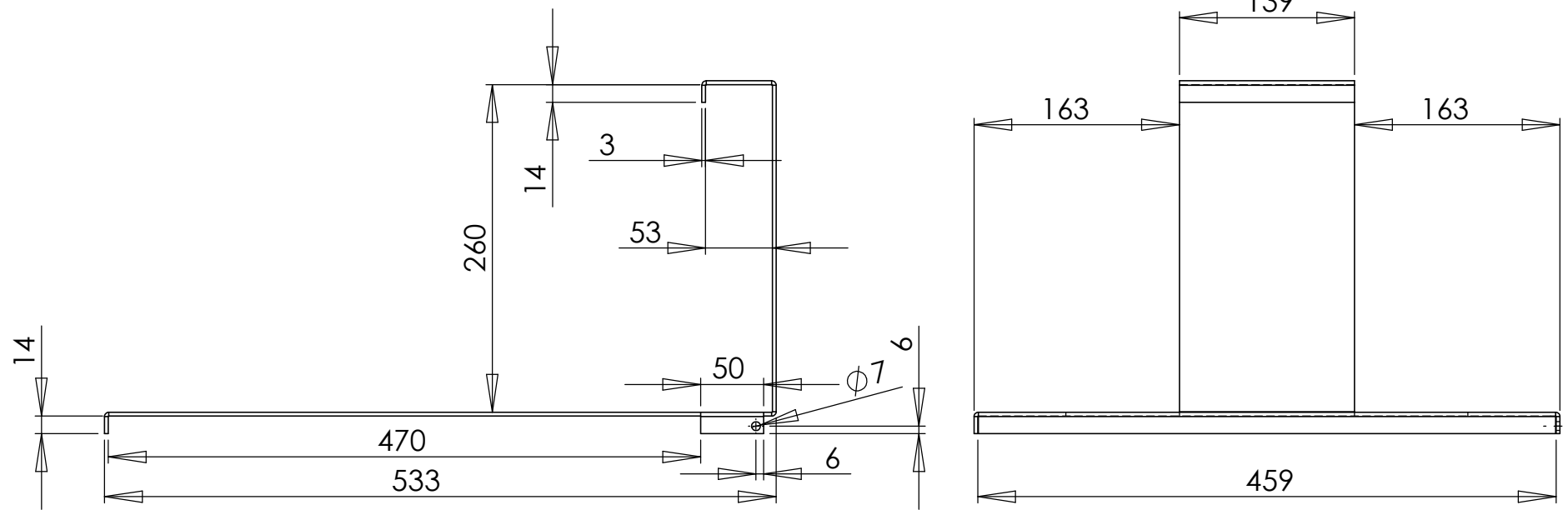
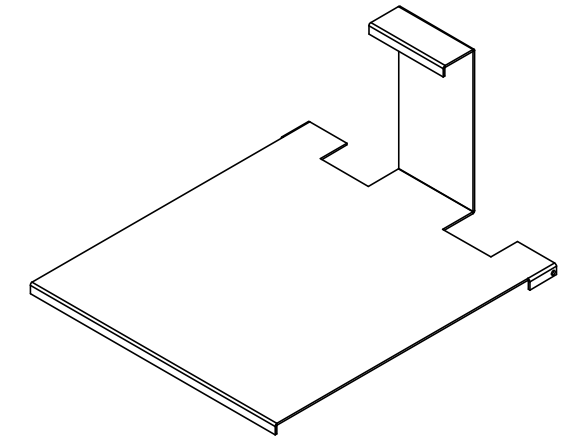
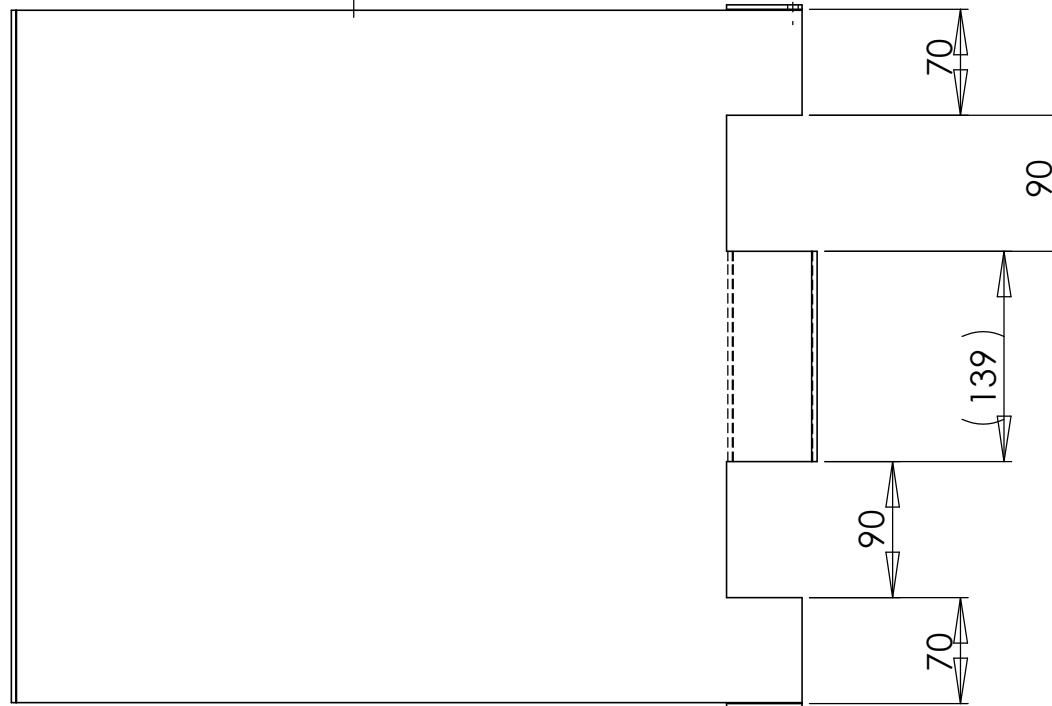
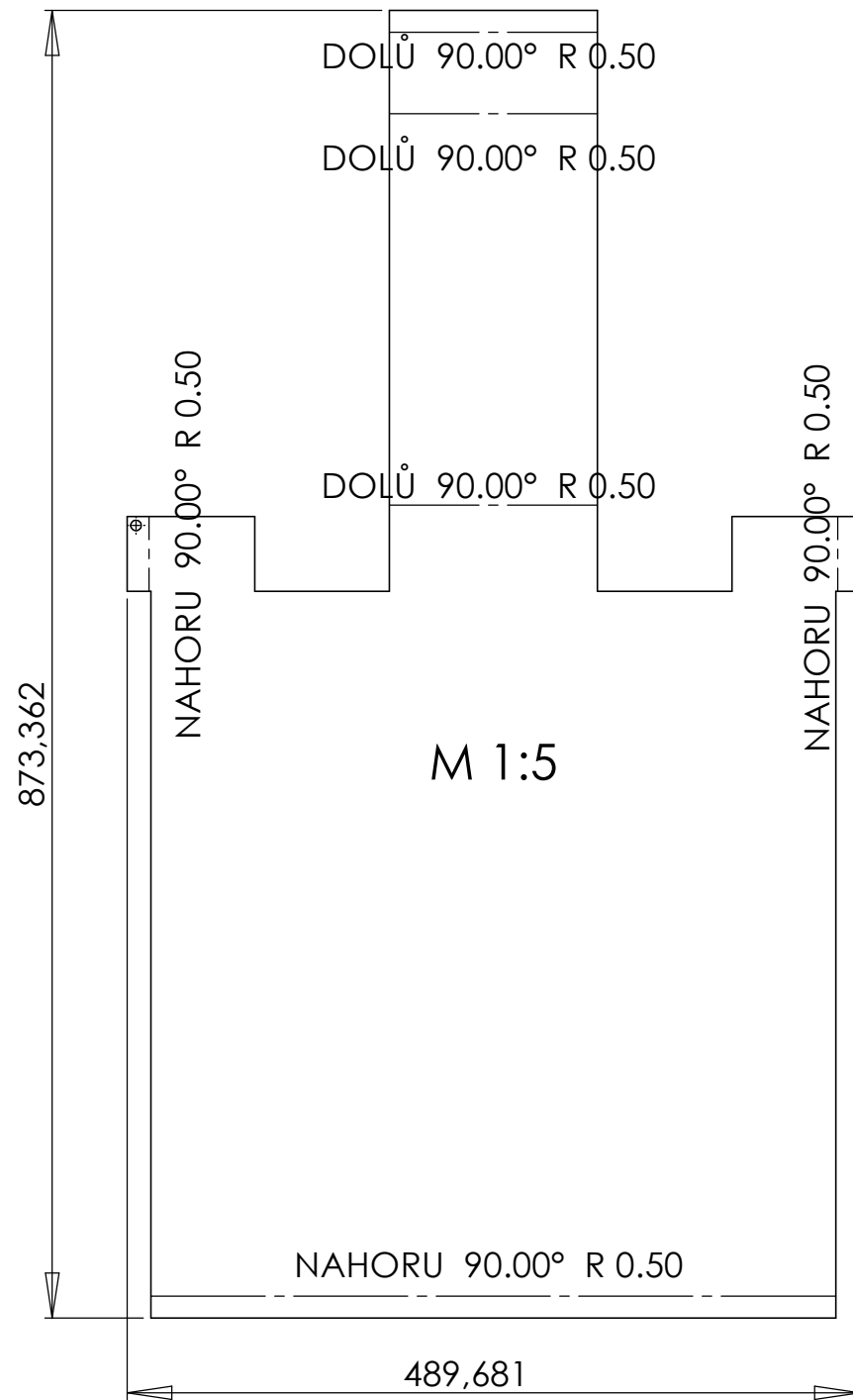

Polotovár: plech síla 3 mm, materiál S235

Rádus ohybu $R = 0,5$ mm

Lakováno barvou RAL 5017, hladká, výrobce JOTUN, označení barvy 1026674 PX20.

Tolerance netolerovaných rozměrů dle ISO 2768-mK

UNLESS OTHERWISE SPECIFIED: DIMENSIONS ARE IN MILLIMETERS		FINISH:		DEBUR AND BREAK SHARP EDGES		DO NOT SCALE DRAWING		REVISION	
SURFACE FINISH:									
TOLERANCES:									
LINEAR:									
ANGULAR:									
DRAWN		NAME	SIGNATURE	DATE			TITLE:		
CHK'D							Ocelový zásobník		
APPV'D									
MFG							DWG NO.		
Q.A					MATERIAL:		Airco - LIFT		
					WEIGHT:		SCALE:1:5		
							SHEET 1 OF 1		
							A3		