

SECTION A<sub>1</sub>-A<sub>1</sub>  
SCALE 1:1

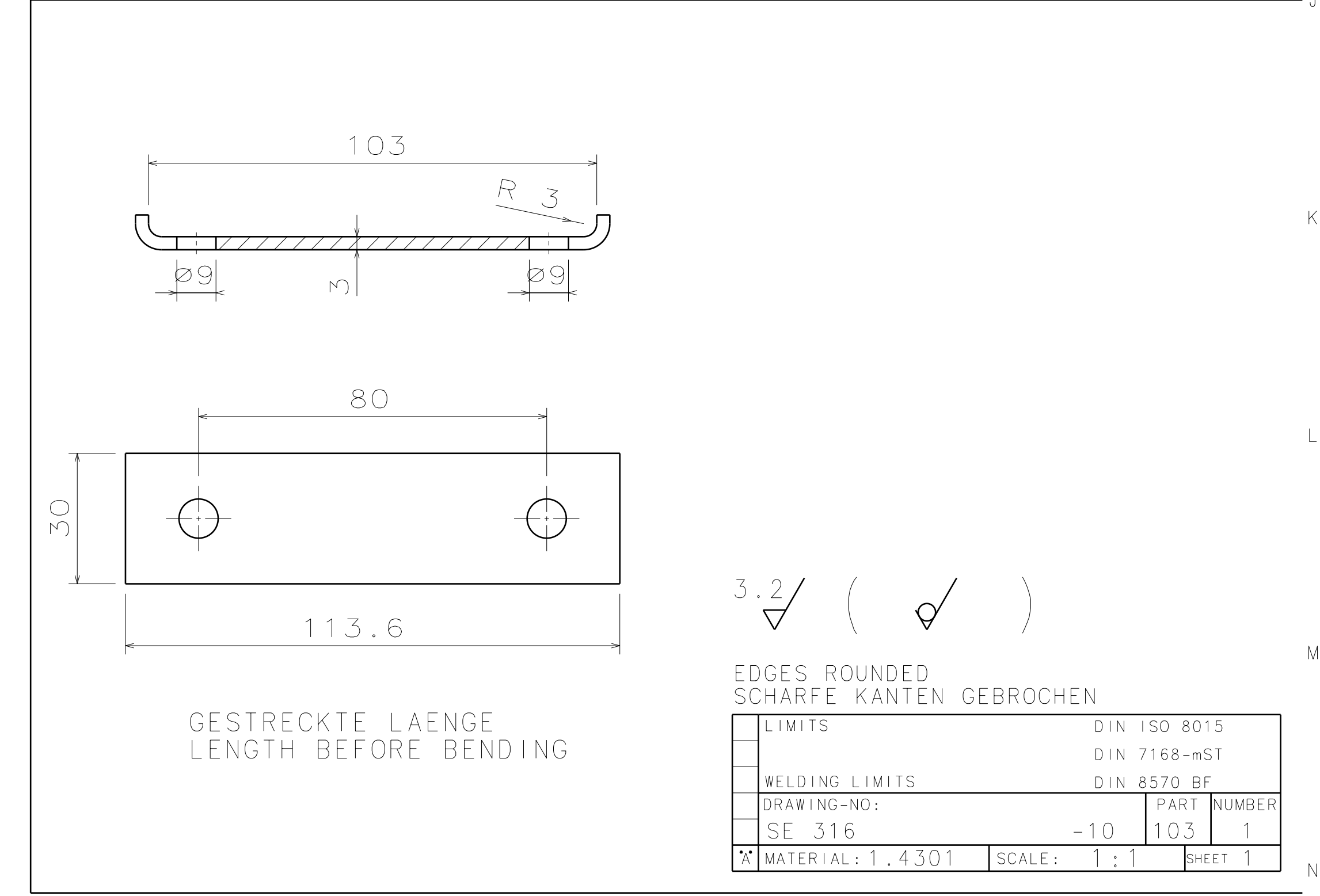
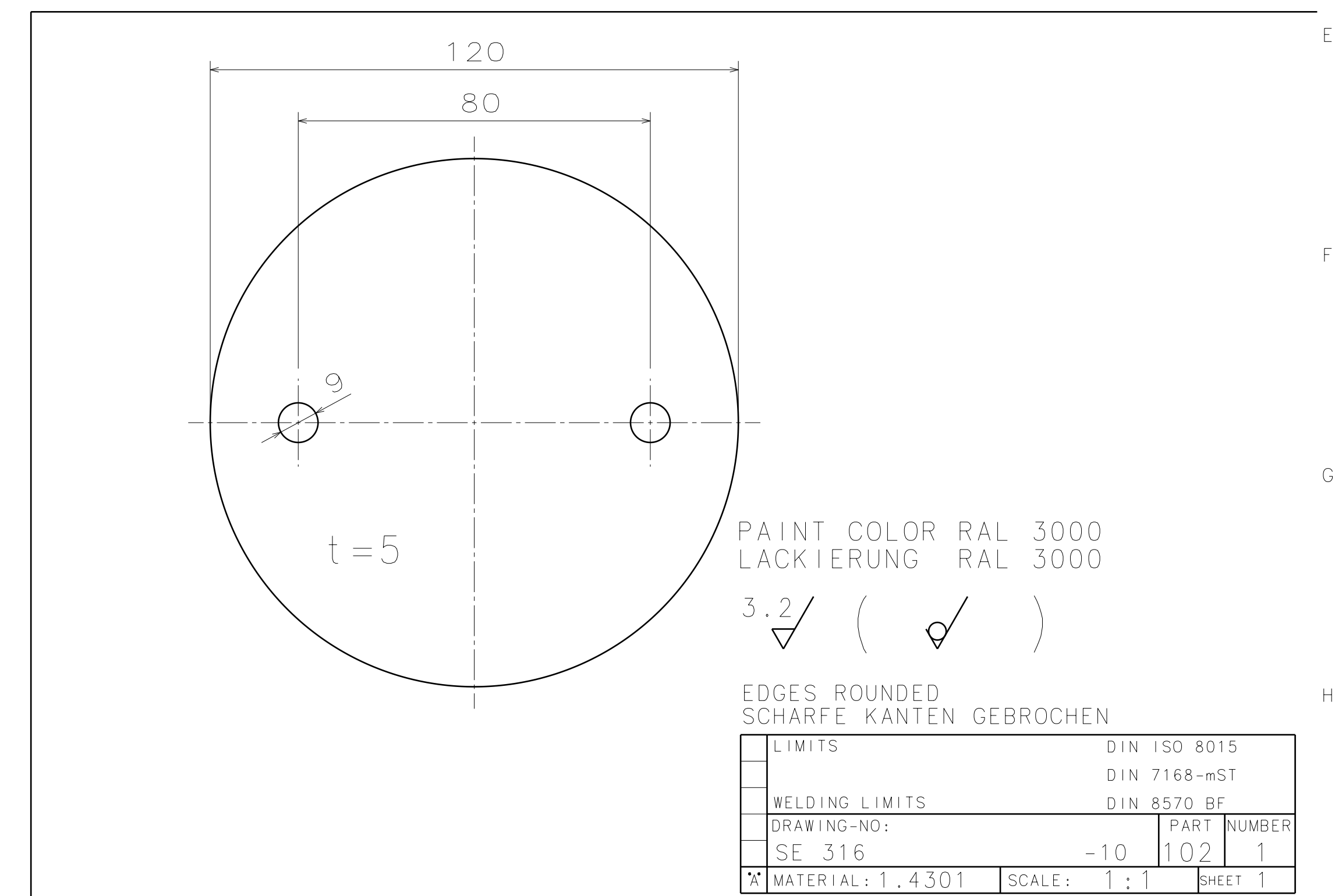
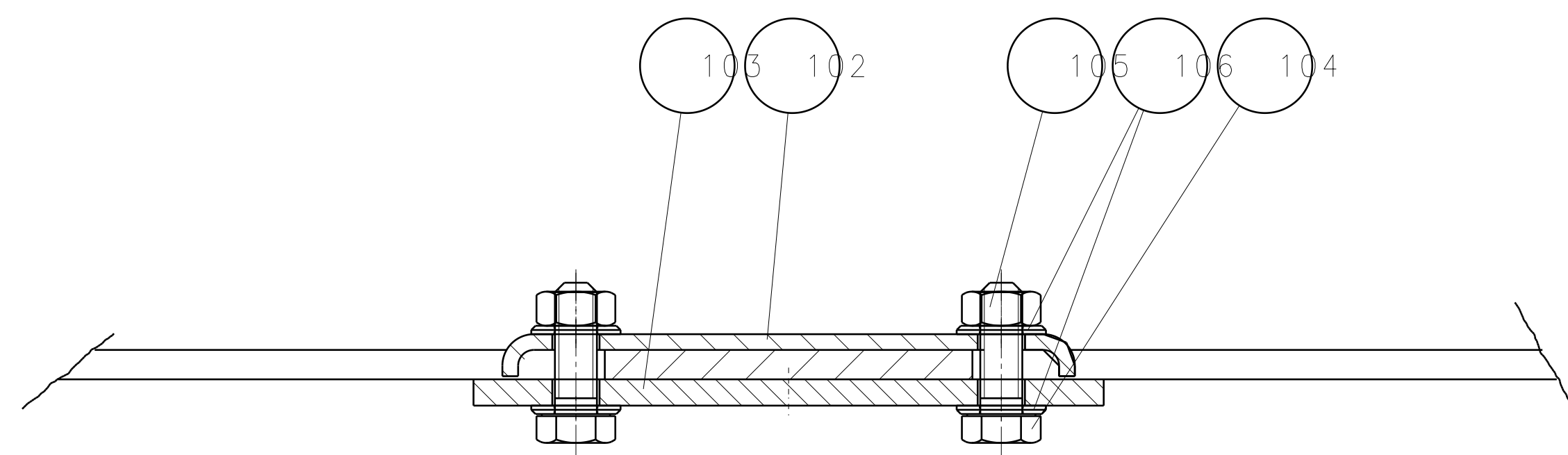

106	2	DIN125-B8.4-A2	WASHER		STAINLESS
105	2	DIN985-M8-A2	NUT		STAINLESS
104	2	DIN7991-M8x25-A2	BOLT		STAINLESS
103	1	EN10029-A3-1.4301	PLATE	110x20	STAINLESS
102	1	EN10029-A5-1.4301	PLATE	ø120	STAINLESS
101	2	CONSISTS OF 102-106			

ZECHE	27.06.95	A300-600ST	DIN 7168	D1081
STANDART BASEMENT JIG DATUM				1:1
SE - 316				-10 01/01