

N8 / (N6)

Material:
 Antreibbare Muttereinheit AME
 Mutter: R25-05T4-AME
 Maße: 25-R 5-187,0-0,0-20,0 gewirbelt

Bez.	Änderung und Ergänzung		Tag	Name	Gepr.
				POR	
	Tag	Name	Mat.:		
Gez.	05.12.2015	por			
Gepr.					
Nam gepr.					
Maßstab	1:2		Rand-Roller-Coater 4000 x 2300		
Freimaß-toleranzen DIN 7168 fein	Baugruppe: Auftragwalze-gesamt Pos.20, Hiwin-Spindel		Z.Nr.: 246_200_020 EDV Nr. A0511		
			Ersatz für:		
			Ersetzt durch:		Format A3

01019620

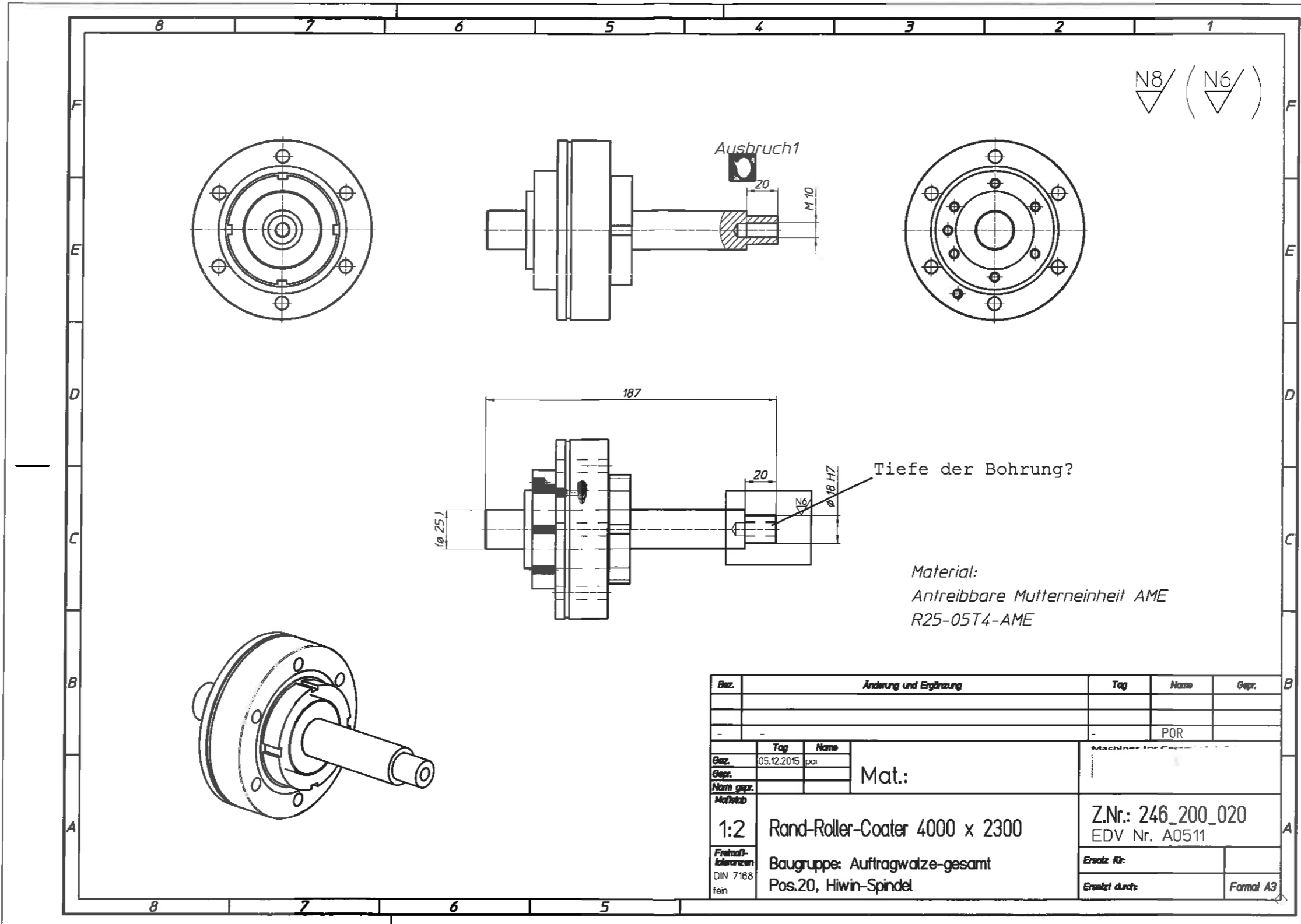

Material:
 Antreibbare Mutterneinheit AME
 R25-05T4-AME

Bez.	Änderung und Ergänzung		Tag	Name	Gepr.
				POR	
Gez.	05.12.2015	por	Mat.:		
Gepr.					
Norm gepr.					
Maßstab	1:2		Rand-Roller-Coater 4000 x 2300		Z.Nr.: 246_200_020
Freimaß- toleranzen DIN 7168 fein			Baugruppe: Auftragwalze-gesamt Pos.20, Hiwin-Spindel		EDV Nr. A0511
			Ersatz Nr.:		
			Ersatz durch:		Format A3

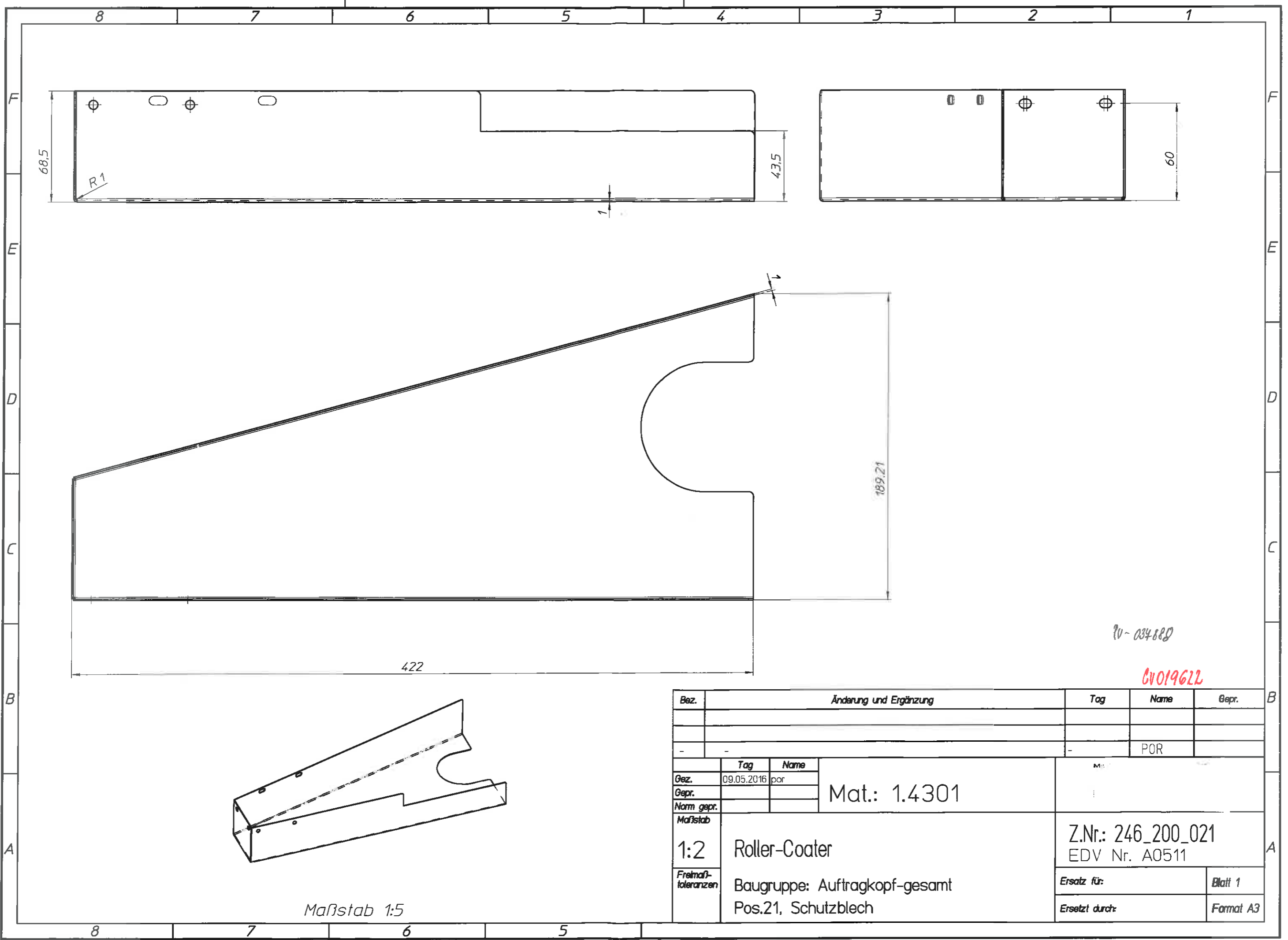

TV-03488D

CV019622

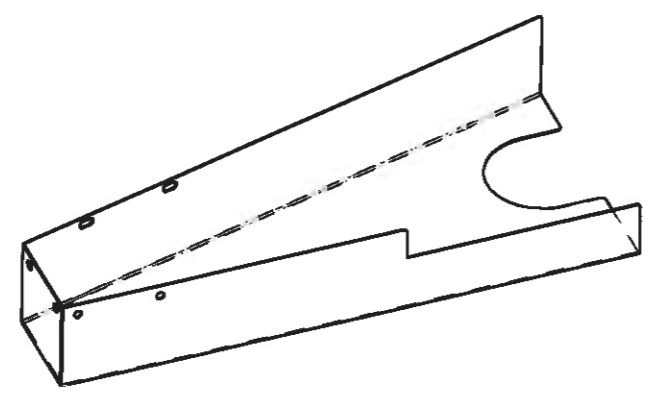

Maßstab 1:5

Bez.	Änderung und Ergänzung		Tag	Name	Gepr.
				POR	
Gez.	09.05.2016	par	Mat.: 1.4301		Z.Nr.: 246_200_021 EDV Nr. A0511
Gepr.					
Norm gepr.					
Maßstab	1:2		Roller-Coater		Ersatz für: Blatt 1
Freimaß-toleranzen			Baugruppe: Auftragkopf-gesamt Pos.21, Schutzblech		
					Ersetzt durch: Format A3

4	3	2	1																																																																																																																																																																																
D		C																																																																																																																																																																																	
<p>Material: Zahnriemenrad 36 AT5/60 Werkstoff: Al, Ausf. 6</p>																																																																																																																																																																																			
<p>2019618</p>																																																																																																																																																																																			
<table border="1" style="width:100%; border-collapse: collapse;"> <tr> <th style="width: 10%;">Bez.</th> <th style="width: 40%;">Änderung und Ergänzung</th> <th style="width: 10%;">Tag</th> <th style="width: 10%;">Name</th> <th style="width: 10%;">Gepr.</th> </tr> <tr> <td> </td> <td> </td> <td> </td> <td> </td> <td> </td> </tr> <tr> <td> </td> <td> </td> <td> </td> <td> </td> <td> </td> </tr> <tr> <td> </td> <td> </td> <td> </td> <td> </td> <td> </td> </tr> <tr> <td> </td> <td> </td> <td> </td> <td> </td> <td> </td> </tr> <tr> <td colspan="5" style="text-align: center;"> <table border="1" style="width:100%; border-collapse: collapse;"> <tr> <th style="width: 10%;">Tag</th> <th style="width: 10%;">Name</th> </tr> <tr> <td> </td> <td> </td> </tr> <tr> <td> </td> <td> </td> </tr> <tr> <td colspan="2" style="text-align: center;"> Machines for... </td> </tr> <tr> <td> </td> <td> </td> </tr> <tr> <td> </td> <td> </td> </tr> <tr> <td colspan="2" style="text-align: center;"> Mat.: </td> </tr> <tr> <td> </td> <td> </td> </tr> <tr> <td> </td> <td> </td> </tr> <tr> <td> </td> <td> </td> </tr> <tr> <td> </td> <td> </td> </tr> <tr> <td> </td> <td> </td> </tr> <tr> <td colspan="2" style="text-align: center;"> Z.Nr.: 246_200_018 EDV Nr. A0511 </td> </tr> <tr> <td colspan="2" style="text-align: center;"> Ersatz für: </td> </tr> <tr> <td colspan="2" style="text-align: center;"> Ersetzt durch: </td> </tr> <tr> <td colspan="2" style="text-align: center;"> Format A4 </td> </tr> </table> </td> </tr> <tr> <td colspan="4" style="text-align: center;"> <table border="1" style="width:100%; border-collapse: collapse;"> <tr> <th style="width: 10%;">Bez.</th> <th style="width: 10%;">Tag</th> <th style="width: 10%;">Name</th> </tr> <tr> <td> </td> <td> </td> <td> </td> </tr> <tr> <td> </td> <td> </td> <td> </td> </tr> <tr> <td> </td> <td> </td> <td> </td> </tr> <tr> <td> </td> <td> </td> <td> </td> </tr> <tr> <td colspan="3" style="text-align: center;"> Mat.: </td> </tr> <tr> <td> </td> <td> </td> <td> </td> </tr> <tr> <td> </td> <td> </td> <td> </td> </tr> <tr> <td> </td> <td> </td> <td> </td> </tr> <tr> <td> </td> <td> </td> <td> </td> </tr> <tr> <td colspan="3" style="text-align: center;"> Z.Nr.: 246_200_018 EDV Nr. A0511 </td> </tr> <tr> <td colspan="3" style="text-align: center;"> Ersatz für: </td> </tr> <tr> <td colspan="3" style="text-align: center;"> Ersetzt durch: </td> </tr> <tr> <td colspan="3" style="text-align: center;"> Format A4 </td> </tr> </table> </td> </tr> <tr> <td colspan="4" style="text-align: center;"> <table border="1" style="width:100%; border-collapse: collapse;"> <tr> <th style="width: 10%;">Freimaß- toleranzen</th> <th style="width: 10%;">DIN 7168</th> <th style="width: 10%;">fein</th> </tr> <tr> <td> </td> <td> </td> <td> </td> </tr> <tr> <td> </td> <td> </td> <td> </td> </tr> <tr> <td colspan="3" style="text-align: center;"> 1:2 </td> </tr> <tr> <td colspan="3" style="text-align: center;"> Rand-Roller-Coater 4000 x 2300 </td> </tr> <tr> <td colspan="3" style="text-align: center;"> Baugruppe: Auftragkopf-gesamt </td> </tr> <tr> <td colspan="3" style="text-align: center;"> Pos.18, Synchronscheibe-1 </td> </tr> </table> </td> </tr> <tr> <td colspan="4" style="text-align: center;"> <table border="1" style="width:100%; border-collapse: collapse;"> <tr> <th style="width: 10%;">Bez.</th> <th style="width: 10%;">Tag</th> <th style="width: 10%;">Name</th> </tr> <tr> <td> </td> <td> </td> <td> </td> </tr> <tr> <td> </td> <td> </td> <td> </td> </tr> <tr> <td> </td> <td> </td> <td> </td> </tr> <tr> <td> </td> <td> </td> <td> </td> </tr> <tr> <td colspan="3" style="text-align: center;"> Mat.: </td> </tr> <tr> <td> </td> <td> </td> <td> </td> </tr> <tr> <td> </td> <td> </td> <td> </td> </tr> <tr> <td> </td> <td> </td> <td> </td> </tr> <tr> <td colspan="3" style="text-align: center;"> Z.Nr.: 246_200_018 EDV Nr. A0511 </td> </tr> <tr> <td colspan="3" style="text-align: center;"> Ersatz für: </td> </tr> <tr> <td colspan="3" style="text-align: center;"> Ersetzt durch: </td> </tr> <tr> <td colspan="3" style="text-align: center;"> Format A4 </td> </tr> </table> </td> </tr> </table>				Bez.	Änderung und Ergänzung	Tag	Name	Gepr.																					<table border="1" style="width:100%; border-collapse: collapse;"> <tr> <th style="width: 10%;">Tag</th> <th style="width: 10%;">Name</th> </tr> <tr> <td> </td> <td> </td> </tr> <tr> <td> </td> <td> </td> </tr> <tr> <td colspan="2" style="text-align: center;"> Machines for... </td> </tr> <tr> <td> </td> <td> </td> </tr> <tr> <td> </td> <td> </td> </tr> <tr> <td colspan="2" style="text-align: center;"> Mat.: </td> </tr> <tr> <td> </td> <td> </td> </tr> <tr> <td> </td> <td> </td> </tr> <tr> <td> </td> <td> </td> </tr> <tr> <td> </td> <td> </td> </tr> <tr> <td> </td> <td> </td> </tr> <tr> <td colspan="2" style="text-align: center;"> Z.Nr.: 246_200_018 EDV Nr. A0511 </td> </tr> <tr> <td colspan="2" style="text-align: center;"> Ersatz für: </td> </tr> <tr> <td colspan="2" style="text-align: center;"> Ersetzt durch: </td> </tr> <tr> <td colspan="2" style="text-align: center;"> Format A4 </td> </tr> </table>					Tag	Name					Machines for...						Mat.:												Z.Nr.: 246_200_018 EDV Nr. A0511		Ersatz für:		Ersetzt durch:		Format A4		<table border="1" style="width:100%; border-collapse: collapse;"> <tr> <th style="width: 10%;">Bez.</th> <th style="width: 10%;">Tag</th> <th style="width: 10%;">Name</th> </tr> <tr> <td> </td> <td> </td> <td> </td> </tr> <tr> <td> </td> <td> </td> <td> </td> </tr> <tr> <td> </td> <td> </td> <td> </td> </tr> <tr> <td> </td> <td> </td> <td> </td> </tr> <tr> <td colspan="3" style="text-align: center;"> Mat.: </td> </tr> <tr> <td> </td> <td> </td> <td> </td> </tr> <tr> <td> </td> <td> </td> <td> </td> </tr> <tr> <td> </td> <td> </td> <td> </td> </tr> <tr> <td> </td> <td> </td> <td> </td> </tr> <tr> <td colspan="3" style="text-align: center;"> Z.Nr.: 246_200_018 EDV Nr. A0511 </td> </tr> <tr> <td colspan="3" style="text-align: center;"> Ersatz für: </td> </tr> <tr> <td colspan="3" style="text-align: center;"> Ersetzt durch: </td> </tr> <tr> <td colspan="3" style="text-align: center;"> Format A4 </td> </tr> </table>				Bez.	Tag	Name													Mat.:															Z.Nr.: 246_200_018 EDV Nr. A0511			Ersatz für:			Ersetzt durch:			Format A4			<table border="1" style="width:100%; border-collapse: collapse;"> <tr> <th style="width: 10%;">Freimaß- toleranzen</th> <th style="width: 10%;">DIN 7168</th> <th style="width: 10%;">fein</th> </tr> <tr> <td> </td> <td> </td> <td> </td> </tr> <tr> <td> </td> <td> </td> <td> </td> </tr> <tr> <td colspan="3" style="text-align: center;"> 1:2 </td> </tr> <tr> <td colspan="3" style="text-align: center;"> Rand-Roller-Coater 4000 x 2300 </td> </tr> <tr> <td colspan="3" style="text-align: center;"> Baugruppe: Auftragkopf-gesamt </td> </tr> <tr> <td colspan="3" style="text-align: center;"> Pos.18, Synchronscheibe-1 </td> </tr> </table>				Freimaß- toleranzen	DIN 7168	fein							1:2			Rand-Roller-Coater 4000 x 2300			Baugruppe: Auftragkopf-gesamt			Pos.18, Synchronscheibe-1			<table border="1" style="width:100%; border-collapse: collapse;"> <tr> <th style="width: 10%;">Bez.</th> <th style="width: 10%;">Tag</th> <th style="width: 10%;">Name</th> </tr> <tr> <td> </td> <td> </td> <td> </td> </tr> <tr> <td> </td> <td> </td> <td> </td> </tr> <tr> <td> </td> <td> </td> <td> </td> </tr> <tr> <td> </td> <td> </td> <td> </td> </tr> <tr> <td colspan="3" style="text-align: center;"> Mat.: </td> </tr> <tr> <td> </td> <td> </td> <td> </td> </tr> <tr> <td> </td> <td> </td> <td> </td> </tr> <tr> <td> </td> <td> </td> <td> </td> </tr> <tr> <td colspan="3" style="text-align: center;"> Z.Nr.: 246_200_018 EDV Nr. A0511 </td> </tr> <tr> <td colspan="3" style="text-align: center;"> Ersatz für: </td> </tr> <tr> <td colspan="3" style="text-align: center;"> Ersetzt durch: </td> </tr> <tr> <td colspan="3" style="text-align: center;"> Format A4 </td> </tr> </table>				Bez.	Tag	Name													Mat.:												Z.Nr.: 246_200_018 EDV Nr. A0511			Ersatz für:			Ersetzt durch:			Format A4		
Bez.	Änderung und Ergänzung	Tag	Name	Gepr.																																																																																																																																																																															
<table border="1" style="width:100%; border-collapse: collapse;"> <tr> <th style="width: 10%;">Tag</th> <th style="width: 10%;">Name</th> </tr> <tr> <td> </td> <td> </td> </tr> <tr> <td> </td> <td> </td> </tr> <tr> <td colspan="2" style="text-align: center;"> Machines for... </td> </tr> <tr> <td> </td> <td> </td> </tr> <tr> <td> </td> <td> </td> </tr> <tr> <td colspan="2" style="text-align: center;"> Mat.: </td> </tr> <tr> <td> </td> <td> </td> </tr> <tr> <td> </td> <td> </td> </tr> <tr> <td> </td> <td> </td> </tr> <tr> <td> </td> <td> </td> </tr> <tr> <td> </td> <td> </td> </tr> <tr> <td colspan="2" style="text-align: center;"> Z.Nr.: 246_200_018 EDV Nr. A0511 </td> </tr> <tr> <td colspan="2" style="text-align: center;"> Ersatz für: </td> </tr> <tr> <td colspan="2" style="text-align: center;"> Ersetzt durch: </td> </tr> <tr> <td colspan="2" style="text-align: center;"> Format A4 </td> </tr> </table>					Tag	Name					Machines for...						Mat.:												Z.Nr.: 246_200_018 EDV Nr. A0511		Ersatz für:		Ersetzt durch:		Format A4																																																																																																																																																
Tag	Name																																																																																																																																																																																		
Machines for...																																																																																																																																																																																			
Mat.:																																																																																																																																																																																			
Z.Nr.: 246_200_018 EDV Nr. A0511																																																																																																																																																																																			
Ersatz für:																																																																																																																																																																																			
Ersetzt durch:																																																																																																																																																																																			
Format A4																																																																																																																																																																																			
<table border="1" style="width:100%; border-collapse: collapse;"> <tr> <th style="width: 10%;">Bez.</th> <th style="width: 10%;">Tag</th> <th style="width: 10%;">Name</th> </tr> <tr> <td> </td> <td> </td> <td> </td> </tr> <tr> <td> </td> <td> </td> <td> </td> </tr> <tr> <td> </td> <td> </td> <td> </td> </tr> <tr> <td> </td> <td> </td> <td> </td> </tr> <tr> <td colspan="3" style="text-align: center;"> Mat.: </td> </tr> <tr> <td> </td> <td> </td> <td> </td> </tr> <tr> <td> </td> <td> </td> <td> </td> </tr> <tr> <td> </td> <td> </td> <td> </td> </tr> <tr> <td> </td> <td> </td> <td> </td> </tr> <tr> <td colspan="3" style="text-align: center;"> Z.Nr.: 246_200_018 EDV Nr. A0511 </td> </tr> <tr> <td colspan="3" style="text-align: center;"> Ersatz für: </td> </tr> <tr> <td colspan="3" style="text-align: center;"> Ersetzt durch: </td> </tr> <tr> <td colspan="3" style="text-align: center;"> Format A4 </td> </tr> </table>				Bez.	Tag	Name													Mat.:															Z.Nr.: 246_200_018 EDV Nr. A0511			Ersatz für:			Ersetzt durch:			Format A4																																																																																																																																								
Bez.	Tag	Name																																																																																																																																																																																	
Mat.:																																																																																																																																																																																			
Z.Nr.: 246_200_018 EDV Nr. A0511																																																																																																																																																																																			
Ersatz für:																																																																																																																																																																																			
Ersetzt durch:																																																																																																																																																																																			
Format A4																																																																																																																																																																																			
<table border="1" style="width:100%; border-collapse: collapse;"> <tr> <th style="width: 10%;">Freimaß- toleranzen</th> <th style="width: 10%;">DIN 7168</th> <th style="width: 10%;">fein</th> </tr> <tr> <td> </td> <td> </td> <td> </td> </tr> <tr> <td> </td> <td> </td> <td> </td> </tr> <tr> <td colspan="3" style="text-align: center;"> 1:2 </td> </tr> <tr> <td colspan="3" style="text-align: center;"> Rand-Roller-Coater 4000 x 2300 </td> </tr> <tr> <td colspan="3" style="text-align: center;"> Baugruppe: Auftragkopf-gesamt </td> </tr> <tr> <td colspan="3" style="text-align: center;"> Pos.18, Synchronscheibe-1 </td> </tr> </table>				Freimaß- toleranzen	DIN 7168	fein							1:2			Rand-Roller-Coater 4000 x 2300			Baugruppe: Auftragkopf-gesamt			Pos.18, Synchronscheibe-1																																																																																																																																																													
Freimaß- toleranzen	DIN 7168	fein																																																																																																																																																																																	
1:2																																																																																																																																																																																			
Rand-Roller-Coater 4000 x 2300																																																																																																																																																																																			
Baugruppe: Auftragkopf-gesamt																																																																																																																																																																																			
Pos.18, Synchronscheibe-1																																																																																																																																																																																			
<table border="1" style="width:100%; border-collapse: collapse;"> <tr> <th style="width: 10%;">Bez.</th> <th style="width: 10%;">Tag</th> <th style="width: 10%;">Name</th> </tr> <tr> <td> </td> <td> </td> <td> </td> </tr> <tr> <td> </td> <td> </td> <td> </td> </tr> <tr> <td> </td> <td> </td> <td> </td> </tr> <tr> <td> </td> <td> </td> <td> </td> </tr> <tr> <td colspan="3" style="text-align: center;"> Mat.: </td> </tr> <tr> <td> </td> <td> </td> <td> </td> </tr> <tr> <td> </td> <td> </td> <td> </td> </tr> <tr> <td> </td> <td> </td> <td> </td> </tr> <tr> <td colspan="3" style="text-align: center;"> Z.Nr.: 246_200_018 EDV Nr. A0511 </td> </tr> <tr> <td colspan="3" style="text-align: center;"> Ersatz für: </td> </tr> <tr> <td colspan="3" style="text-align: center;"> Ersetzt durch: </td> </tr> <tr> <td colspan="3" style="text-align: center;"> Format A4 </td> </tr> </table>				Bez.	Tag	Name													Mat.:												Z.Nr.: 246_200_018 EDV Nr. A0511			Ersatz für:			Ersetzt durch:			Format A4																																																																																																																																											
Bez.	Tag	Name																																																																																																																																																																																	
Mat.:																																																																																																																																																																																			
Z.Nr.: 246_200_018 EDV Nr. A0511																																																																																																																																																																																			
Ersatz für:																																																																																																																																																																																			
Ersetzt durch:																																																																																																																																																																																			
Format A4																																																																																																																																																																																			

Schnitt A-A

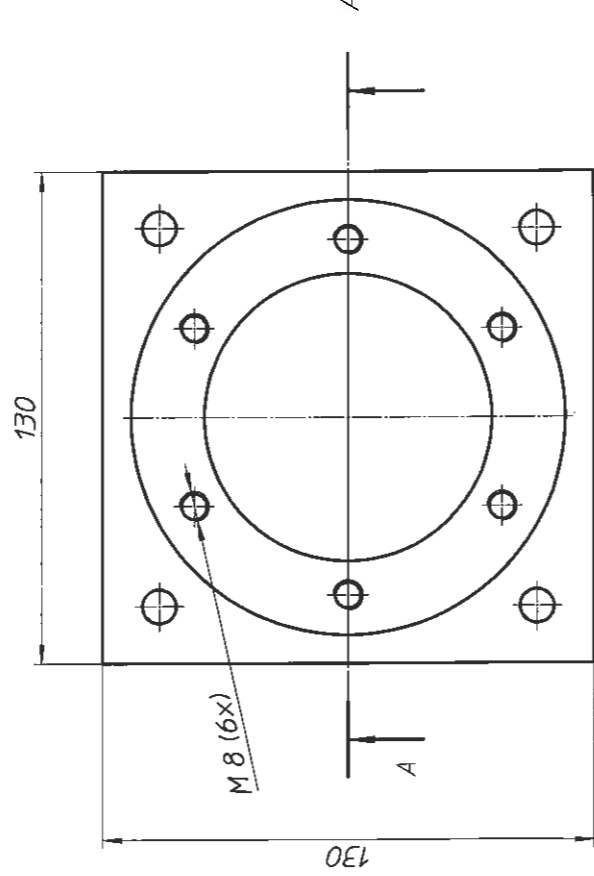

Maßstab 1:3

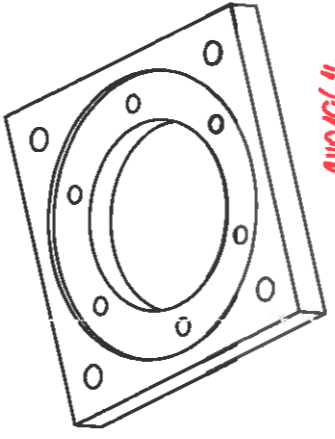

N9/

Mat.: AlMg4,5Mn

01019614

Bez.	Anderung und Ergänzung		Tag	Name	Gepr.
				POR	
	Machines für Keramik im Printing				
Gez.	Tag	Name			
Gepr.	03.12.2015	por			
Norm gepr.					
Maßstab					
1:2	Rand-Roller-Coater 4000 x 2300		Z.Nr.: 246_200_014		
Freimaß- toleranzen DIN 7168 fein	Baugruppe: Auftragswalze-gesamt		EDV Nr. A0511		
	Pos.14, Befestigungsplatte		Ersatz für:		
			Ersetzt durch:		
			Format A4		

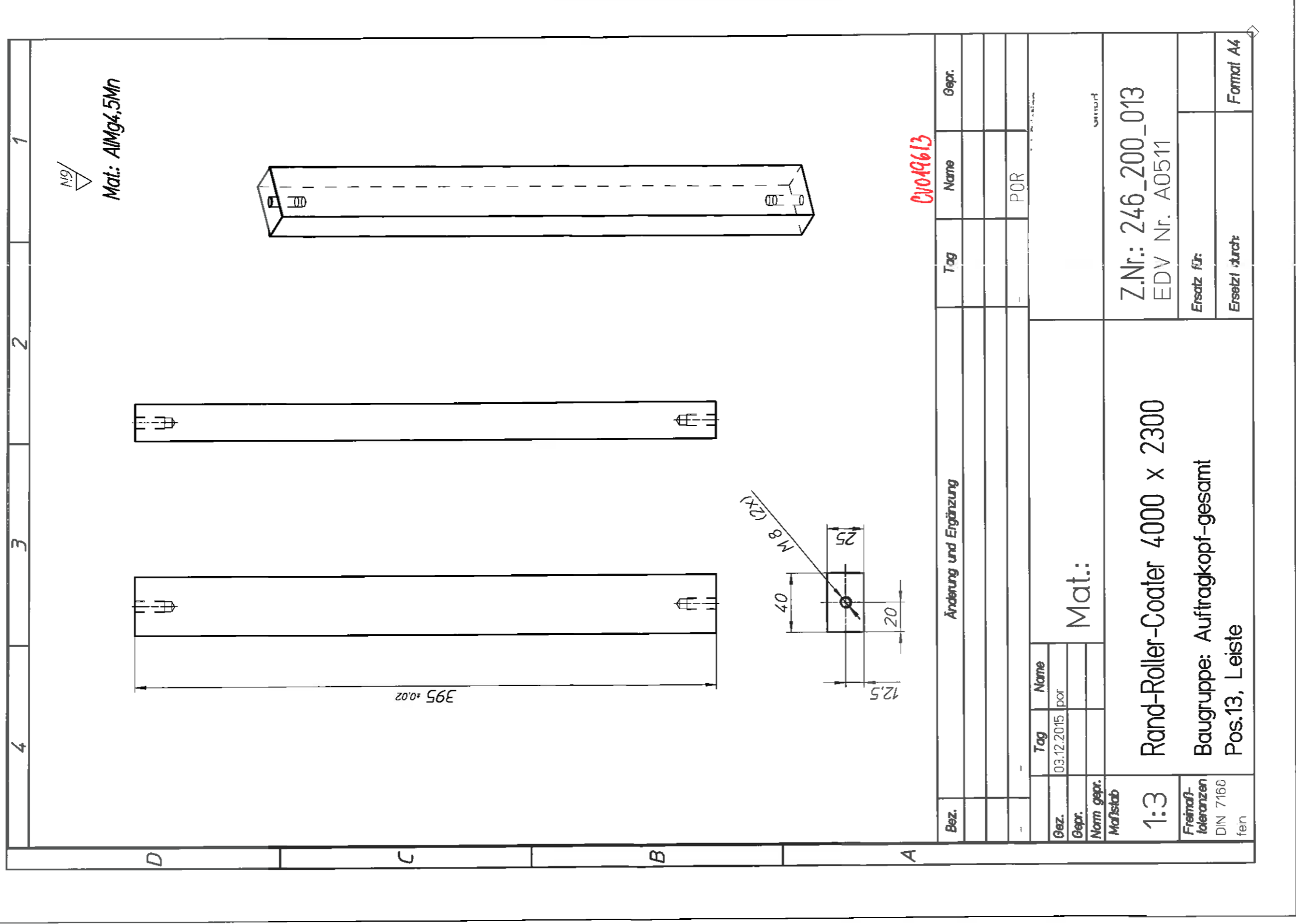

N9/
Mat.: AlMg4.5Mn

01049613

Bez.	Änderung und Ergänzung		Tag	Name	Gepr.
				POR	
Gez.	Tag	Name			
	03.12.2015	por			
Gepr.					
Norm. gepr.					
Maßstab			Mat.:		
1:3			Z.Nr.: 246_200_013 EDV Nr. A0511		
Freimaß- toleranzen DIN 7160 fein	Rand-Roller-Coater 4000 x 2300		Ersatz für:		
	Baugruppe: Auftragkopf-gesamt		Ersetzt durch:		Format A4
	Pos.13, Leiste				

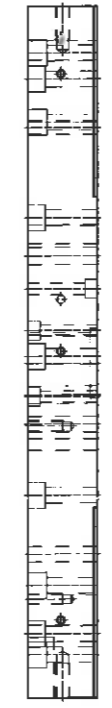
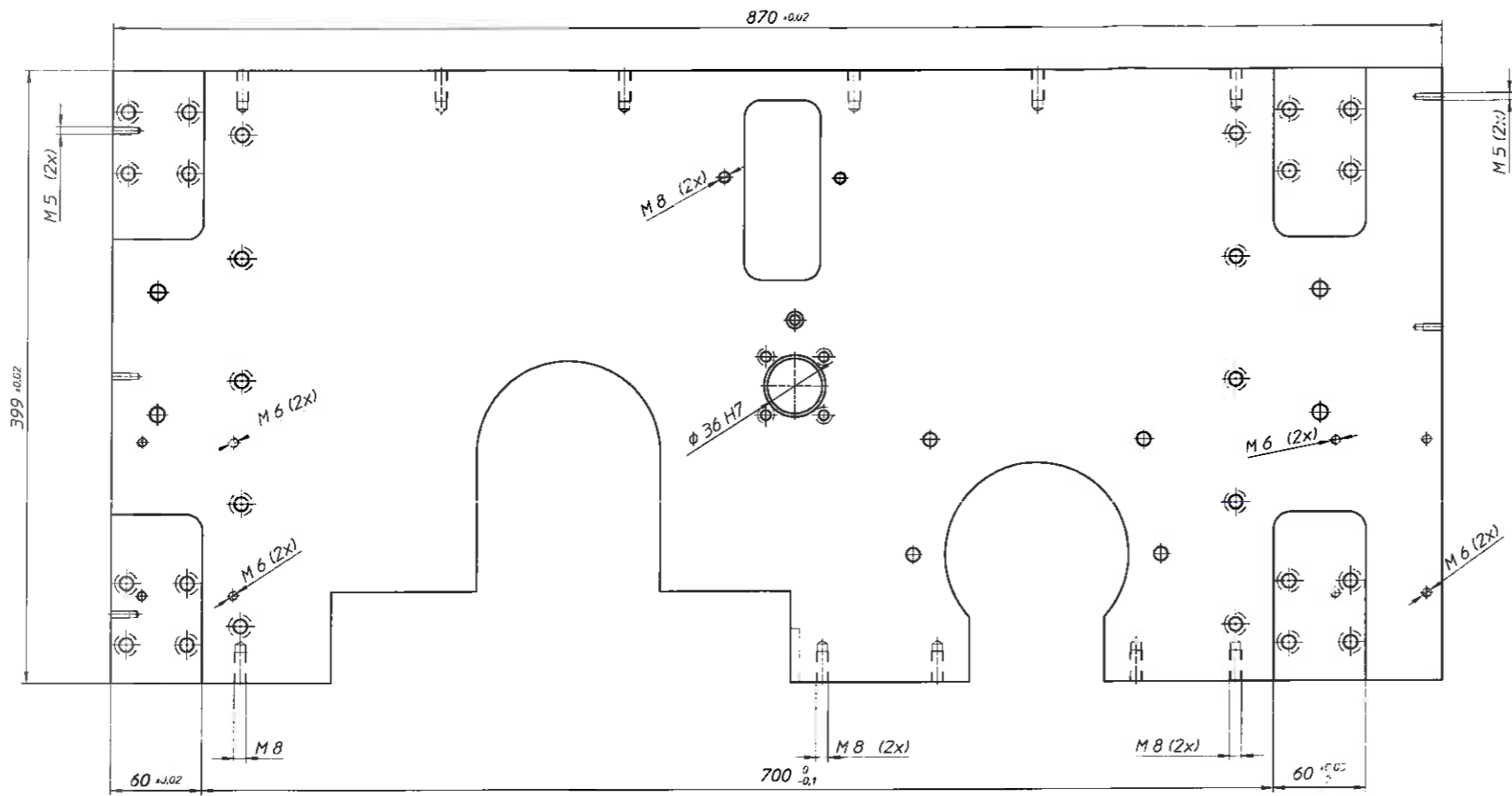

Maßstab 1:4

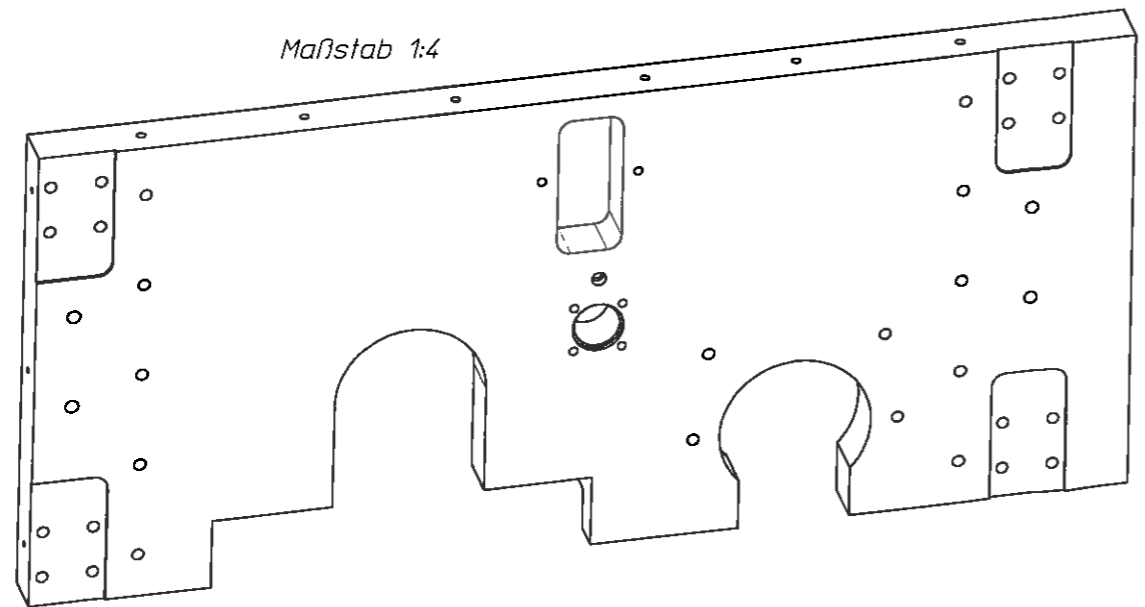

NS/
Mat: AlMg4,5Mn

CV019612

Bez.	Änderung und Erganzung		Tag	Name	Gepr.
				POR	
	Tag	Name	Mat.:		
Gez.	03.12.2015	por			
Gepr.					
Norm gepr.					
Maßstab	1:3		Rand-Roller-Coater 4000 x 2300		
Frei- toleranzen DIN 7168 fein	Baugruppe: Auftragkopf-gesamt Pos.12, Stimplatte		Z.Nr.: 246_200_012 EDV Nr. A0511		
	Ersatz fur:				
	Ersetzt durch:				Format A2

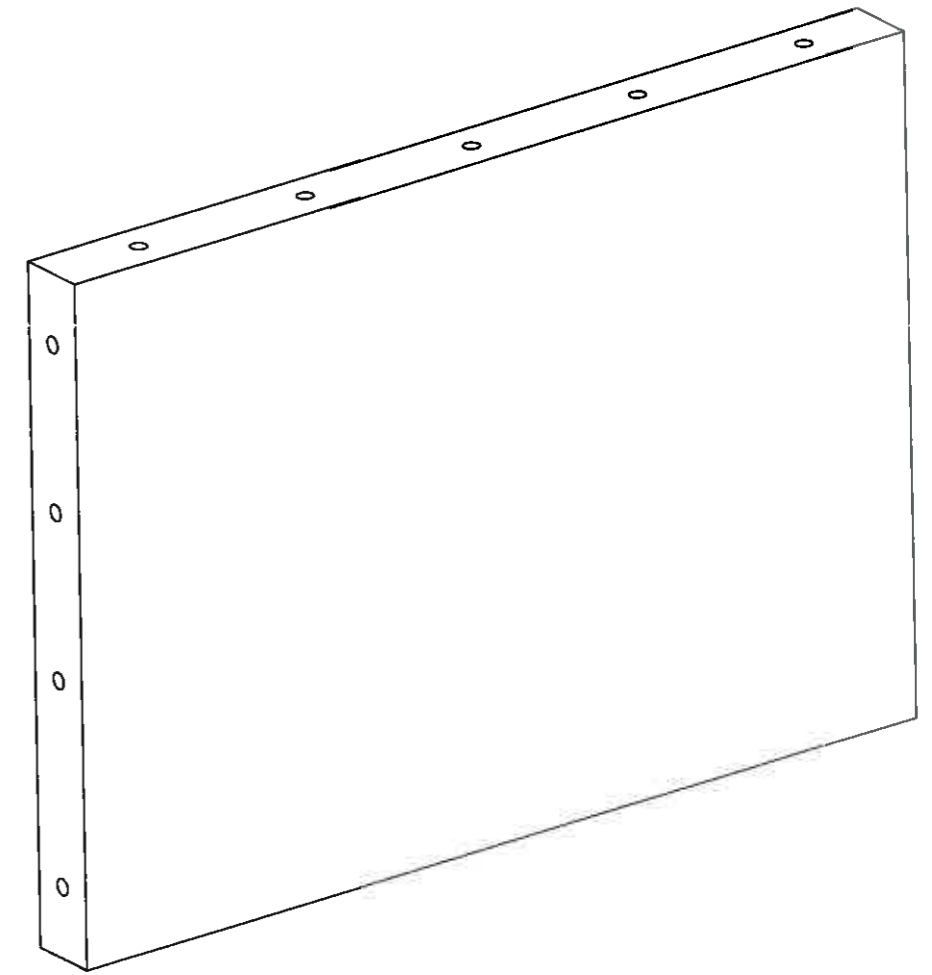
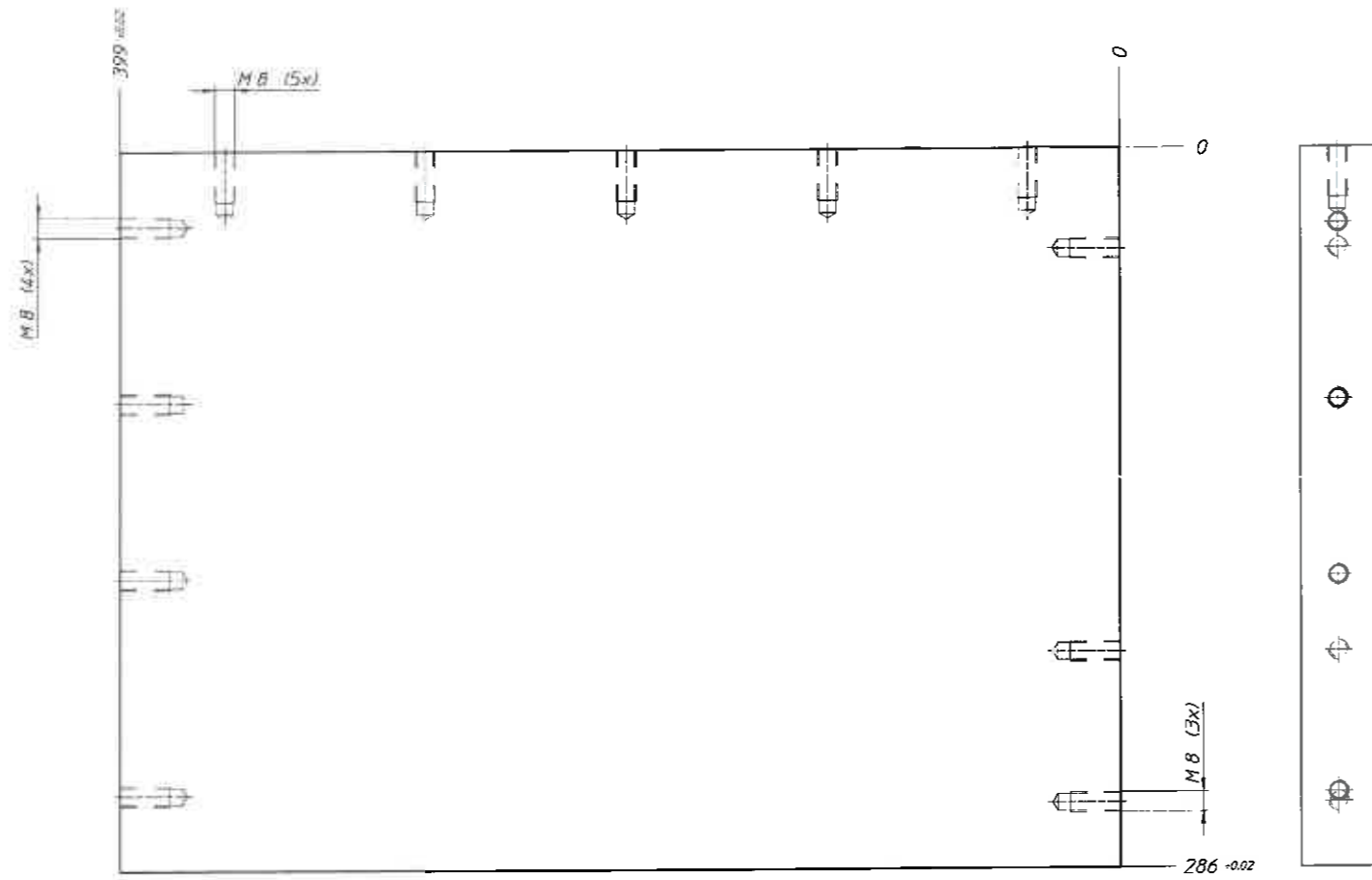
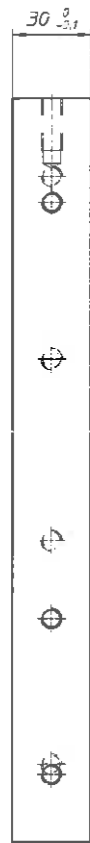

Mat.: AlMg4,5Mn

CV019611

Bez.	Änderung und Ergänzung		Tag	Name	Gepr.
				POR	
	Tag	Name	Mat.:		
Gez.	03.12.2015	por			
Gepr.					
Norm. gepr.					
Maßstab	1:2		Rand-Roller-Coater 4000 x 2300		Z.Nr.: 246_200_011
Freimaß- toleranzen DIN 7168 fan			Baugruppe: Auftragkopf-gesamt Pos.11, Seitenplatte-2		EDV Nr. A0511
				Ersatz für:	
				Ersetzt durch:	Format A2

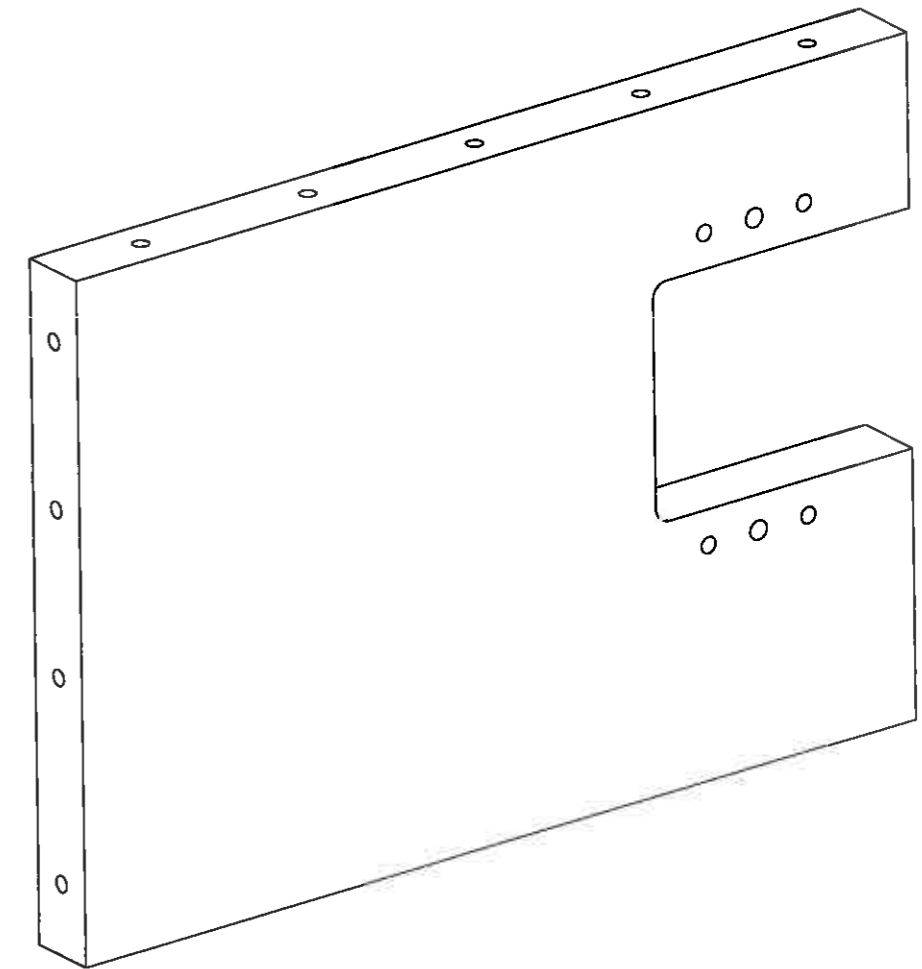
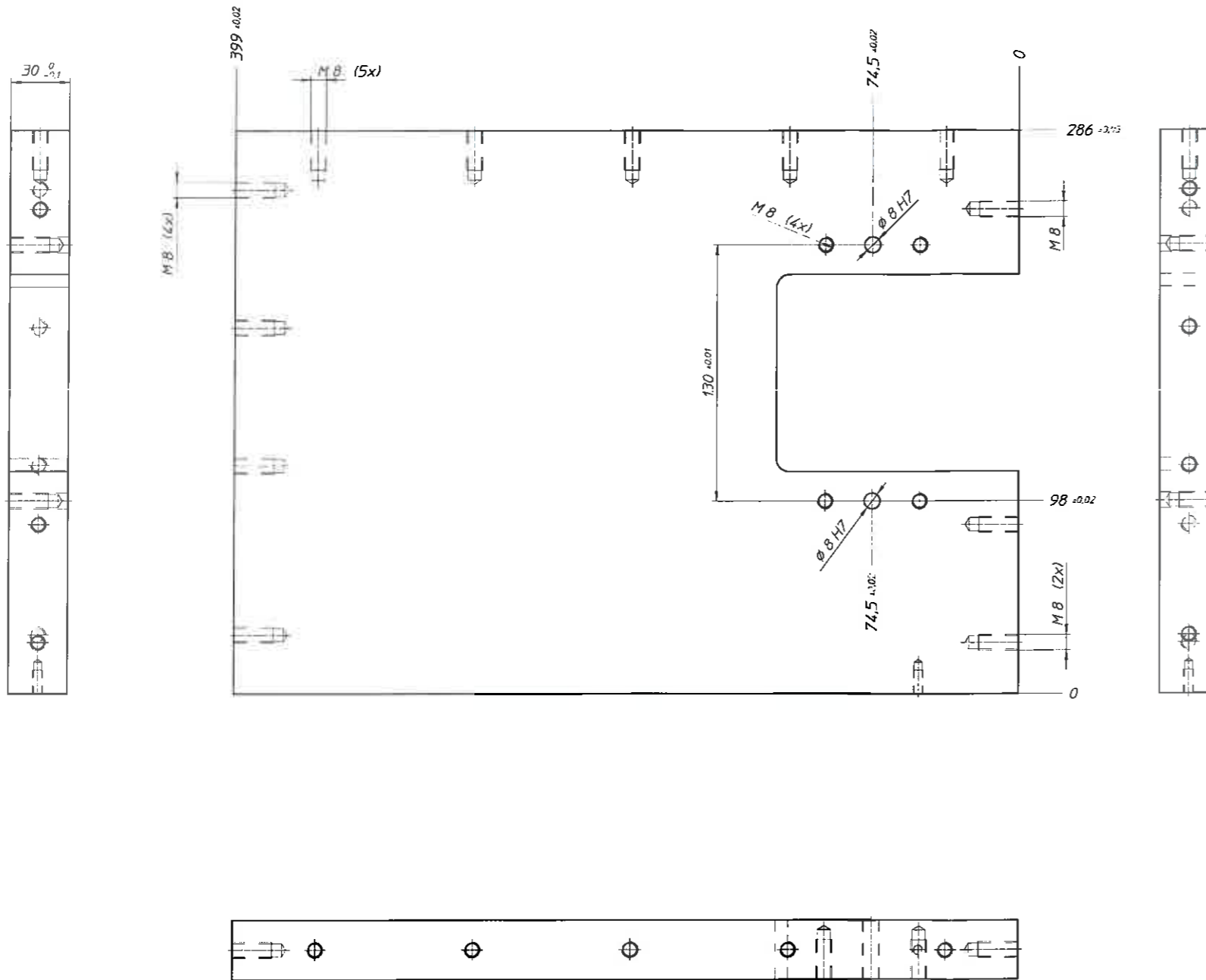



 Mat: AlMg4,5Mn

Fehlende Maße von 3D Step bzw. dxf-File entnehmen

CV019610

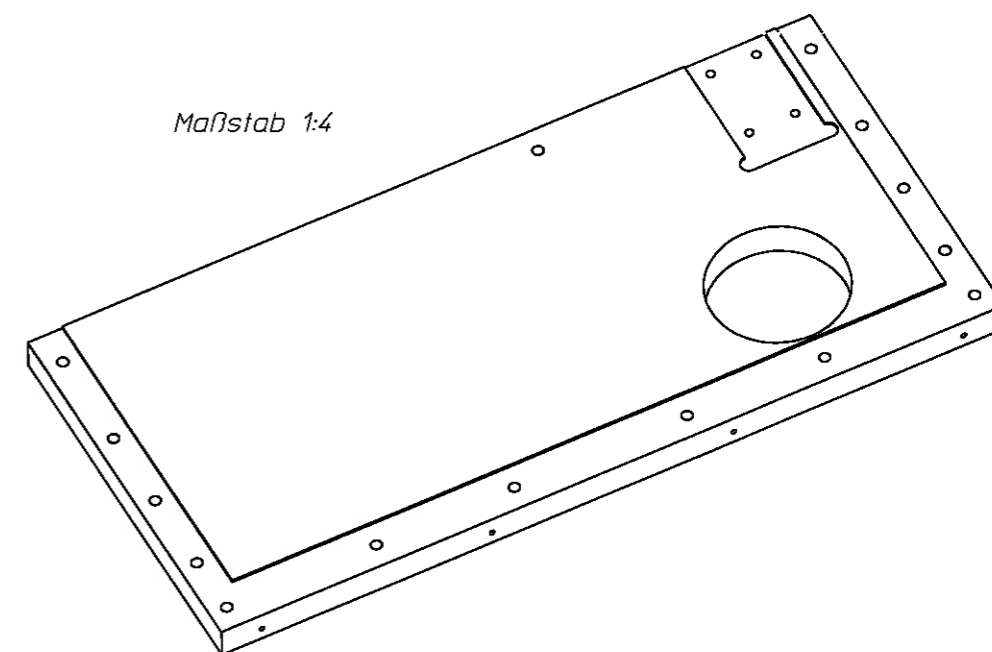
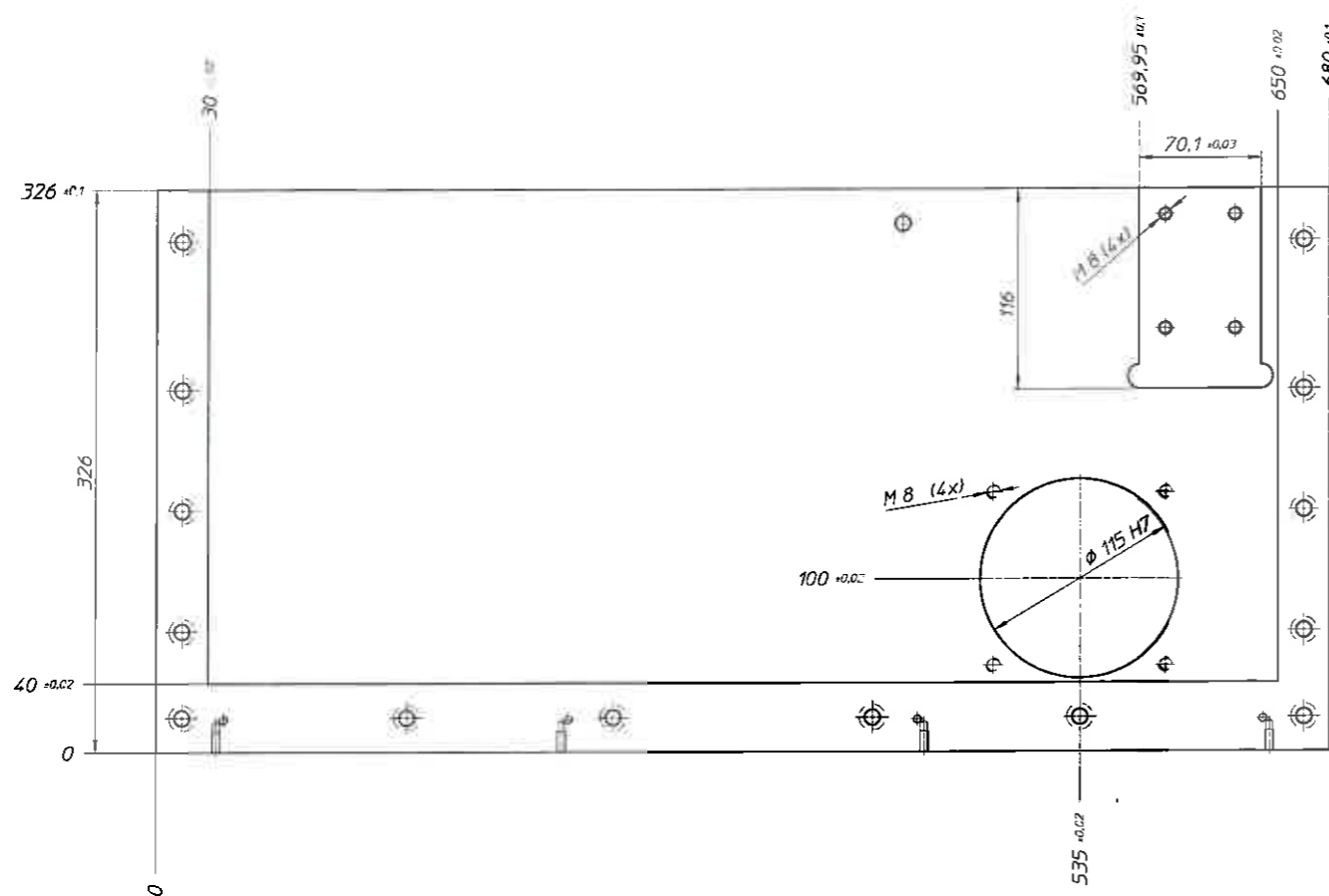
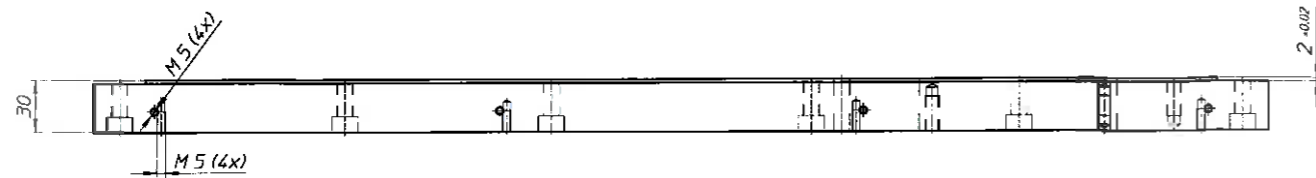
Bez.	Änderung und Ergänzung		Tag	Name	Gepr.
				PCR	
	Tag	Name	Mat:		
Gez.	03.12.2015	oor			
Gepr.					
Norm. gepr.					
Maßstab	1:2		Rand-Roller-Coater 4000 x 2300		Z.Nr.: 246_200_010 EDV Nr. A0511
Fräsmäßigkeiten DIN 7168 fein	Baugruppe: Auftragkopf-gesamt Pos.10, Seitenplatte-1		Ersatz Nr:		
			Ersetzt durch:		Format A2



Mat: AlMg4,5Mn

01019608

Bez.	Aenderung und Ergaenzung		Tag	Name	Gepr.
				POR	
	Tag	Name			
Gez.	02.12.2015	por			
Gepr.			Mat:		
Norm. gepr.					
Maßstab	1:3		Rand-Roller-Coater 4000 x 2300		Z.Nr.: 246_200_009
Frei- toleranzen DIN 7168			Baugruppe: Auftragkopf-gesamt		EDV Nr. A0511
fern			Pos.9, Deckplatte		Ersetzt für:
			Ersetzt durch:		Format A2

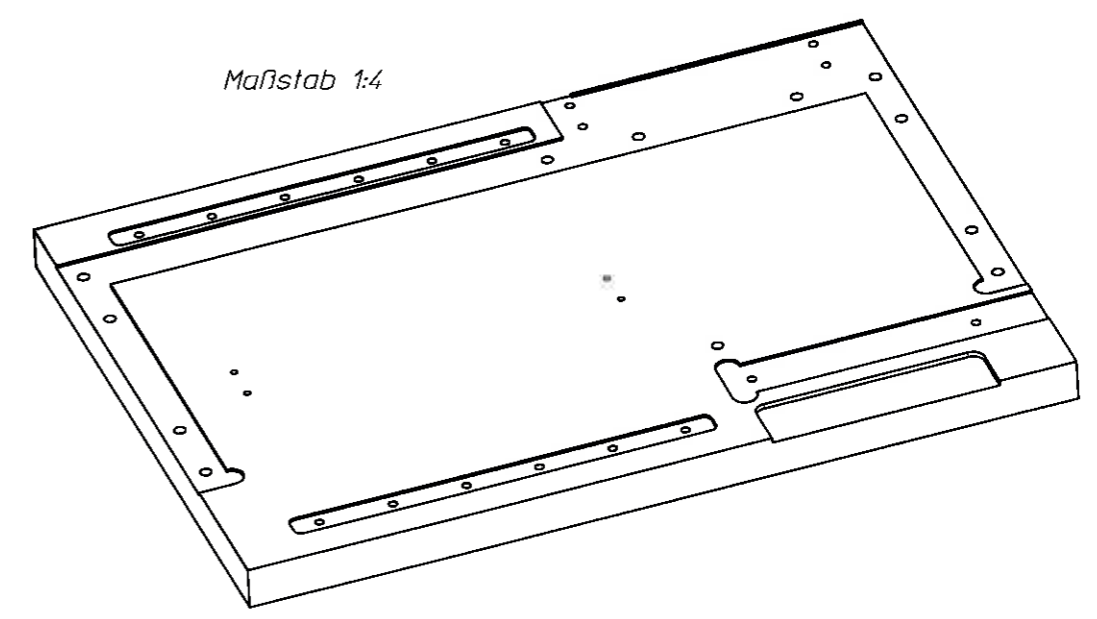
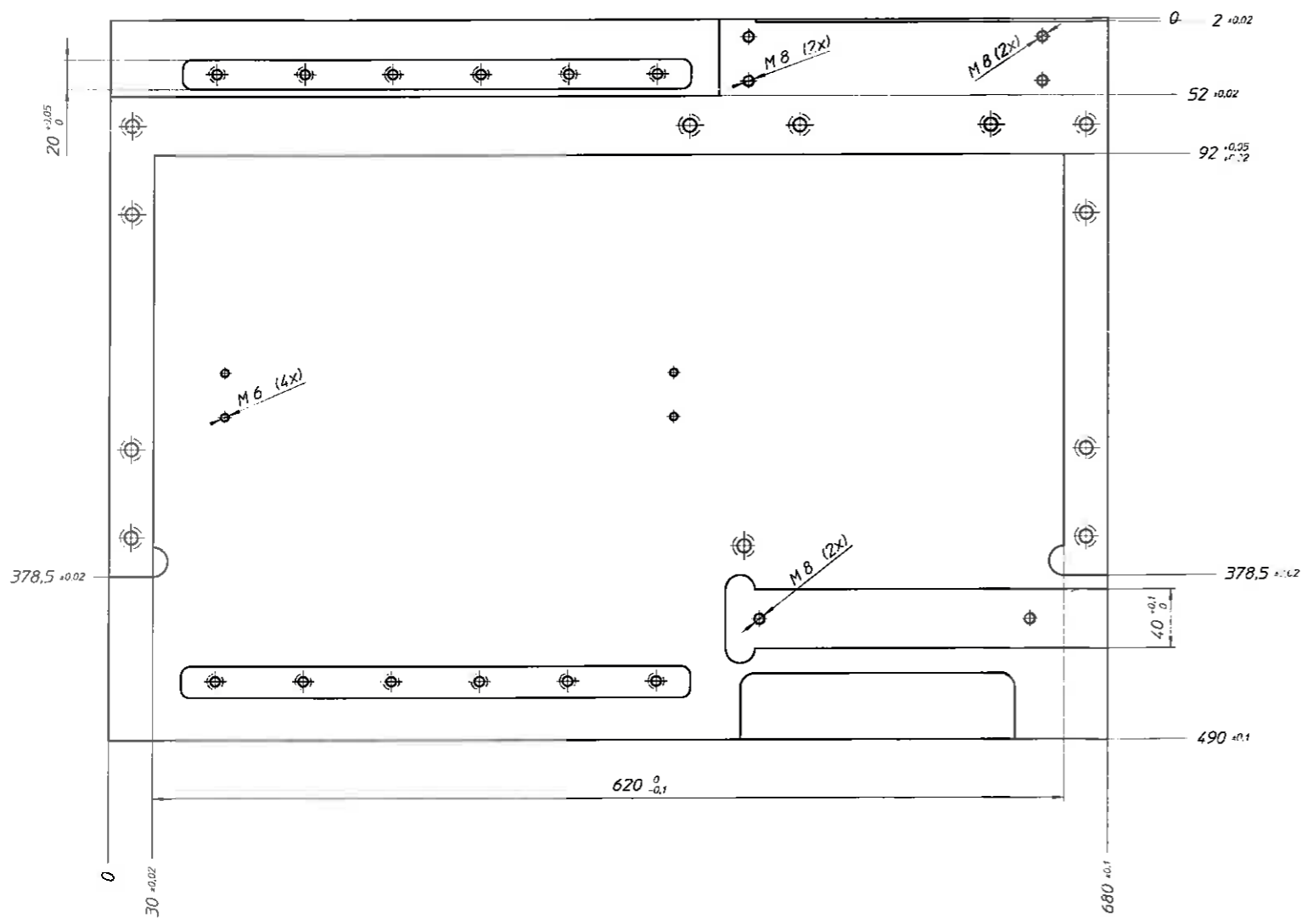
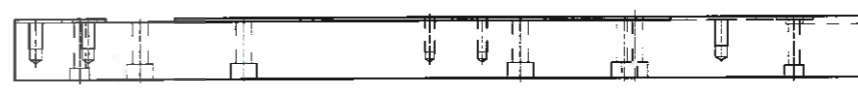
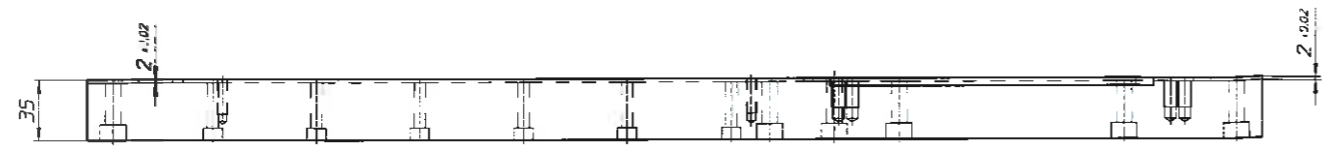

Mat: AlMg4,5Mn

01049605

Bez.	Änderung und Ergänzung		Tag	Name	Gepr.
				POR	
	Tag	Name	Mat:		
Gez.	02.12.2015	par			
Gepr.					
Norm. gepr.					
Maßstab	1:3		Rand-Roller-Coater 4000 x 2300		
Freimaßtoleranzen DIN 7168			Baugruppe: Auftragkopf-gesamt Pos.8, Grundplatte		
			Z.Nr.: 246_200_008 EDV Nr. A0511		
			Ersatz für:		
			Ersetzt durch:		Format A2

D

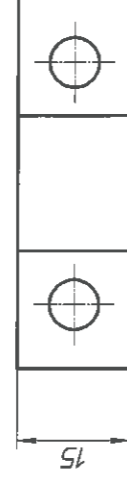

C

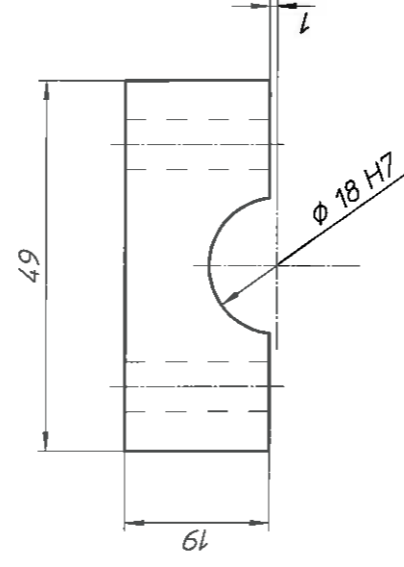

B



Mat.: 1.1730

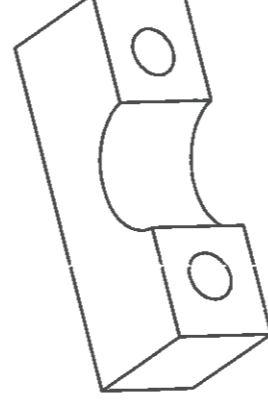

A

01919602

Bez.		Änderung und Ergänzung		Tag	Name	Gepr.
					POR	
Gez.	01.12.2015			Mat.:		
Gepr.						
Norm. gepr.						
Maßstab						
1:1				Z.Nr.: 246_200_007		
Freimaß- toleranzen DIN 7168 fein				EDV Nr. A0511		
				Ersatz für:		
				Ersetzt durch:		Format A4



Mat.: 1.1730

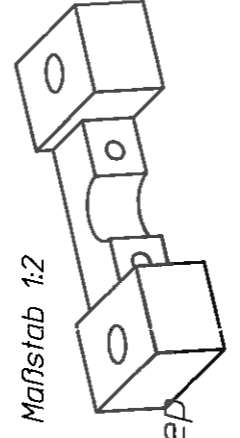
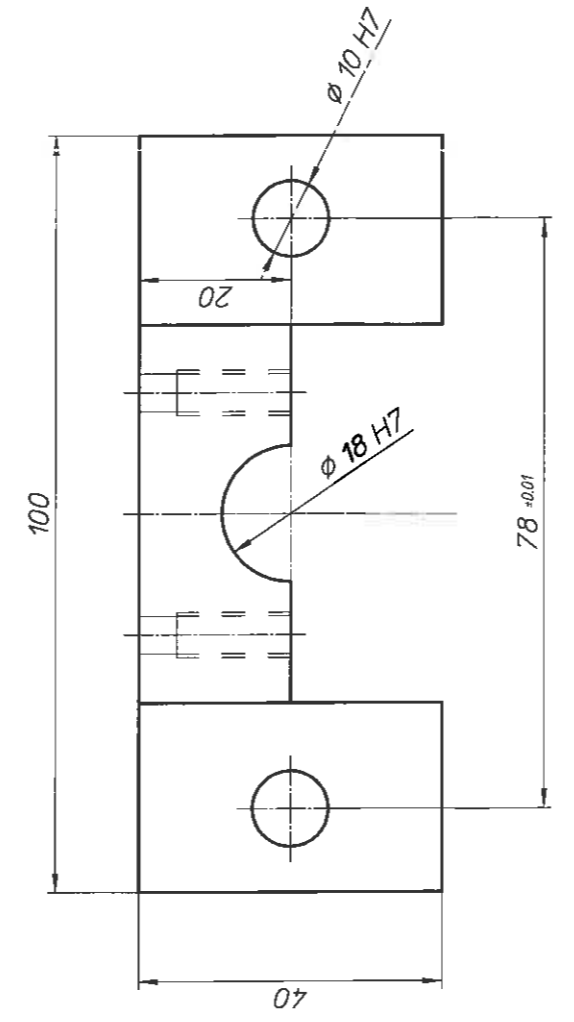
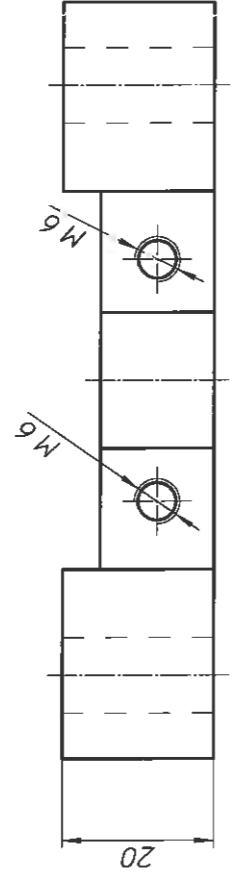

Maßstab 1:2

Fehlende Maße von 3D Step bzw. dxf-File entnehmen

61019-598

Bez.	Änderung und Ergänzung		Tag	Name	Gepr.
				POR	

Gez.	Tag	Name
	01.12.2015	por

Mat.:

1:1	Rand-Roller-Coater 4000 x 2300		Z.Nr.: 246_200_006
Freimaß- toleranzen	Baugruppe: Auftragkopf-gesamt		EDV Nr. A0511
DIN 7168 fein	Pos.6, Halteplatte-unten		Ersatz für:
			Ersetzt durch:
			Format A4

8 7 6 5 4 3 2 1

F
E
D
C
B
A

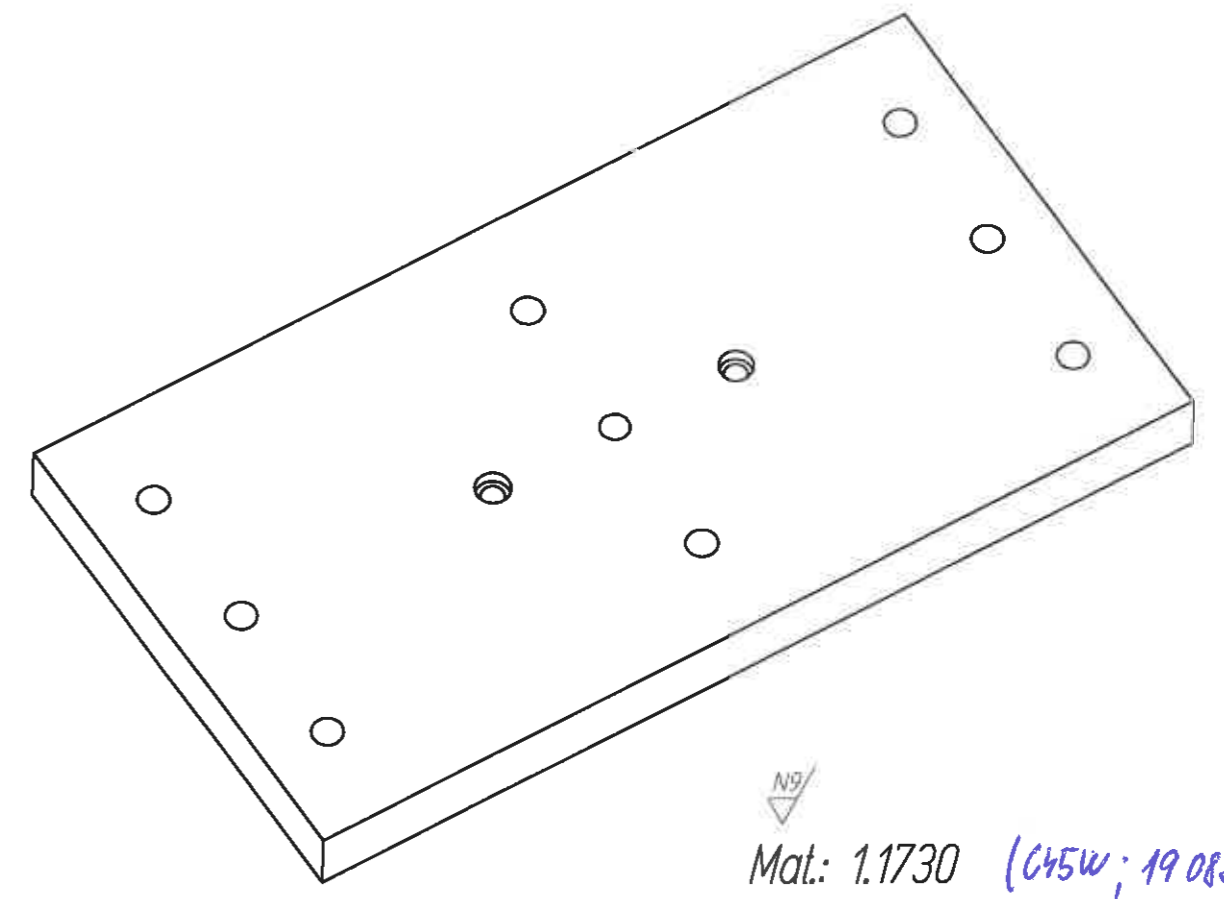
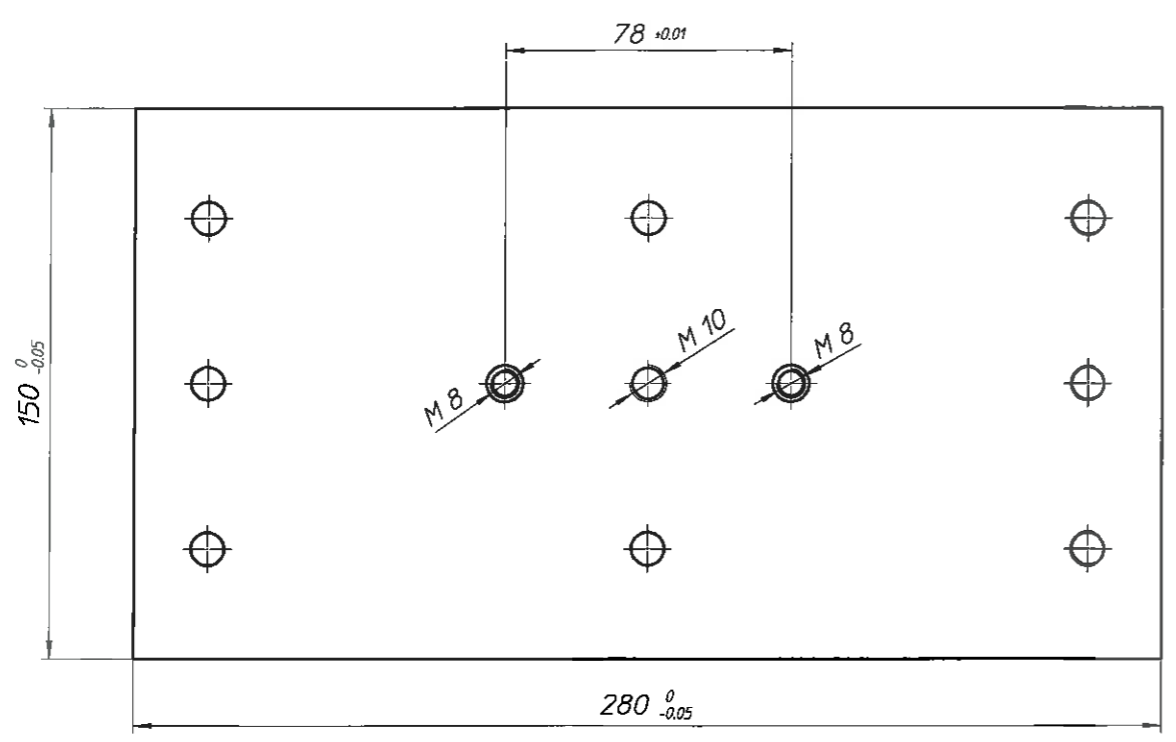
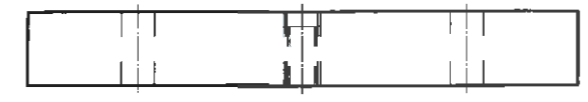
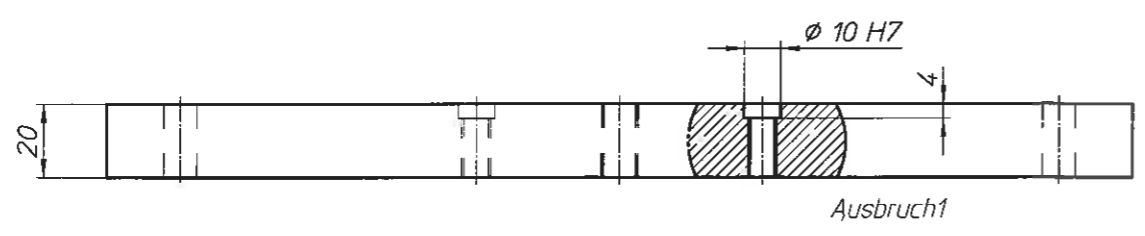

N9
Mat.: 1.1730 (C45W; 19 083)
CV019597

Bez.	Änderung und Ergänzung		Tag	Name	Gepr.
				POR	
	Tag	Name	Machines for Ceramic Ink Printing		
Gez.	01.12.2015	por	Mat.:	Z.Nr.: 246_200_005 EDV Nr. A0511	
Gepr.					
Norm gepr.					
Maßstab	1:2		Rand-Roller-Coater 4000 x 2300		
Freimaßtoleranzen DIN 7168 fein			Baugruppe: Auftragkopf-gesamt Pos.5, U9C-Platte		Ersatz für:
				Ersetzt durch:	Format A3

8 7 6 5

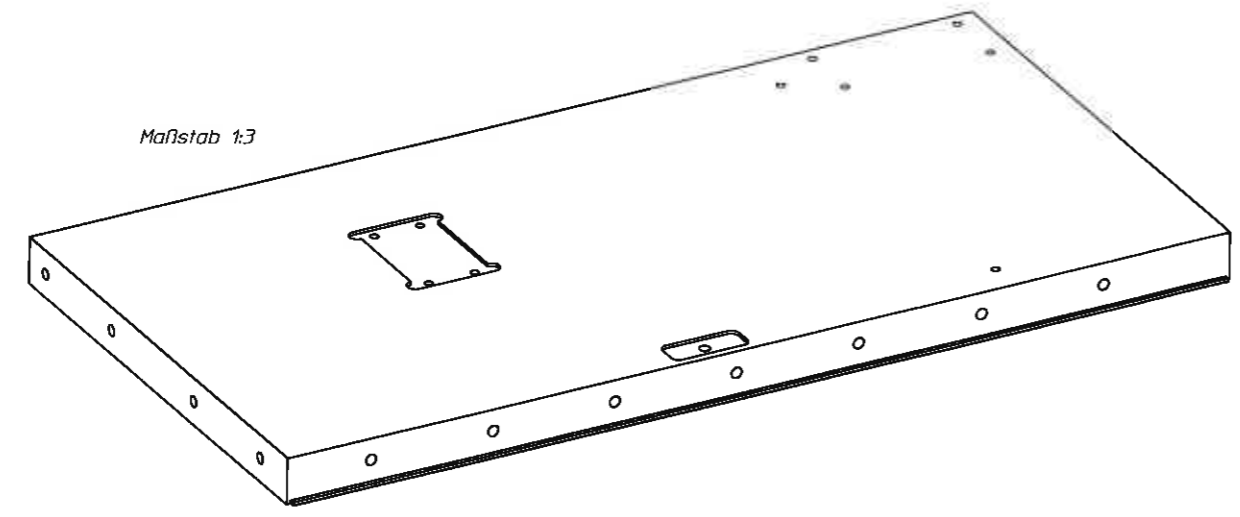
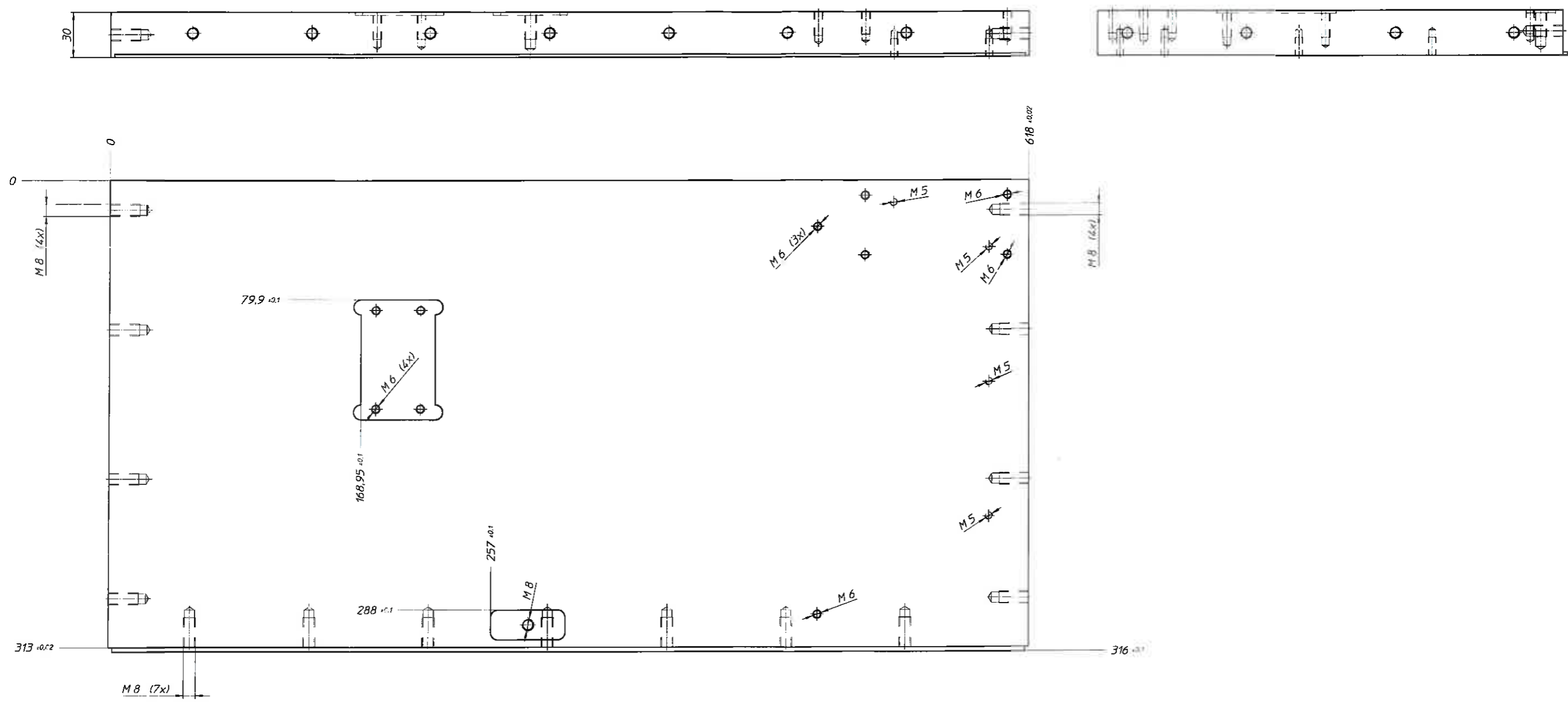

Maßstab 1:3

Mat: AlMg4,5Mn

Fehlende Maße von 3D Step bzw. dxf-File entnehmen

Cv019596

Bez.	Änderung und Erganzung		Tag	Name	Gepr.
				POR	
	Tag	Name	Mat.:		
Gez.	01.12.2015	por			
Gepr.					
Norm. gepr.					
Maßstab	1:2				
Freimaßtoleranzen DIN 7168 fan	Rand-Roller-Coater 4000 x 2300				Z.Nr.: 246_200_004 EDV Nr. A0511
	Baugruppe: Auftragkopf-gesamt Pos.4, Seitenplatte-2				Ersatz für:
					Ersatz durch:
					Format A2

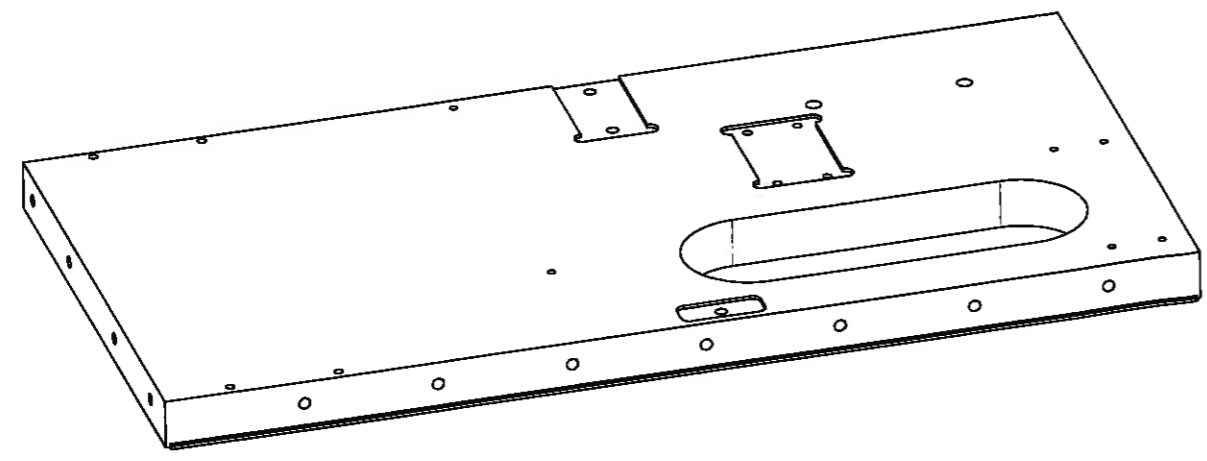
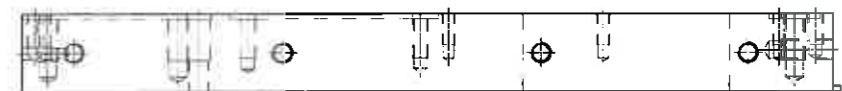
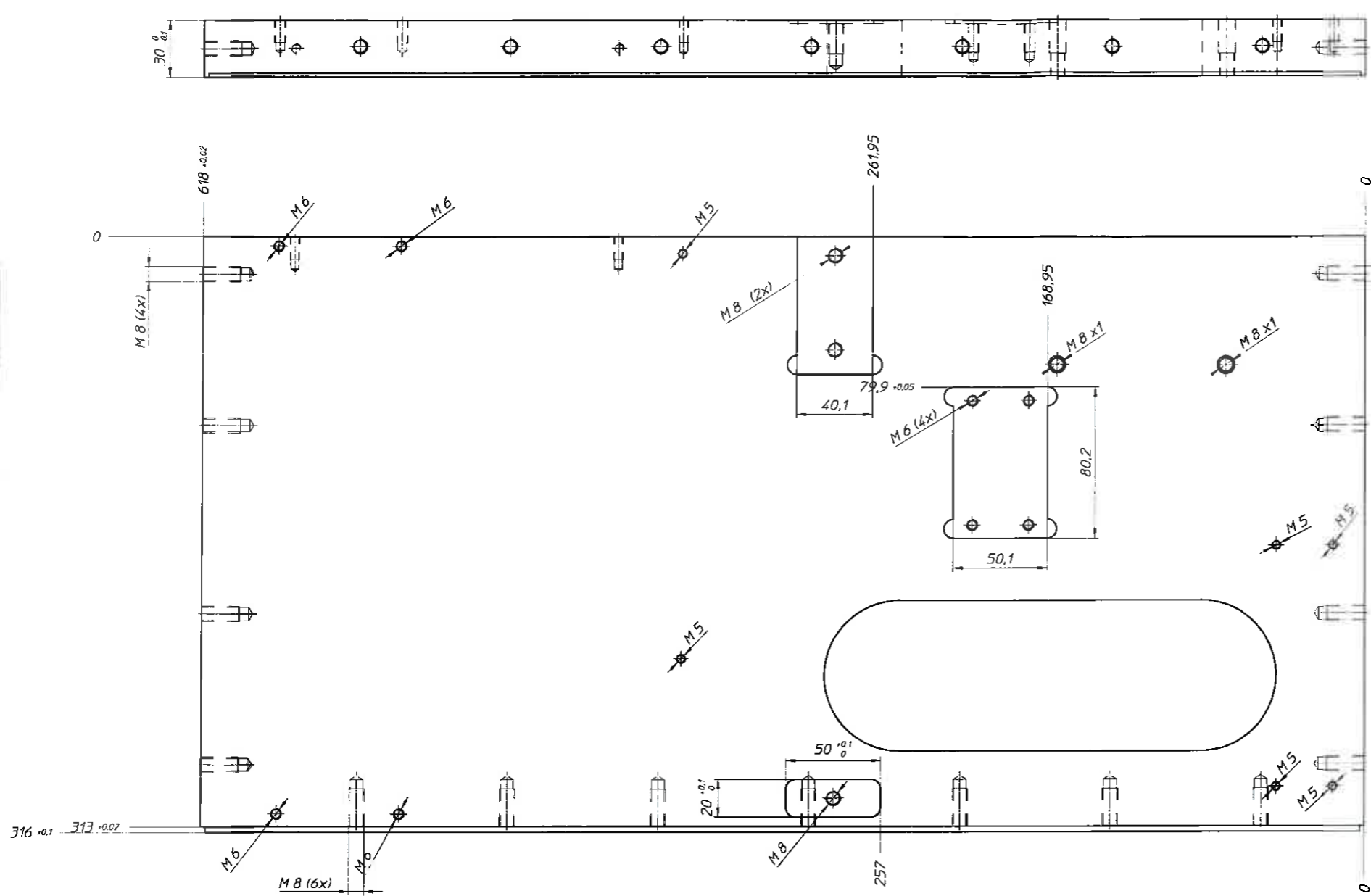

Maßstab 1:3

Fehlende Maße von 3D Step
bzw. dxf-File entnehmen

1:9
Mat: A1Mg4,5Mn

CN019595

Bez.	Änderung und Ergänzung			Tag	Name	Gepr.
					PAB	
Gez.	Tag	Name	Mat.:			
Gepr.	02.12.2015	por				
Norm gepr.						
Maßstab	1:2		Rand-Roller-Coater 4000 x 2300		Z.Nr.: 246_200_003 EDV Nr. A0511	
Freimä- toleranzen DIN 7168	Baugruppe: Auftragkopf-gesamt Pos.3, Seitenplatte-1			Ersatz für:		
fan				Ersatz durch:		Format A2

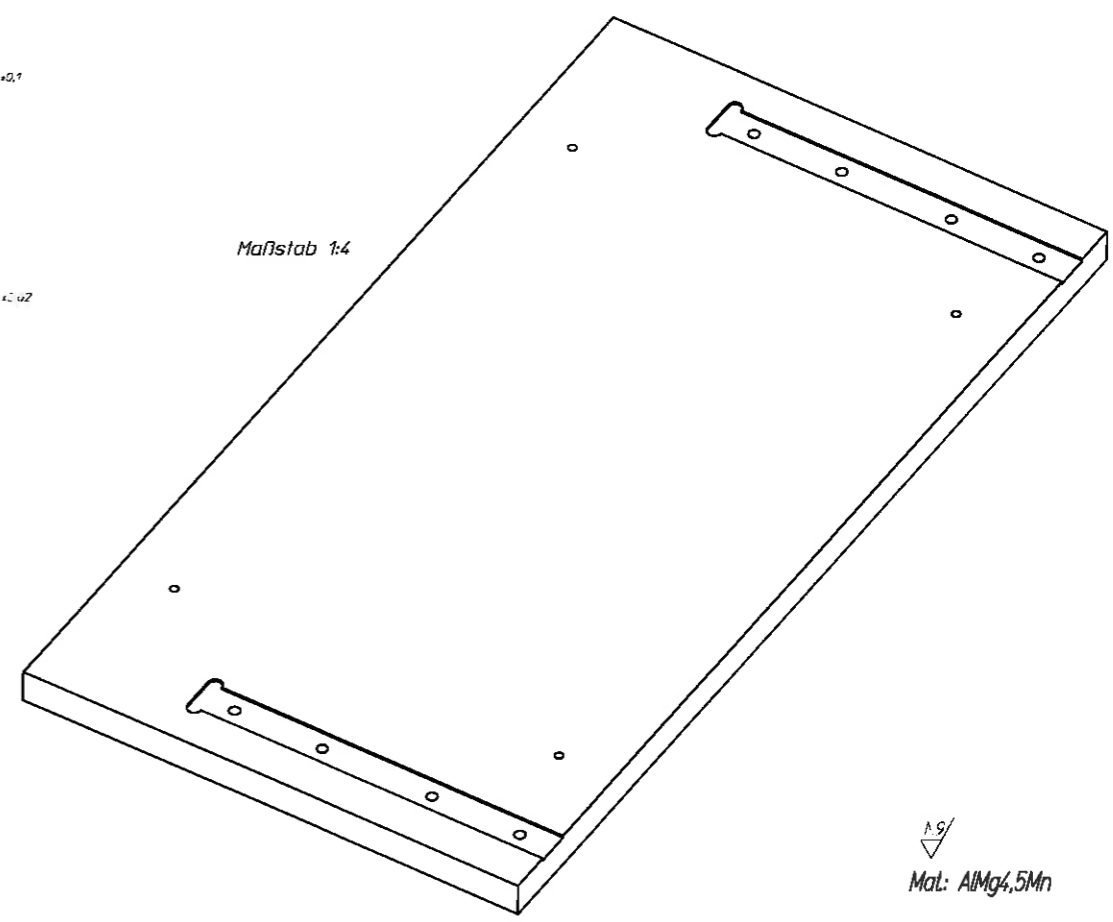
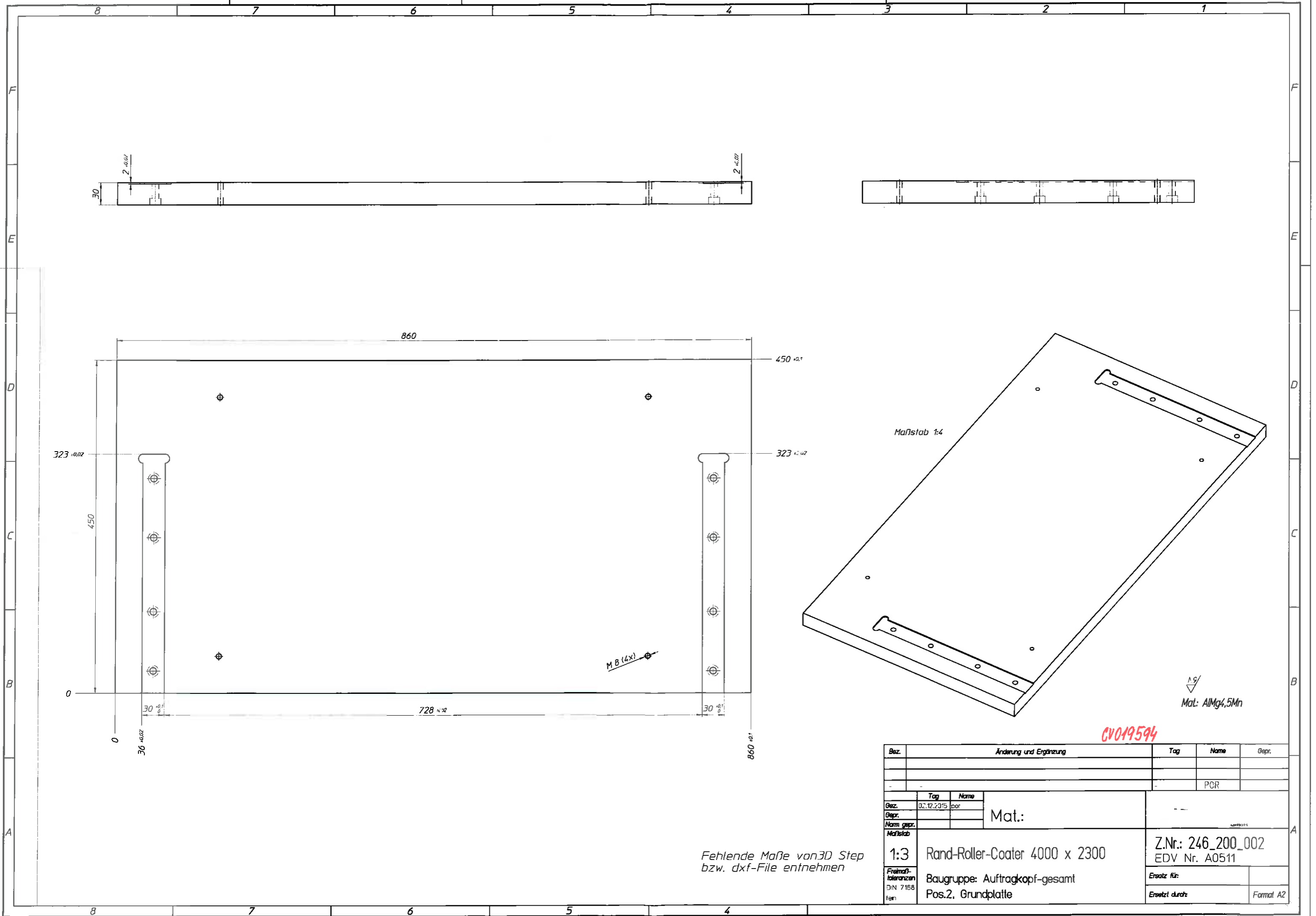

Bez.	Änderung und Ergänzung		Tag	Name	Gepr.
				POB	
	Tag	Name	Mat.:		
Gez.	02.12.2015	POB			
Gepr.					
Norm. gepr.					
Maßstab	1:3		Rand-Roller-Coater 4000 x 2300		
Freimaßtoleranzen DIN 7168			Baugruppe: Auftragkopf-gesamt Pos.2, Grundplatte		
Isen			Z.Nr.: 246_200_002 EDV Nr. A0511		
			Ersatz für:		
			Ersatz durch:		Format A2

Fehlende Maße von 3D Step
bzw. dxf-File entnehmen

019594

1:4
Mat.: AlMg4,5Mn

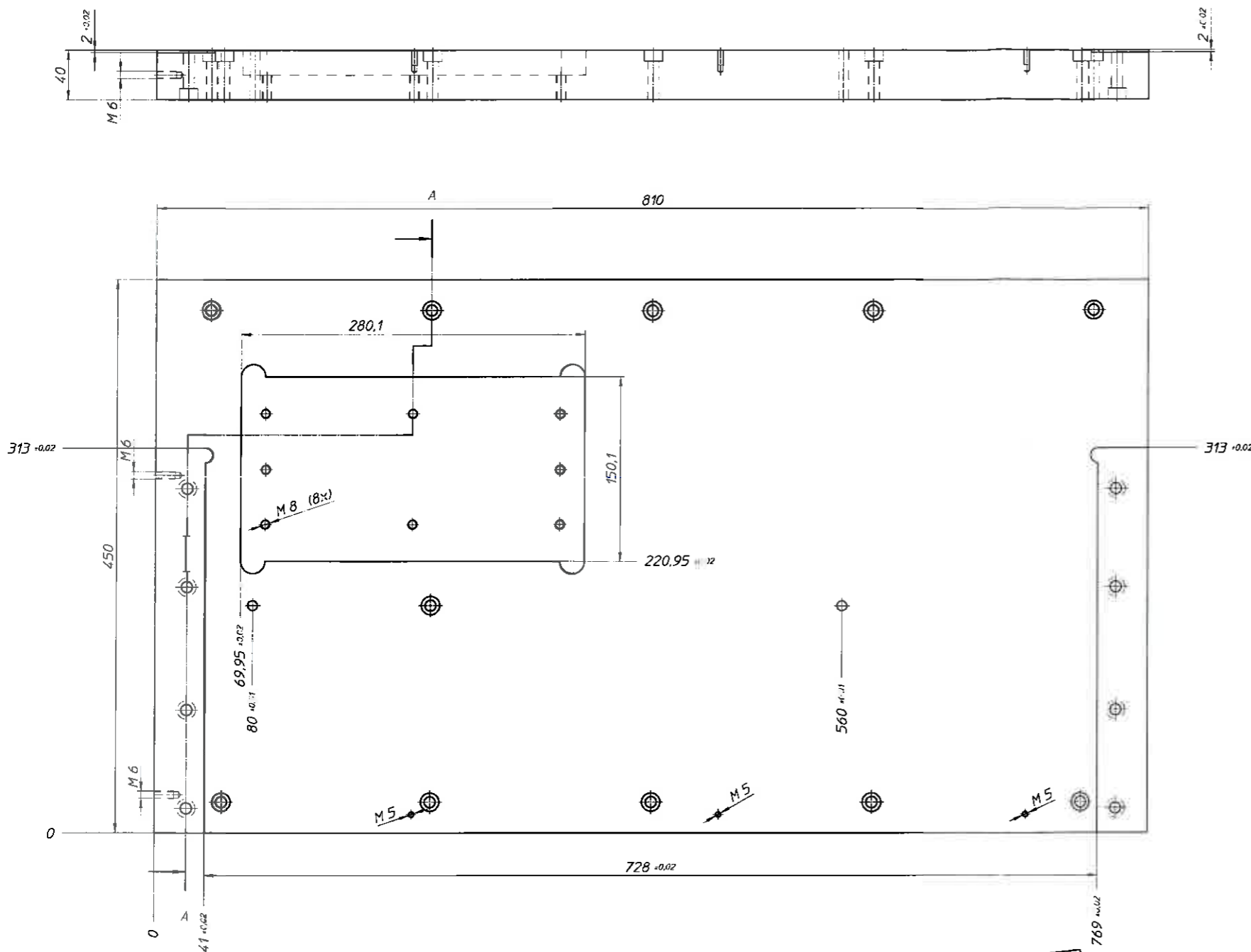

Schnitt A A

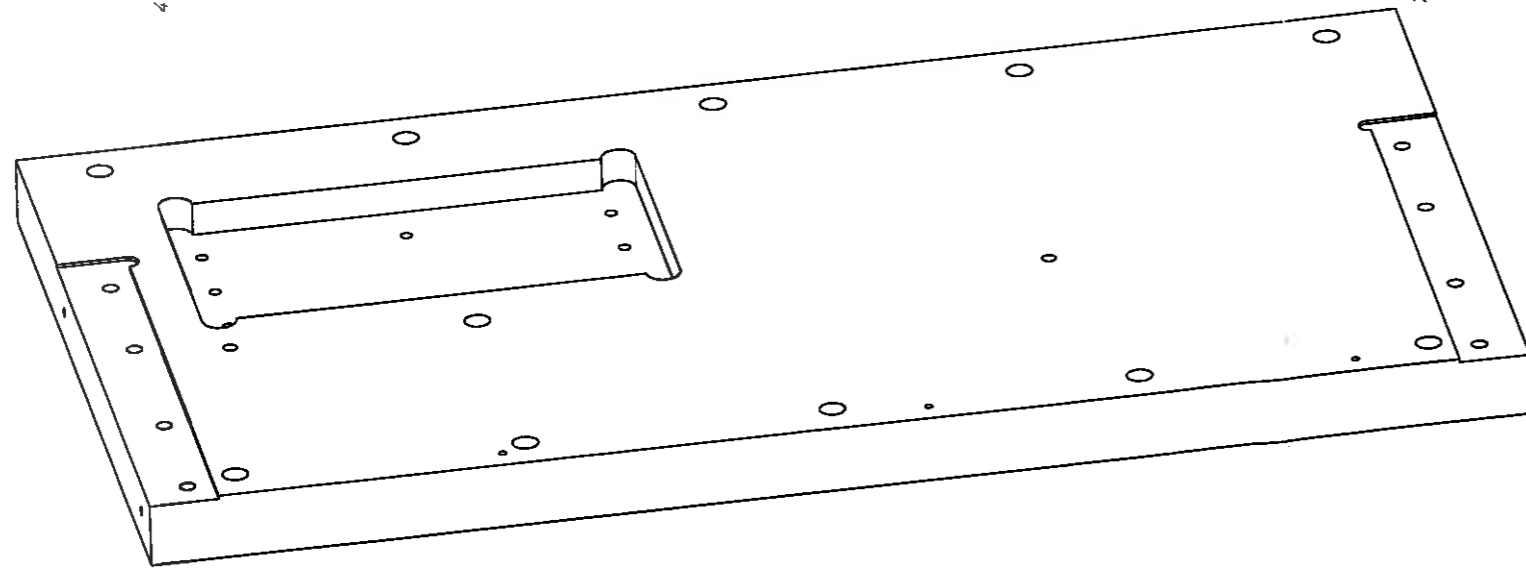

Mat: AlMg4,5Mn

01019593

Bez.	Änderung und Ergänzung			Tag	Name	Gepr.
					PCR	
	Tag	Name				
Gez.	02.12.2015	por				
Gepr.						
Norm. gepr.						
Maßstab	1:3		Mat:			
	Rand-Roller-Coater 4000 x 2300				Z.Nr.: 246_200_001 EDV Nr. A0511	
Formal-toleranzen DIN 7168	Baugruppe: Auftragkopf-gesamt		Ersatz für:			
len	Pos.1, Deckplatte		Ersetzt durch:		Format A2	

8 7 6 5 4 3 2 1

Schnitt A-A

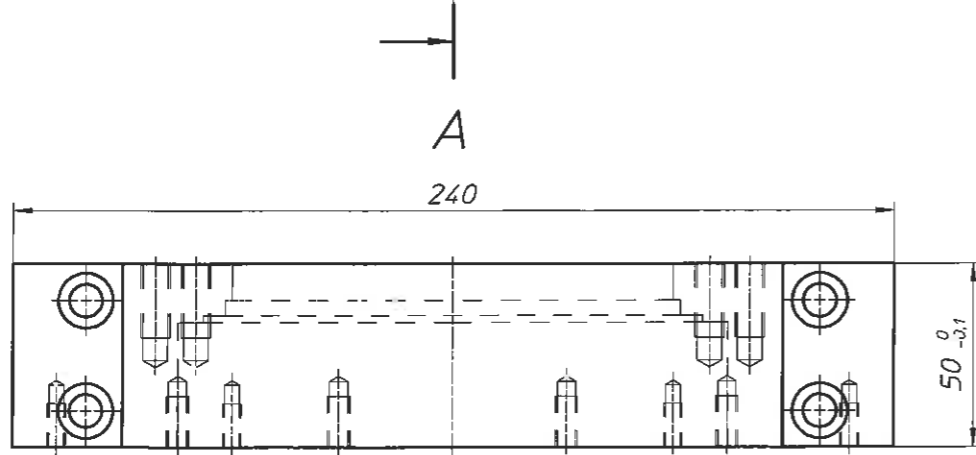
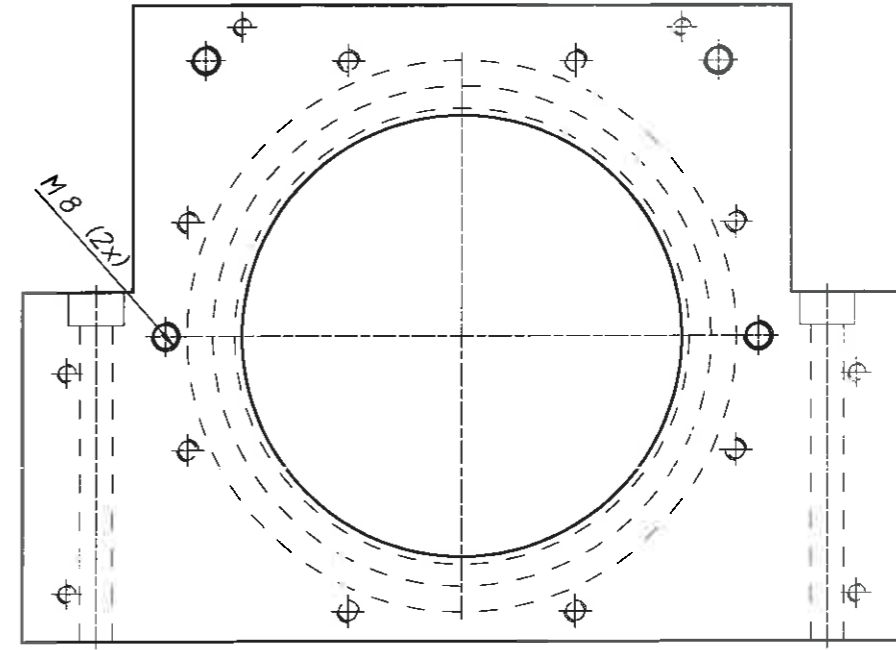
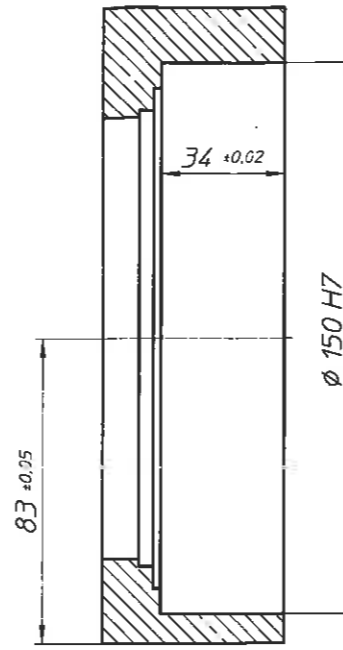
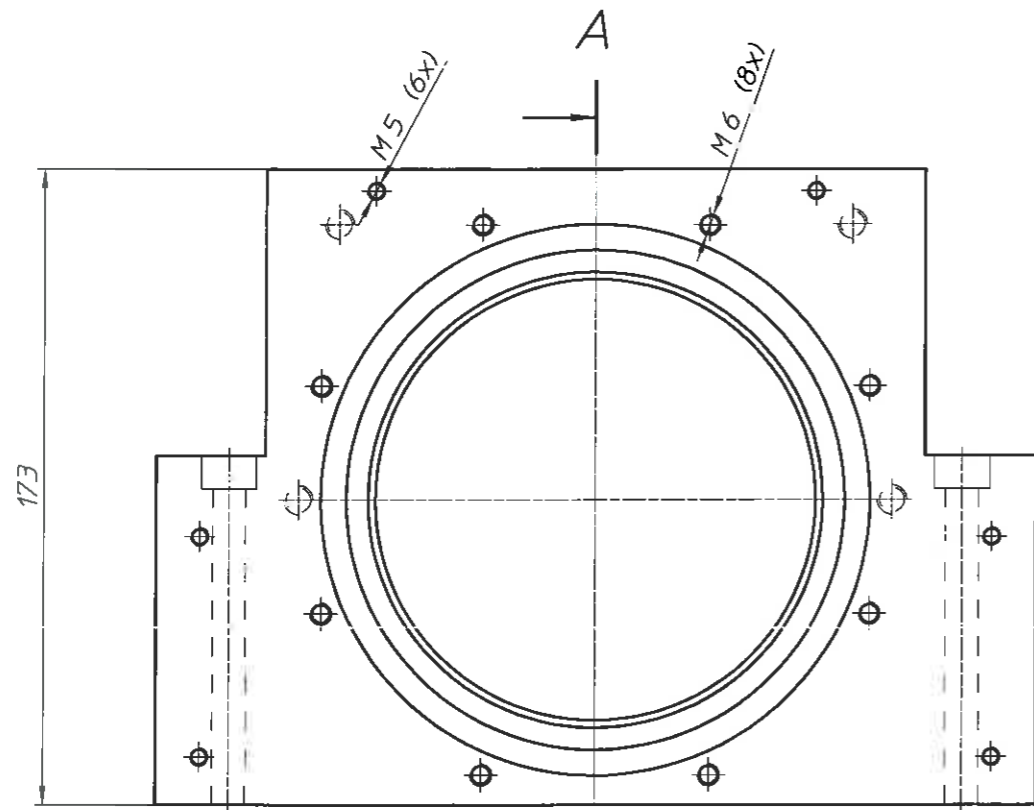

N9/
Mat.: AlMg4,5Mn

CV019626

Maßstab 1:4

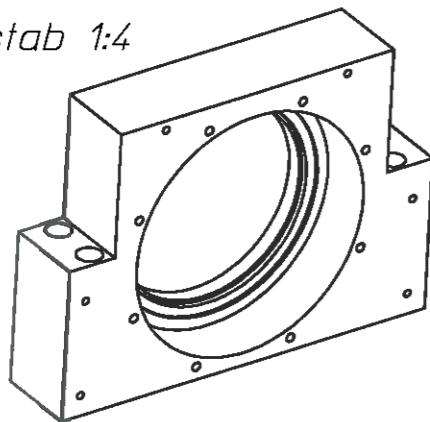

Maßstab 1:4

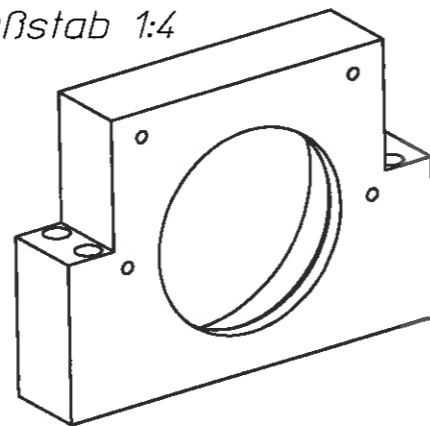

Bez.	Änderung und Ergänzung		Tag	Name	Gepr.
				POR	
Gez.	01.12.2015	por	Mat.: GmbH		
Gepr.					
Norm gepr.					
Maßstab					
1:2	Rand-Roller-Coater 4000 x 2300		Z.Nr.: 246_210_001		
Freimaß- toleranzen DIN 7168 fein	Baugruppe: Gummiwalze-gesamt Pos.1, Lagerbock-1		EDV Nr. A0511		
			Ersatz für:		
			Ersetzt durch:		Format A3

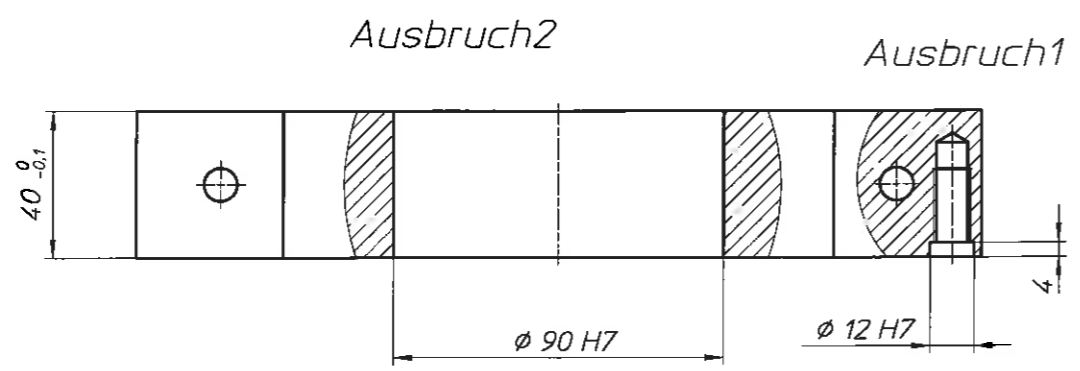
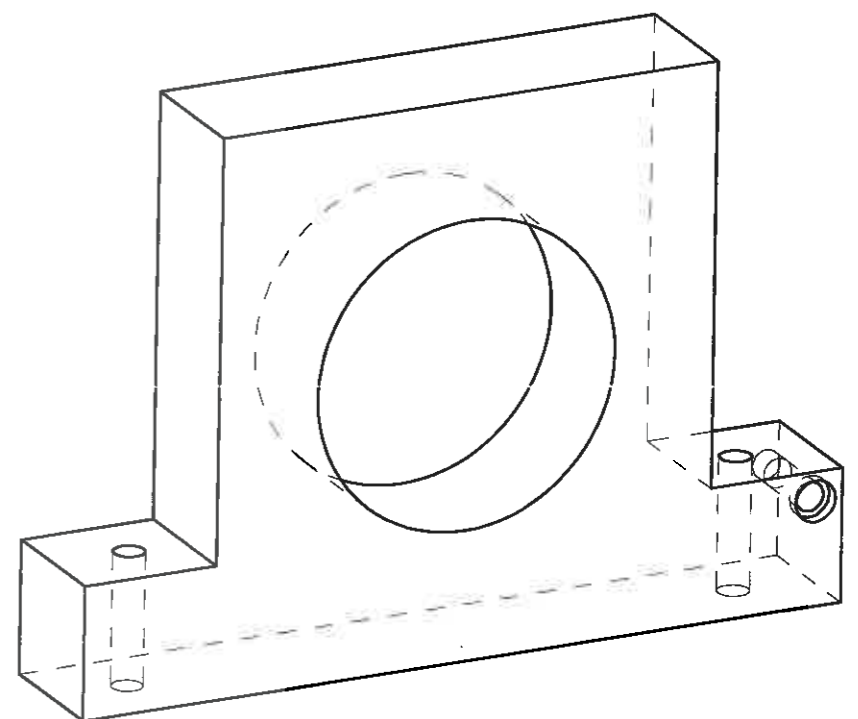
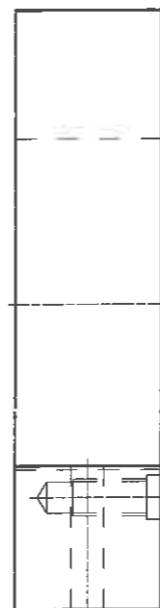
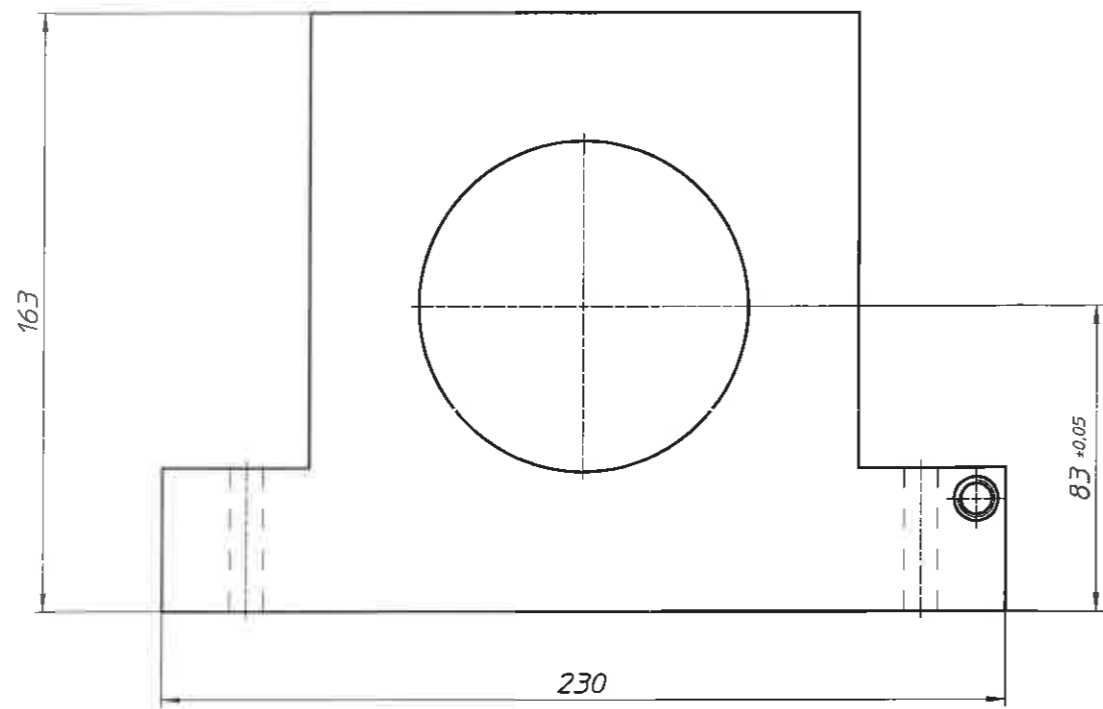

N9/
Mat: AlMg4,5Mn

CV019625

Bez.	Änderung und Ergänzung		Tag	Name	Gepr.
				POR	
	Tag	Name	Mat.:		
Gez.	01.12.2015	por			
Gepr.					
Norm gepr.			Z.Nr.: 246_210_002 EDV Nr. A0511		
Maßstab	1:2	Rand-Roller-Coater 4000 x 2300			
Freimaßtoleranzen DIN 7168 fein	Baugruppe: Gummiwalze-gesamt Pos.2, Lagerbock-2		Ersatz für:		Format A3
			Ersetzt durch:		

Schnitt A-A

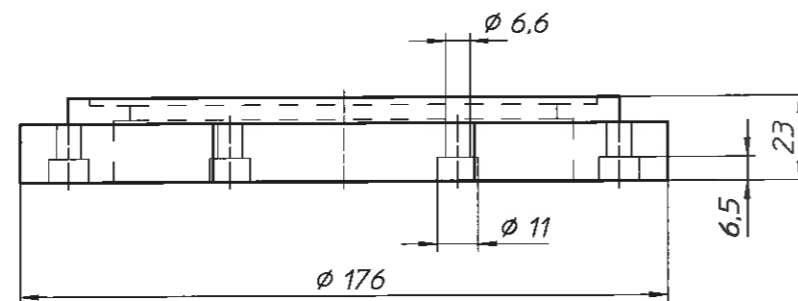
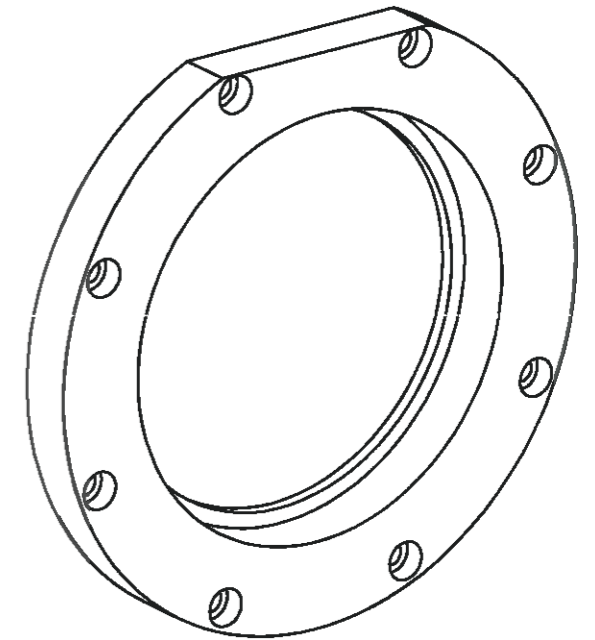
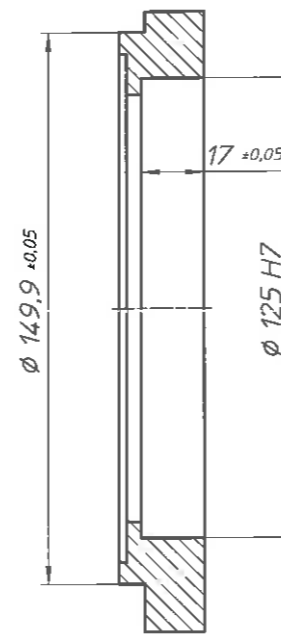
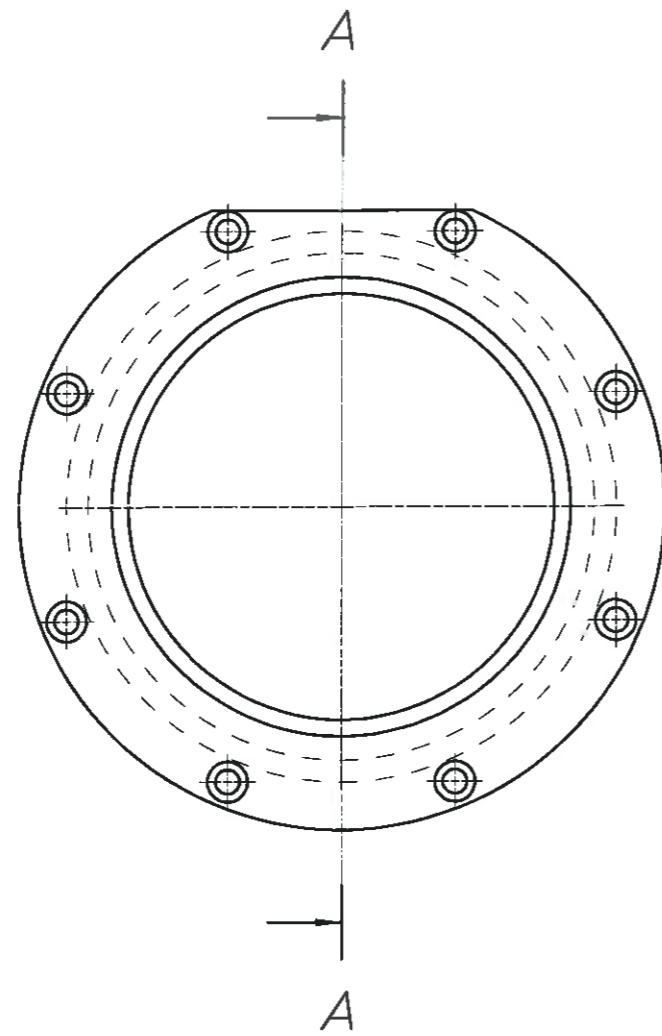

N9/
Mat.: AlMg4.5Mn

Fehlende Maße von 3D Step
bzw. dxf-File entnehmen

CV019626

Bez.	Änderung und Ergänzung		Tag	Name	Gep.
				POR	
	Tag	Name	Mat.:		
Gez.	01.12.2015	por			
Gep.					
Norm gep.					
Maßstab	1:2		Rand-Roller-Coater 4000 x 2300		
Freimaßtoleranzen DIN 7168 fein	Baugruppe: Gummiwalze-gesamt Pos.3, Klemmring		Z.Nr.: 246_210_003 EDV Nr. A0511		
	Ersatz für:				
	Ersetzt durch:		Format A3		