

60 ks rámu = 60ks poz.2 + 60ks poz.3 (zrcadlové provedení) obě pozice na délkou 790 mm, 2x D58 +0.2 mm průchozí + 1x D24 pouze v jedné stěně !!!

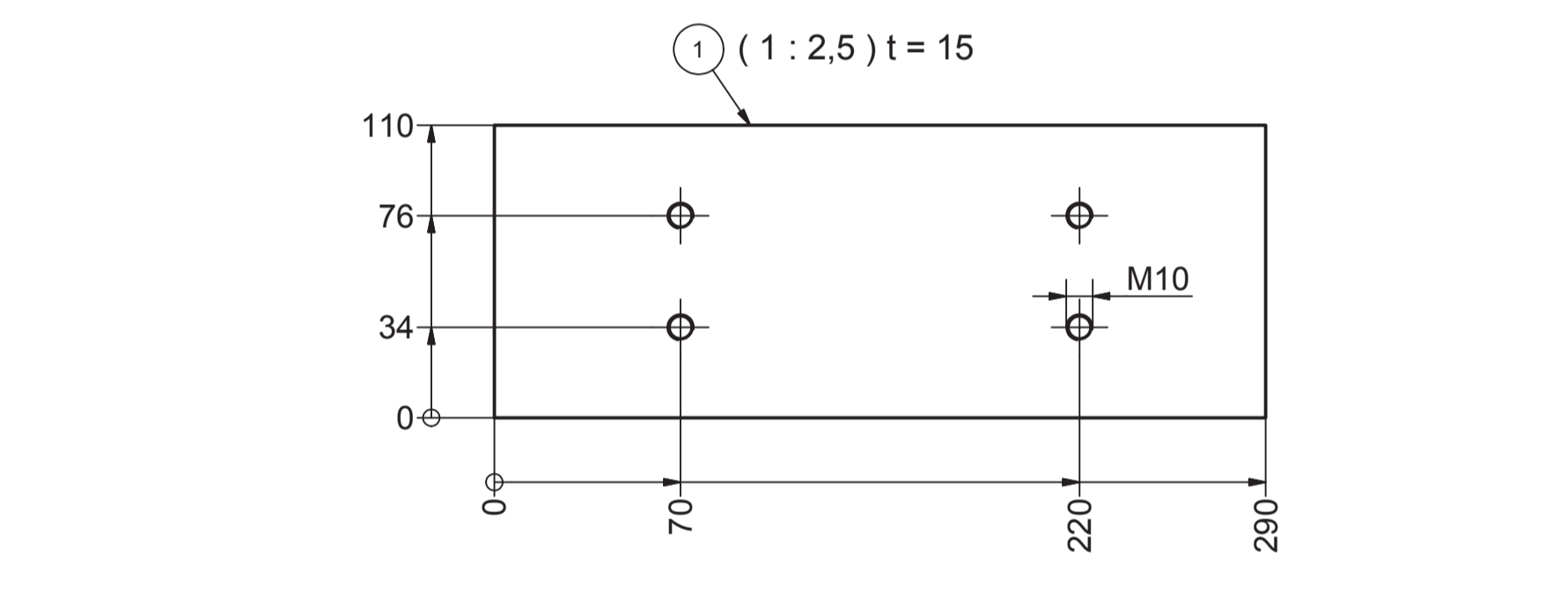
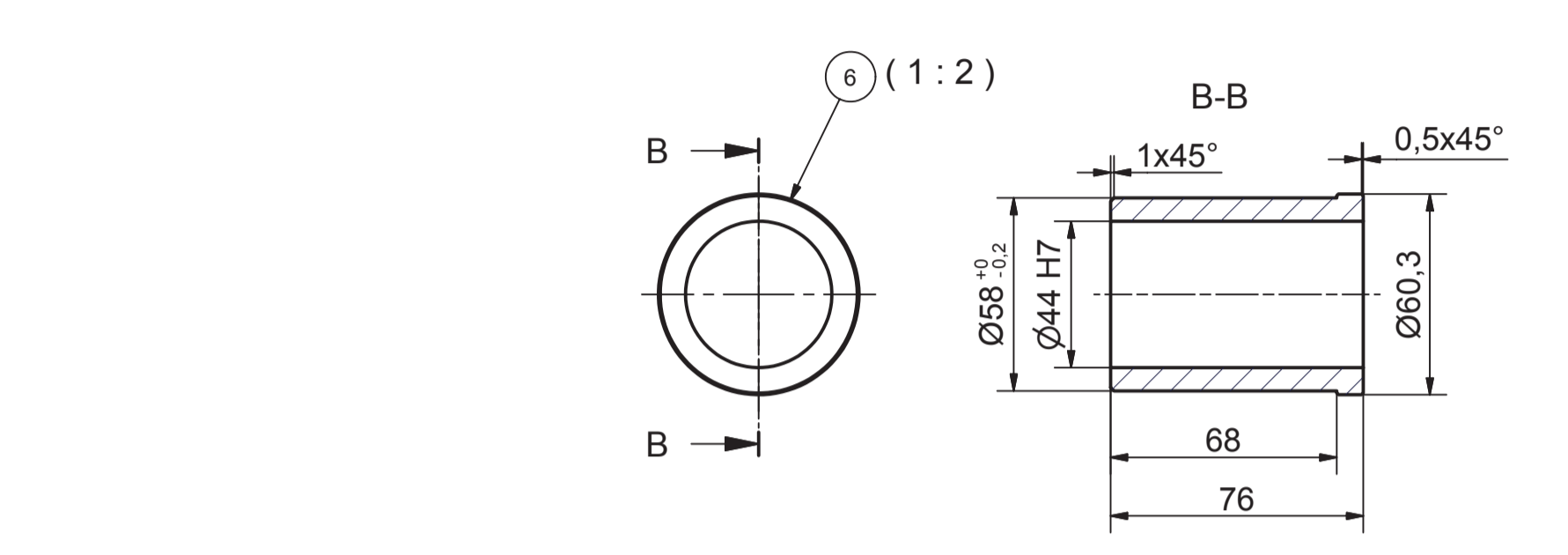
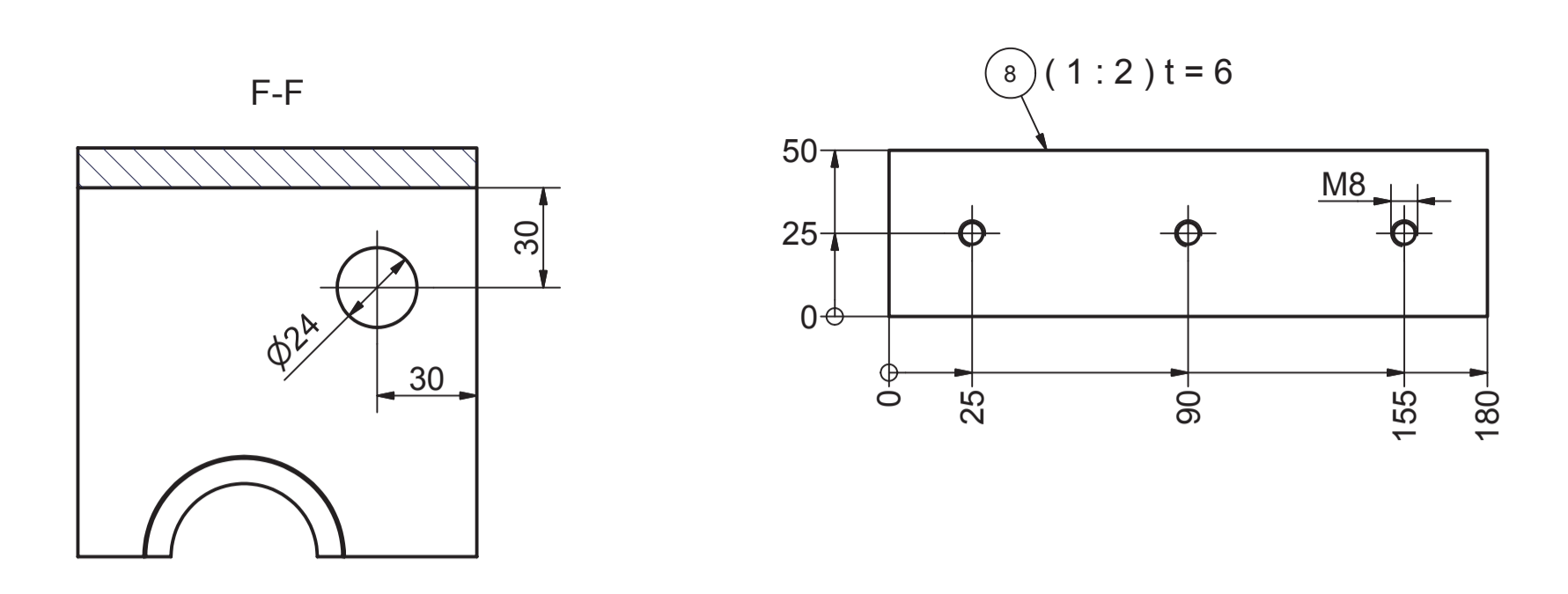

Anderung/ Modifica		Nr.		Anderung		Modifica		Datum/ Data		Nummer Blatt/		Name/ Nome	
1	Pos. 9+10 hinzu	aggiungato	pos. 9+10	19.01.16	8	Wetterney							

ISO 1090-2 EXC2	135 / MAG	a= 0,7 x l (min)	c	BF	Sichtprüfung/ Controllo visuale
Schweißkonstruktion nach Direttiva per le saldature		ISO 5817:2008	ISO 5817:2008	ISO 13962	Prüfverfahren Controllo
Schweißverbindungen ohne Hinweis umlaufend verschweißen					
Saldare intorno se non indicato diversamente					

Pos	Stk	Artikel	Beschreibung	Länge	Breite	Material	Gewicht
10	1	000461	Blech warmgewalzt EN 10029 - lamiera laminata EN 10029 - 4x2000x1000	52	50	1.0037 (S235)	0,1 kg
9	1	000316	Quadratrohr - tubo quadro - 50x 50x 4	47		1.0039 (S235JRH)	0,2 kg
8	1	000095	Flachstahl warmgewalzt EN 10058-piatto laminato EN 10058-50X 6	180		St37	0,4 kg
7	1	000355	Rechteckrohr - tubo rettangolare - 80x 50x 4	200		1.0039 (S235JRH)	1,5 kg
6	4	000283	Rundrohr - tubo tondo - 60,3x12,5	76		1.0577 (S355J2)	0,7 kg
5	1	000109	Flachstahl warmgewalzt EN 10058 - piatto laminato EN 10058 - 100x12	330		1.0038 (S235JR+AR)	3,1 kg
4	1	000030	Flachstahl warmgewalzt EN 10058 - piatto laminato EN 10058 - 120x12	330		1.0038 (S235JR+AR)	3,7 kg
3	1	005771	Rechteckrohr - tubo rettangolare - 120x 60x 6	790		1.0039 (S235JRH)	11,3 kg
2	1	005771	Rechteckrohr - tubo rettangolare - 120x 60x 6	790		1.0039 (S235JRH)	11,3 kg
1	1	005398	Flachstahl warmgewalzt EN 10058 - piatto laminato EN 10058 - 110x15	290		1.0038 (S235JR+AR)	3,7 kg

Angheletti Garzanti	Datum/ Data	Materiali	Import	38,1 kg
08.03.2017	WETAND	1:2	043701	20

Benennung/ Denominazione		Rahmen - telaio	
FEDERARM DRAHTUMLENKUNG		A1	