

8 7 6 5 4 3 2 1

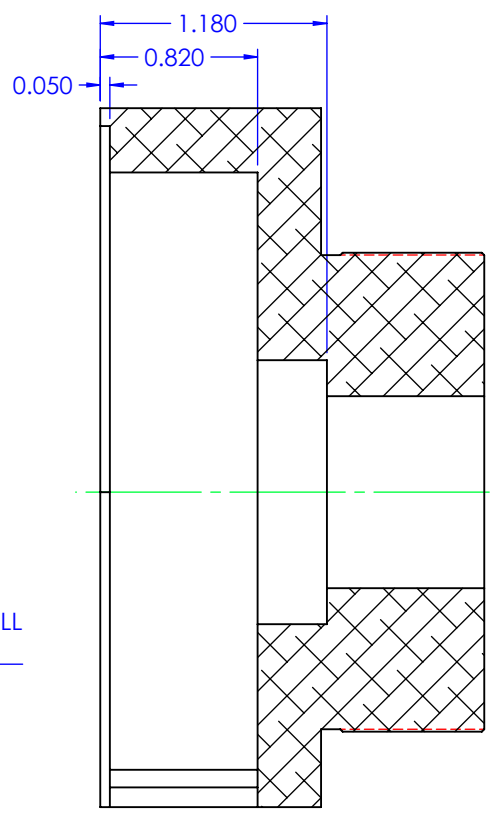

SECTION A-A

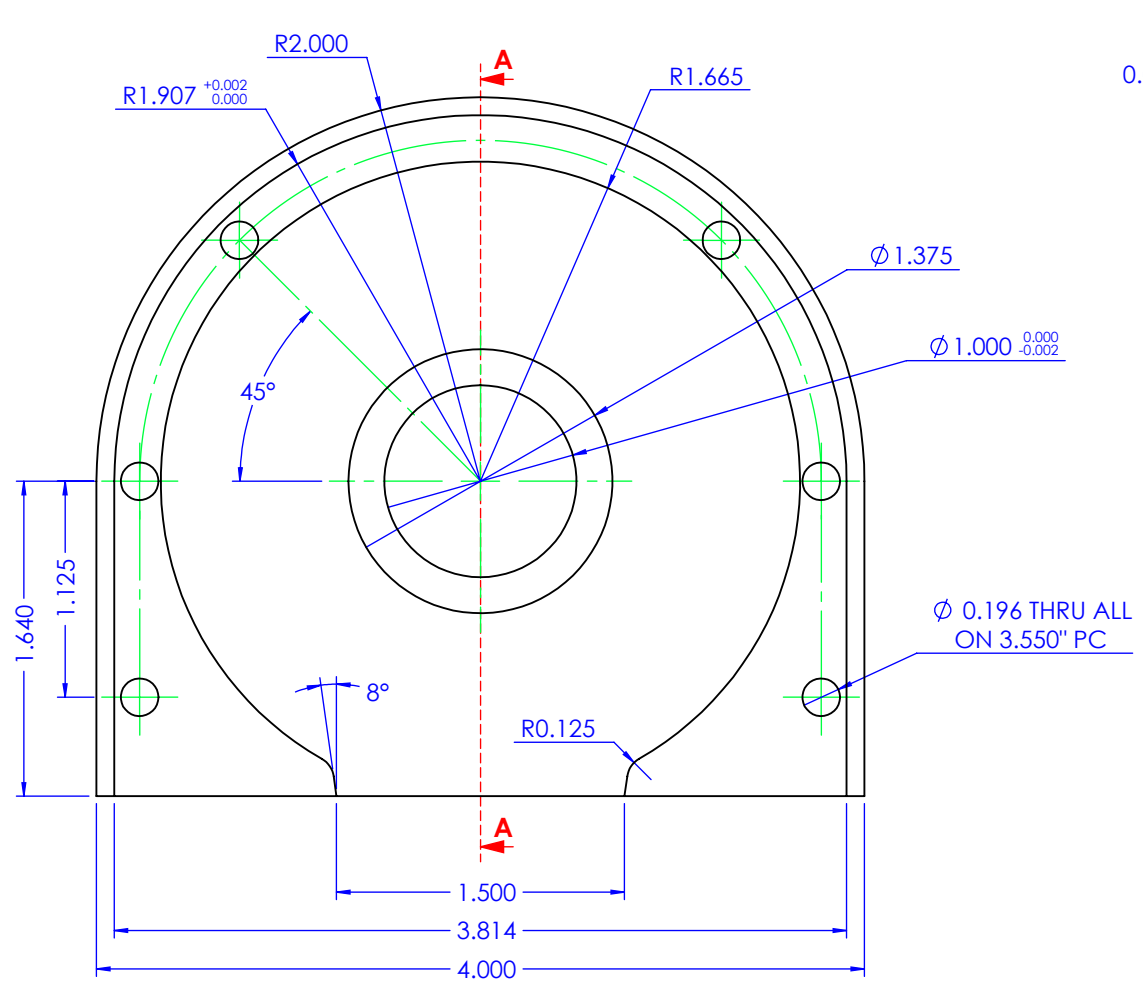
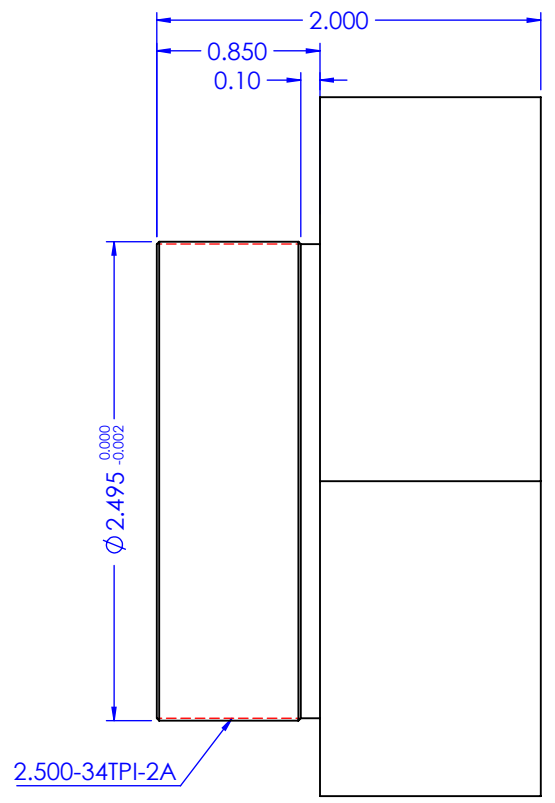
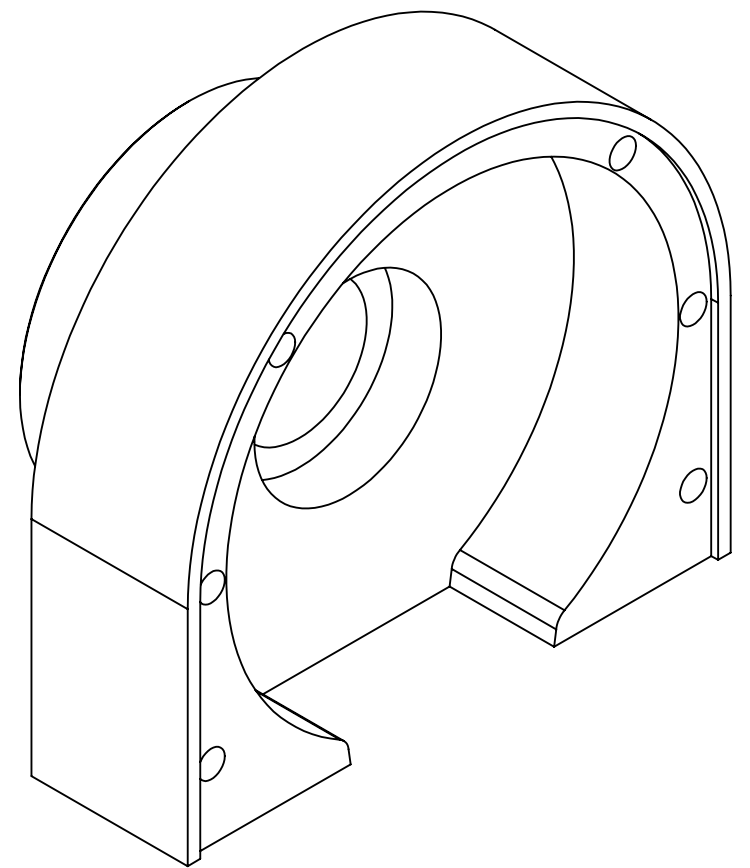

MATERIAL: AL 6061-T6	ASSEMBLY:	DRAWN C. HURLBUT	29/JUN/15	TITLE: COFFEE GRINDER MODE 050 REAR GRINDER HOUSING
UNLESS SPECIFIED: ANGULAR: $\pm .25^\circ$ ONE PLACE DECIMAL $\pm .010$ TWO PLACE DECIMAL $\pm .005$ THREE PLACE DECIMAL $\pm .002$ SURFACE FINISH: MAX 63 RMS REMOVE BURRS, SHARP EDGES CONCENTRICITY .005 T.I.R.		DESIGN		364596 ALBERTA LTD. Ph: (780) 447-5079 DWG. NO. 500-02 REV 3
		APPROVED		
		<small>THE INFORMATION CONTAINED IN THIS DRAWING IS THE PROPRIETARY AND CONFIDENTIAL PROPERTY OF NXT Roasters Inc. ANY REPRODUCTION, DISCLOSURE OR USE FOR ANY PURPOSE OTHER THAN ORIGINALLY INTENDED IS PROHIBITED WITHOUT WRITTEN PERMISSION OF NXT Roasters Inc.</small>		SCALE: 1:1 WEIGHT: 0.99 SHEET 1 OF 1
		DO NOT SCALE DRAWING		

8 7 6 5 4 3 2 1