

A – MISKA – 2ks na otisk

ŘEZ

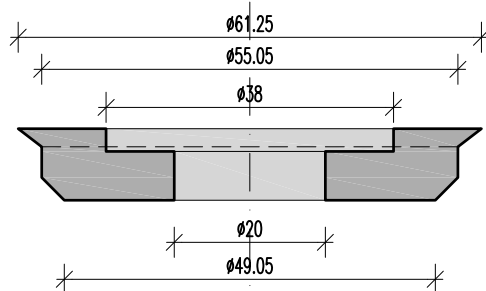

PŮDORYS

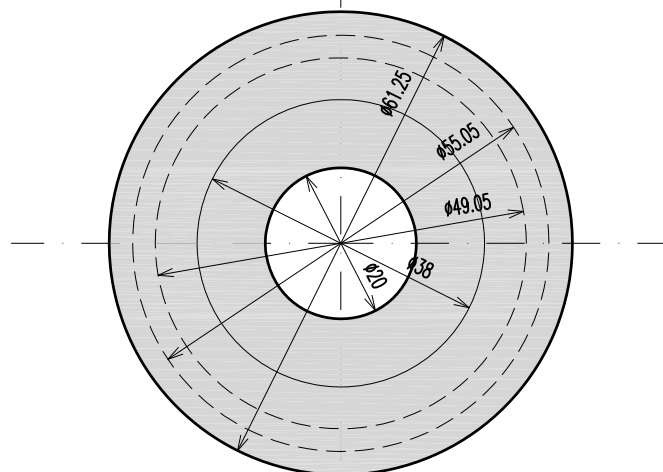

B – PODLOŽKA – 2ks na otisk

ŘEZ

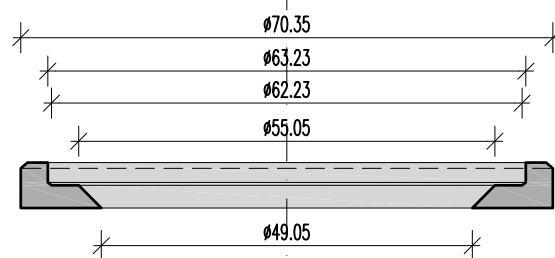

PŮDORYS

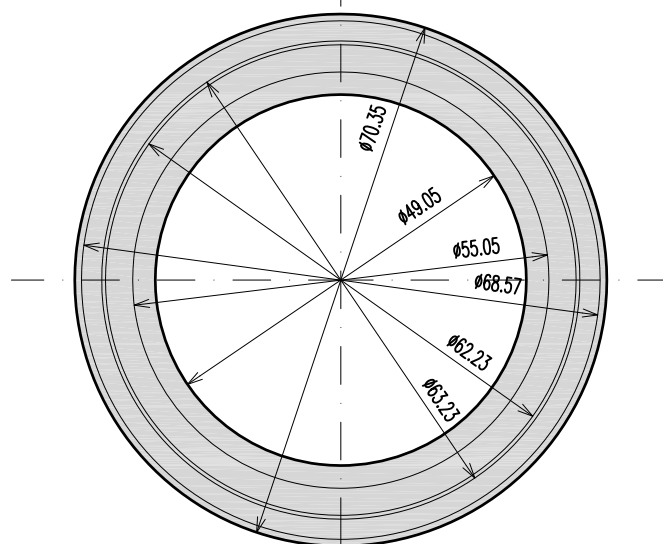

E1 – DOLNÍ ČÁST OTISKU

PŮDORYS

v otisku bude vyfrézován dezén o hloubce segmentů 1.2mm

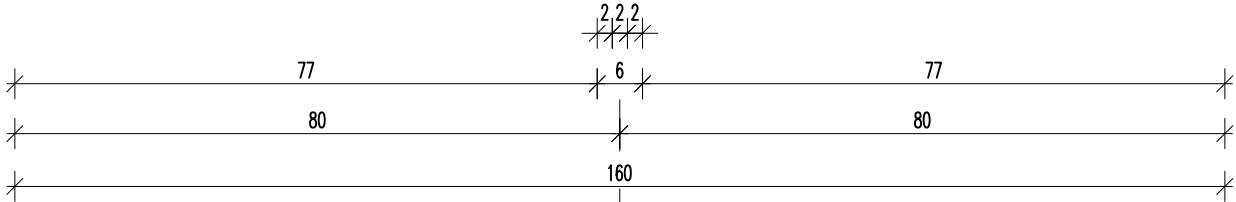
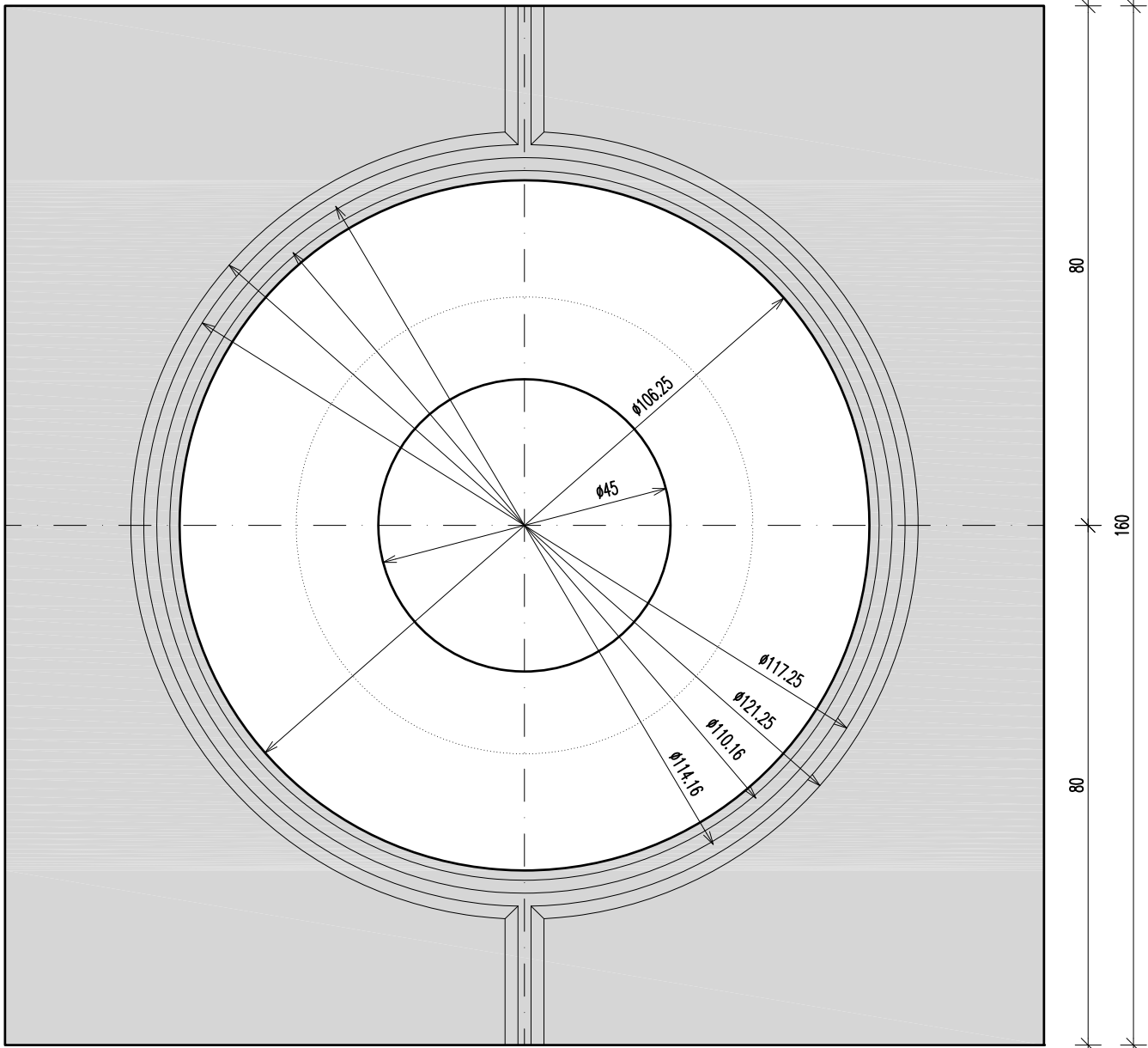

ŘEZ



E2 – HORNÍ ČÁST OTISKU

PŮDORYS

v otisku bude vyfrézován dezén o hloubce segmentů 1.2mm

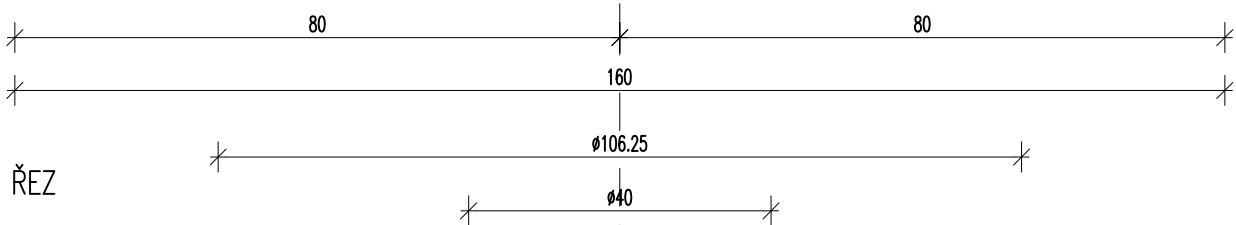
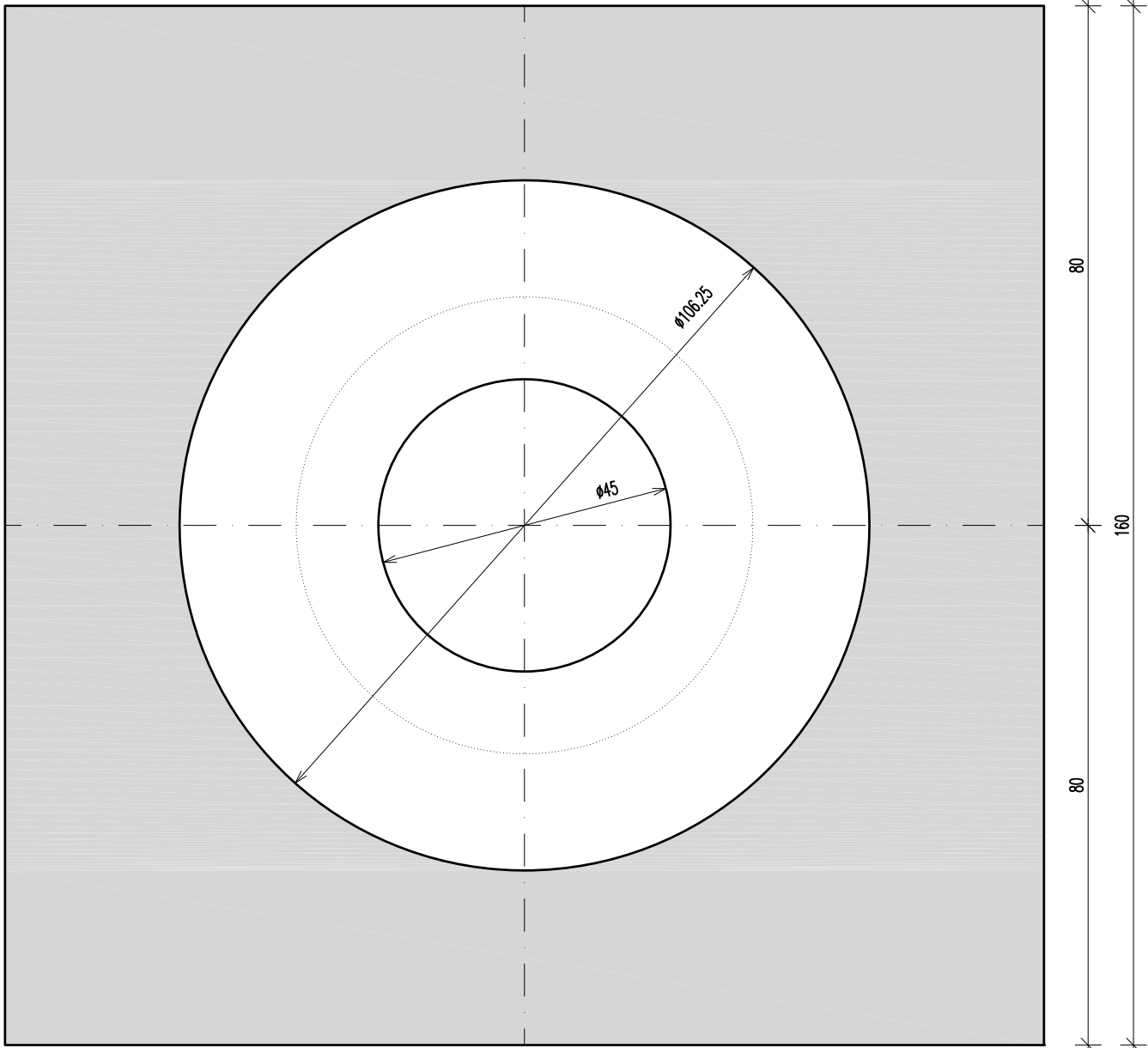

ŘEZ

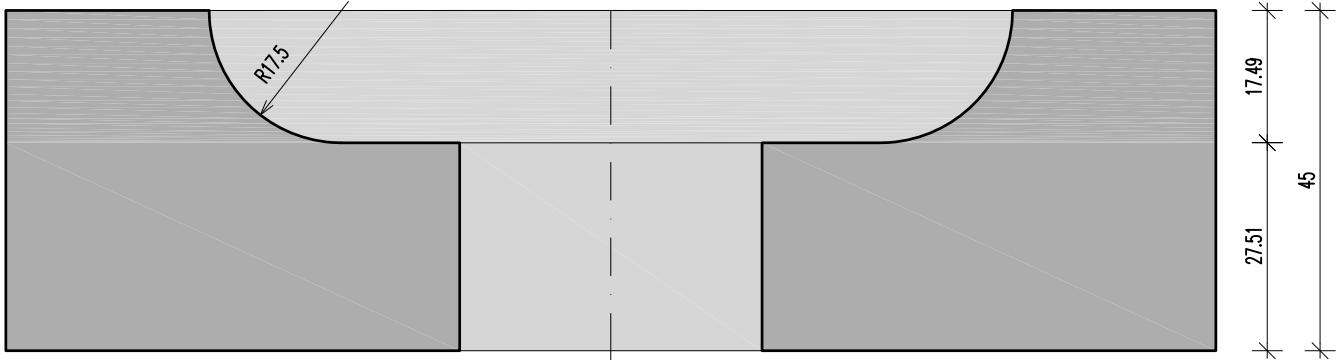

F – SEGMENTY STŘEDOVÉ ČÁSTI:

ŘEZ

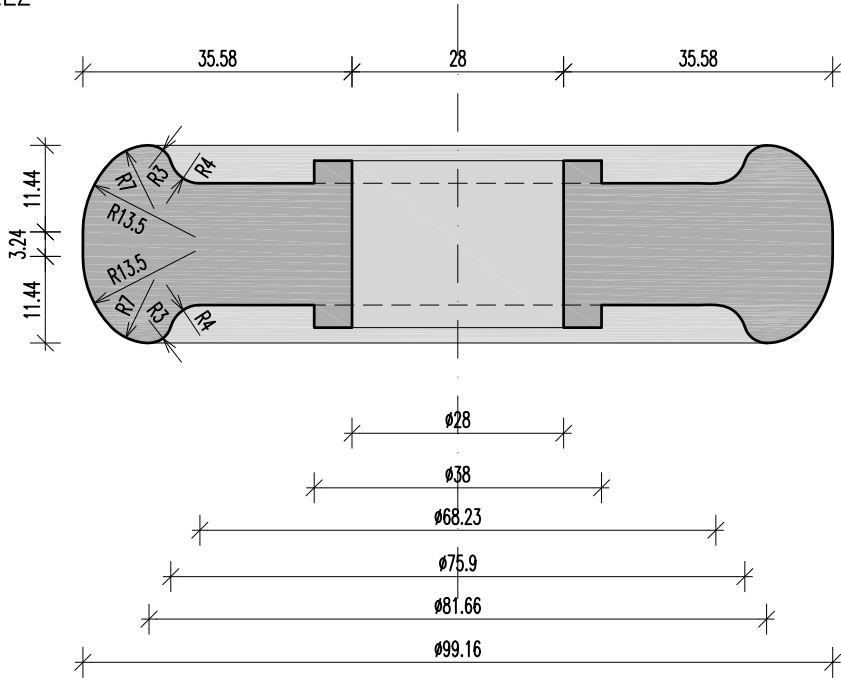

SEGMENT F1 – 5x

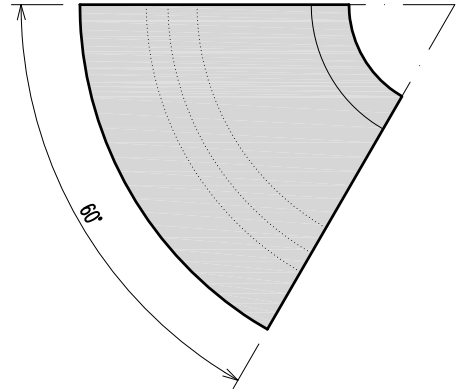

SEGMENT F2 – 1x

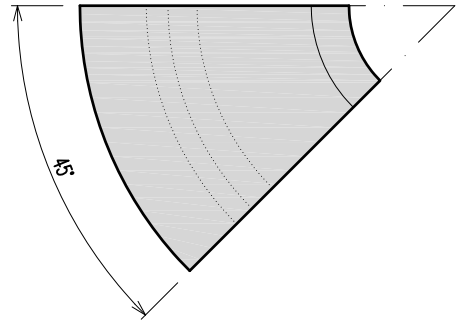

PŮDORYS SESAZENÝCH SEGMENTŮ:

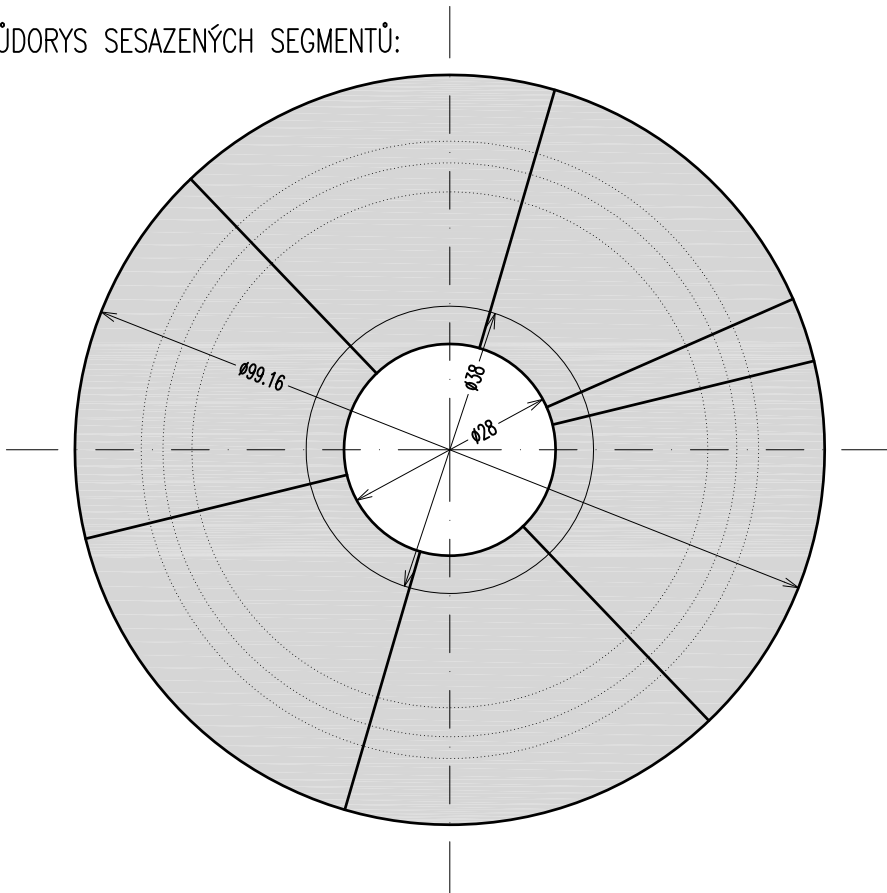

SEGMENT F3 – 1x

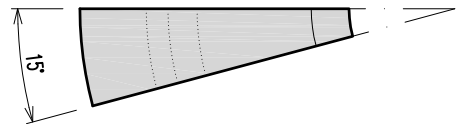

C+D - HŘÍDEL + MATKA

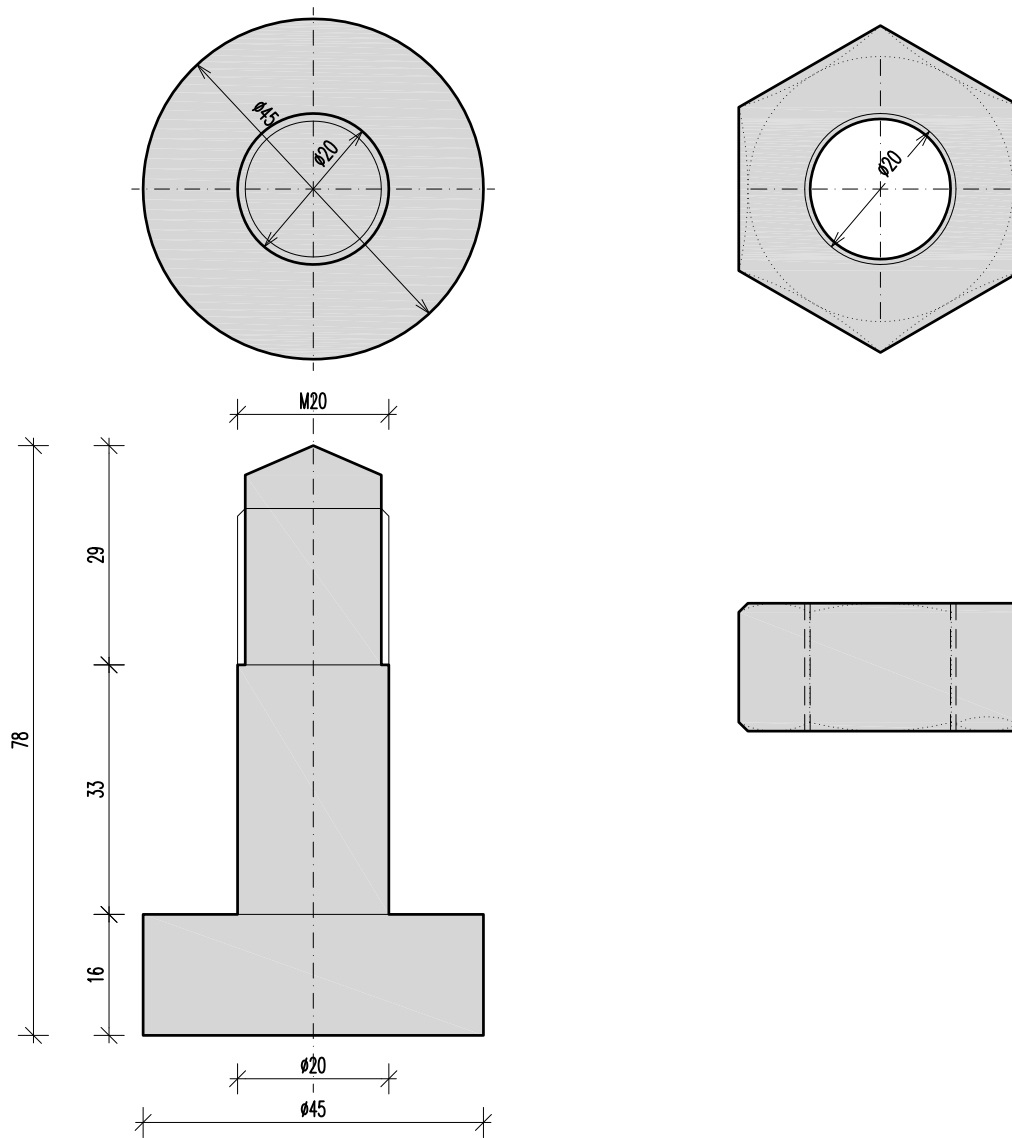

SOUTISK:

